

**I-470 LOT 13A**  
**LEE'S SUMMIT, JACKSON COUNTY, MISSOURI**

**Quist Engineering, Inc**  
 Civil Engineering for Residential &  
 Commercial Site Development  
 824 W. Columbus St.  
 Lee's Summit, Missouri 64063  
 Phone: (816) 550-5575  
 email: rwalquist@quistengineering.com

COPYRIGHT © 2019	
1ST ISSUE	6-20-19
REVISIONS	
△	7-24-19
△	8-7-19
△	8-21-19
SHEET NO.	
<b>C402</b>	
JOB NO.	
E18-337	

**WHEN ARE INLINE DRAINS USED?**

- 2708AG \_\_X
- 2710AG \_\_X
- 2712AG \_\_X
- 2715AG \_\_X
- 2718AG \_\_X
- 2724AG \_\_X
- 2730AG \_\_X

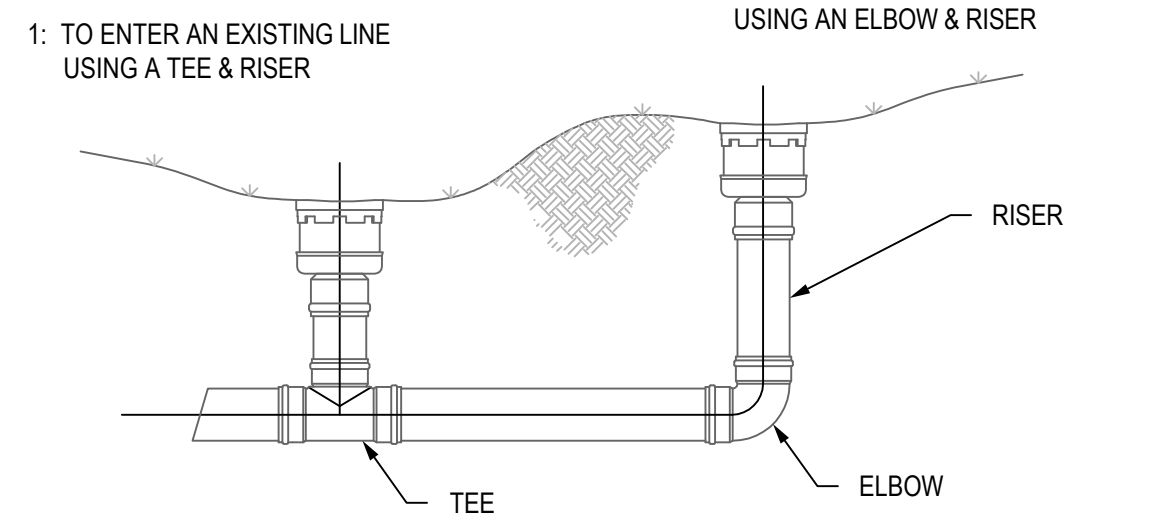

**TYPICAL INSTALLATIONS**

TYPICAL INSTALLATION OF NYLOPLAST DRAIN BASIN AND INLINE DRAIN

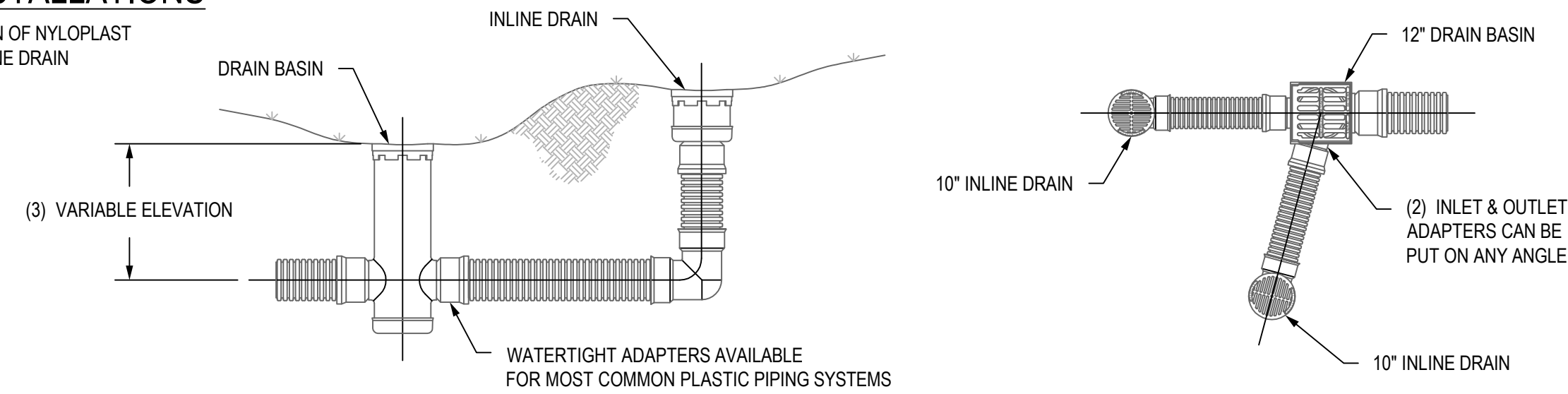

**WHEN ARE DRAIN BASINS USED?**

- 2808AG \_\_X
- 2810AG \_\_X
- 2812AG \_\_X
- 2815AG \_\_X
- 2818AG \_\_X
- 2824AG \_\_X
- 2830AG \_\_X
- 2836AG \_\_X

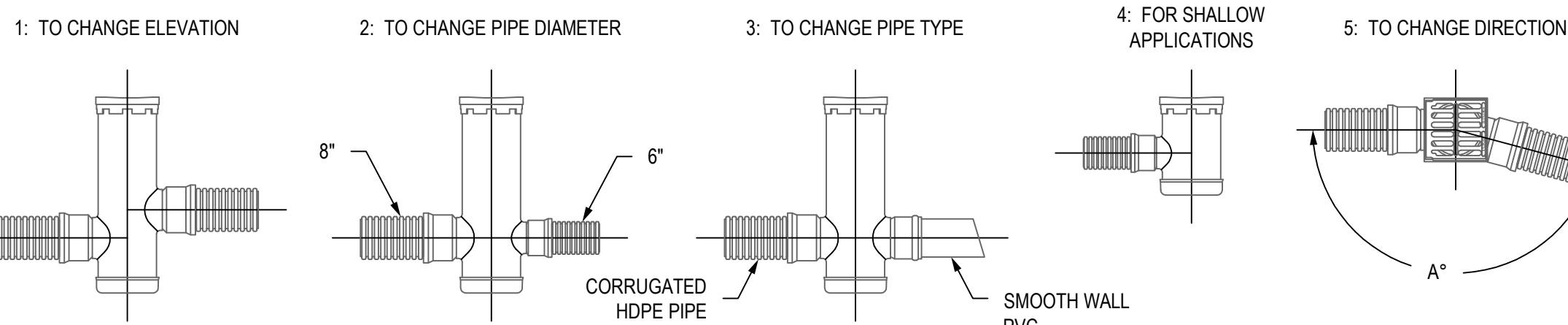

- 1 - STRUCTURES & ADAPTERS AVAILABLE IN SIZES 8" - 36"
- 2 - ADAPTERS CAN BE MOUNTED ON ANY ANGLE 0° TO 360°, TO DETERMINE MINIMUM ANGLE BETWEEN ADAPTERS SEE DRAWING NO. 7001-110-012
- 3 - DRAIN BASIN TO BE CUSTOM MANUFACTURED ACCORDING TO PLAN DETAILS. RISERS ARE NEEDED FOR BASINS OVER 84" DUE TO SHIPPING RESTRICTIONS. SEE DRAWING NO. 7001-110-065
- 4 - REDUCING CONES DOWN TO 30" DIAMETER WILL BE REQUIRED FOR 36" DRAIN BASINS.

**NYLOPLAST 2 FT X 2FT CURB INLET STRUCTURE: 30 \_\_ AGS \_\_ X**

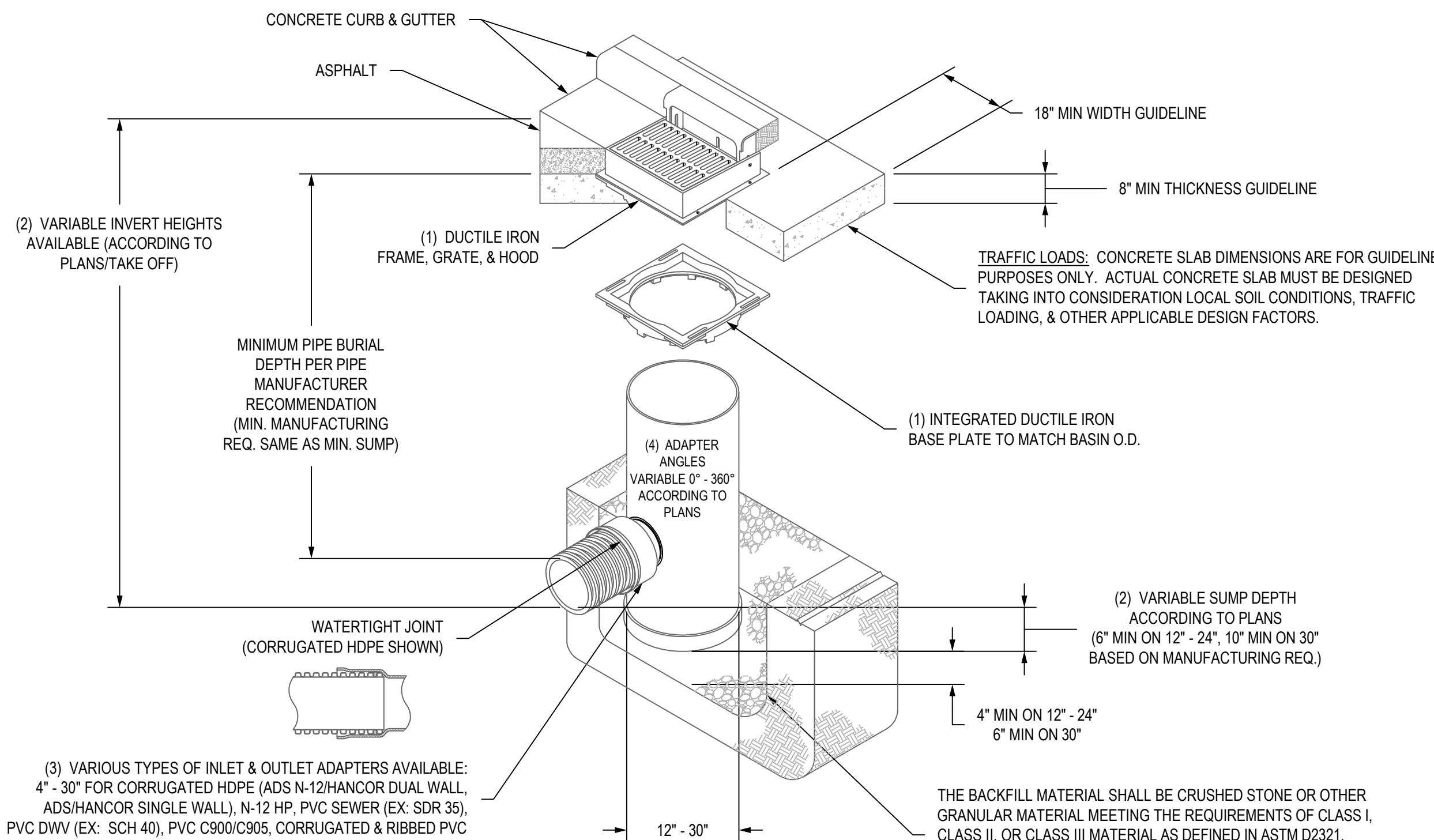

- 1 - 12" - 30" FRAMES, GRATES, HOODS, & BASE PLATES SHALL BE DUCTILE IRON PER ASTM A536 GRADE 70-50-05.
- 2 - DRAIN BASIN TO BE CUSTOM MANUFACTURED ACCORDING TO PLAN DETAILS.
- 3 - DRAINAGE CONNECTION STUB JOINT TIGHTNESS SHALL CONFORM TO ASTM D3212 FOR CORRUGATED HDPE (ADS N-12/HANCOR DUAL WALL, N-12 HP, & PVC SEWER (4" - 24").
- 4 - ADAPTERS CAN BE MOUNTED ON ANY ANGLE 0° TO 360°. TO DETERMINE MINIMUM ANGLE BETWEEN ADAPTERS SEE DRAWING NO. 7001-110-012.
- 5 - ALL CURB INLET GRATE OPTIONS (STANDARD & DIAGONAL) SHALL MEET H-20 LOAD RATING

**NOTE:**  
 INJECTION MOLDED FITTINGS ARE AVAILABLE IN TEES, WYES, REDUCERS, 45° BENDS AND BELLBELL COUPLERS.  
 WATERTIGHT (WT) JOINTS SHOWN. SOIL-TIGHT (ST) FITTINGS ARE ALSO AVAILABLE.

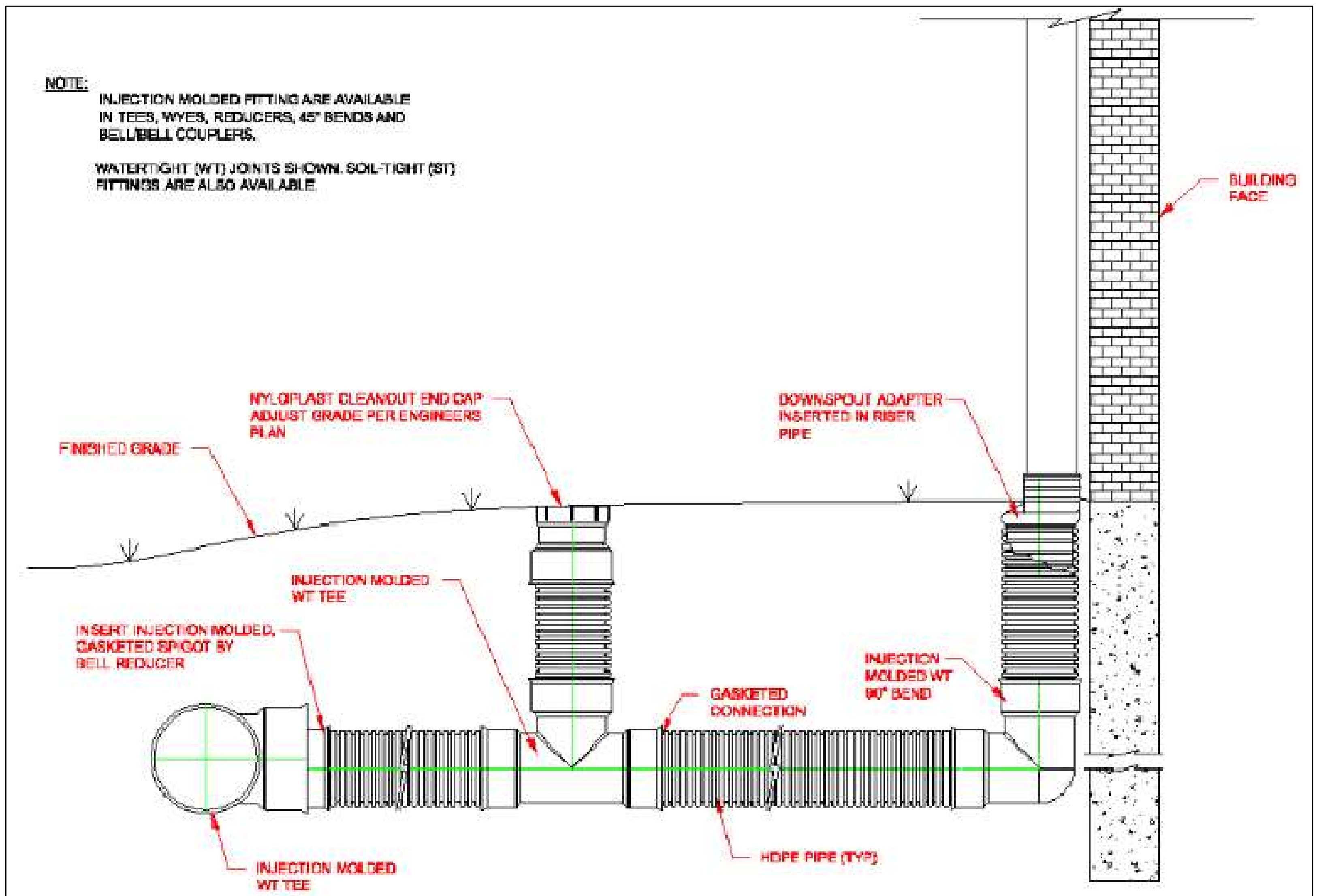

**STORM LINE DETAILS**