

REZNOR®

Model UDAP



Power Vented, Low Static Axial Fan Unit Heaters for Residential and Commercial/Industrial Use

Sizes 30-125

approved for utility applications
such as residential garages
under CSA International Requirement
10.96 - U.S. and CR96-0005 - Canada



CSA 2.6b



ANSI Z83.8b



DESCRIPTION

Reznor® V3 Series Model UDAP gas-fired unit heaters are available in 14 sizes ranging from 30,000 to 400,000 BTUH gas input. Sizes 30-125 are approved for residential application. All sizes are approved for commercial/industrial installations. Model UDAP heaters are designed for 82-83% thermal efficiency and are approved for installation in the United States and Canada by the Canadian Standards Association (CSA).

Reznor V3 Series unit heaters have a refreshing new appearance with a glossy white cabinet finish and less visible hardware. Each size cabinet is easily suspended from either 2 or 4 suspension points. Or, an optional hanger kit for Sizes 30-125 allows for ceiling mounting. The low voltage terminal strip on the outside of the cabinet makes connecting control wiring easy with no panels to remove. The addition of a "G" terminal to the strip, along with the new design of the circuit board, allows for fan only operation (without adding relays). All units have a factory installed gas line nipple to the exterior of the cabinet for easy gas service connection.

The preeminent new internal feature is the T_{CORE}2® heat exchanger and single burner combustion system. Other standard features include a single-stage gas valve, multi-try direct spark ignition with 100% lockout, pressure switch to verify vent flow, resiliently isolated venter motor, venter wheel with improved housing, resiliently isolated axial fan and motor assembly, and a high temperature limit control. Sizes 30-125 also include a flame rollout safety switch. Operation is controlled through an integrated circuit board. The circuit board monitors heater operation and has LED diagnostic indicator lights to identify abnormalities in control functions.

The V3 Series unit heaters are designed to provide all the features you expect in a Reznor heater plus improved efficiency, easier installation, and a new look ~ **both inside and out**. Look for the unique white unit with no visible front and bottom hardware, deep red louvers, black side handle, and angled corner to know you have a genuine Reznor unit by Thomas & Betts.

STANDARD FEATURES

- Sizes 30-125 certified for residential heating application
- Sizes 30-400 certified for commercial/industrial heating application
- 82-83% Thermal efficient ~ **TOP in its class!**
- 50-60°F Rise range
- T_{CORE}2® titanium stabilized aluminized steel heat exchanger
- Patented** T_{CORE}2® single burner combustion system including a one-piece burner assembly
- 115/1/60 Supply voltage
- 115 Volt open fan motor with internal overload protection
- Transformer for 24-volt controls
- Integrated circuit board with diagnostic indicator lights
- Multi-try direct spark ignition with 100% lockout
- Fan relay (included on the circuit board)
- Single-stage natural gas valve (field adjustable for operation to 9,000 ft. elevation)
- Vibration/noise isolated fan and venter motors ~ **designed for low noise operation**
- 2-pt **and** 4-pt Suspension ~ **standard on all sizes**
- External terminal strip for 24-volt wiring
- External gas connection
- Full fan guard ~ **engineered for safety**
- Improved cabinet design with less visible hardware and a **NEW** Reznor appearance

OPTIONAL FEATURES - FACTORY INSTALLED

- Single-stage, propane gas valve (field adjustable for operation to 9,000 ft. elevation)
- Two-stage natural gas or propane gas valve - Sizes 60-400
- 409 or 316 Stainless steel heat exchangers
- 208 or 230 Single phase voltage
- Totally enclosed fan motor (Sizes 30-250, 115V only)
- Common venting with other gravity vented Category I appliance(s) (Sizes 30-100)

* U.S. Patent No. 6,889,686

**OPTIONAL FEATURES -
FIELD INSTALLED**

- Vent cap
- Thermostat
- Thermostat guard with locking cover
- Vertical louvers ~ *new design*
- Downturn nozzle kits ~ *new design*
- Gas conversion kits (natural and propane)
- Master/Slave controls for zoning up to six units
- Ceiling suspension kit - Sizes 30-125
- Hanger kits for 1" pipe
- Stepdown transformer (for 230/3 and 460/3 supply voltage)
- Manual shutoff valves

TECHNICAL DATA

Model UDAP

Size		30	45	60	75	100	125	150	175	200	225	250	300	350	400
Input Heating Capacity	BTUH	30,000	45,000	60,000	75,000	105,000	120,000	150,000	175,000	200,000	225,000	250,000	300,000	350,000	400,000
	kW/h	8.8	13.2	17.6	22.0	30.8	35.2	43.9	51.2	58.6	65.9	73.2	87.8	102.5	117.1
Thermal Efficiency (%)		82	83	83	83	83	83	83	83	83	83	83	83	83	83
Output Heating Capacity ^A	BTUH	24,600	37,350	49,800	62,250	87,150	99,600	124,500	145,250	166,000	186,750	207,500	249,000	290,500	332,000
	kW/h	7.2	11.0	14.6	18.3	25.6	29.2	36.4	42.5	48.6	54.7	60.8	72.9	85.1	97.2
Gas Connection (inches) ^B	Natural	1/2	1/2	1/2	1/2	1/2	1/2	1/2	1/2	1/2	3/4	3/4	3/4	3/4	3/4
	Propane	1/2	1/2	1/2	1/2	1/2	1/2	1/2	1/2	1/2	3/4	3/4	3/4	3/4	3/4
Vent Connection Size ^C (inches diameter)		4	4	4	4	4	4	5	5	5	5	5	6	6	6
Control Amps (24 volt)		1.0	1.0	1.0	1.0	1.0	1.0	1.0	1.0	1.0	1.0	1.0	1.0	1.0	1.0
Full Load Amps (115 volt)		1.9	2.4	2.4	3.3	3.9	5.1	3.8	3.8	4.6	7.5	7.5	11.0	11.0	11.0
Maximum Over Current Protection (115V) ^D		15	15	15	15	15	15	15	15	15	15	15	20	20	20
Normal Power Consumption (watts)		109	155	155	217	276	354	392	392	491	747	747	1086	1086	1086
Discharge Air Temperature Rise (°F)		50	55	60	60	60	60	60	60	60	60	60	60	60	60
Air Volume	CFM	456	629	769	961	1345	1537	1921	2242	2562	2882	3202	3843	4483	5123
	M ³ /minute	12.9	17.8	21.8	27.5	36.7	45.9	54.4	63.5	72.5	81.6	90.7	108.8	126.9	145.1
Discharge Air Opening Area	ft ²	0.96	0.96	1.25	1.25	2.01	2.01	2.56	2.56	2.56	3.51	3.51	4.79	4.79	4.79
	M ²	0.09	0.09	0.12	0.12	0.19	0.19	0.24	0.24	0.24	0.33	0.33	0.45	0.45	0.45
Output Velocity	FPM	475	656	616	770	668	763	752	877	1003	820	911	802	936	1069
	M/minute	145	200	188	238	196	245	229	267	306	250	278	244	285	326
Fan Motor HP ^E	Open	0.02	0.03	0.03	0.06	1/30	1/20	1/6	1/6	1/6	1/4	1/4	1/2	1/2	1/2
	Enclosed	0.06	0.06	0.06	0.06	1/4	1/4	1/4	1/4	1/4	1/4	1/4	1/2	1/2	1/2
Fan Motor RPM		1550	1550	1550	1550	1050	1050	1050	1050	1050	1050	1050	1050	1050	1050
Fan Diameter (inches)		10	10	12	12	16	16	18	18	18	20	20	24	24	24
Sound Level	dBA @ 15 ft	40	40	40	49	54	55	51	52	53	56	56	59	61	62
Approximate Net Weight	lbs	54	59	67	72	96	101	172	187	187	203	215	269	294	306
	kg	24	27	30	33	44	46	78	85	85	92	98	122	133	139
Approximate Ship Weight	lbs	61	66	74	79	118	123	204	219	219	245	257	321	346	358
	kg	27	30	33	36	54	56	93	100	100	111	117	146	157	163

^A CSA rating for altitudes to 2000 ft.

^B Size shown is for gas connection to a single stage gas valve, not supply line size.

^C Smaller or larger vent pipe diameters may be allowed; refer to the Venting Installation Manual, Form I-V-PV. If vent diameter is different from vent connection, reducer/enlargers will be field-required.

^D MODP = 2.25 x (largest motor FLA) + smallest motor FLA. Answer is rounded to the nearest commercially available circuit breaker.

^E All other information in this table is based on a heater equipped with a standard 115 volt open fan motor.

DIMENSIONS

Model UDAP

±1/16" (2mm)

Size	A	B	C	D	E	F	G	H	J	K	M	N	P	Q	R
30, 45	12 1/8	25 5/8	10	13 13/16	26	21 9/16	5 3/16	6 1/2	2 11/16	3 7/8	17 3/8	11/16	4 5/16	13	9 9/16
60	15 1/8	25 5/8	13	13 13/16	27	21 9/16	7 7/8	6 1/2	5 1/2	3 7/8	17 3/8	11/16	4 5/16	13	10 1/2
75	15 1/8	25 5/8	13	13 13/16	27 5/8	21 9/16	7 7/8	6 1/2	5 1/2	3 7/8	17 3/8	11/16	4 5/16	13	10 1/2
100	23 1/8	25 5/8	21	13 13/16	28 5/8	21 9/16	14 1/2	6 1/2	8 3/4	3 7/8	17 3/8	11/16	4 5/16	13	10 1/2
125	23 1/8	25 5/8	21	13 13/16	29 3/8	21 9/16	14 1/2	6 1/2	8 3/4	3 7/8	17 3/8	11/16	4 5/16	13	10 1/2
150, 175, 200	20 1/8	38 3/16	16	2 3	42	35 3/8	8 1/2	8 1/4	5 7/16	6 1/2	25 11/16	1 3/8	8 3/16	22 3/16	16 3/8
225, 250	26 1/8	38 3/16	22	23	42	35 3/8	13 1/16	8 13/16	9	6 1/2	25 11/16	1 3/8	8 3/16	22 3/16	15 5/8
300, 350, 400	34 1/8	4 1	30	23	42	35 3/8	17 1/16	9	11 13/16	7 5/16	27 11/16	1 3/8	8 3/16	22 3/16	16 3/16
Size	A	B	C	D	E	F	G	H	J	K	M	N	P	Q	R
30, 45	(308)	(651)	(254)	(351)	(660)	(548)	(132)	(165)	(68)	(98)	(441)	(17)	(110)	(330)	(243)
60	(384)	(651)	(330)	(351)	(686)	(548)	(200)	(165)	(140)	(98)	(441)	(17)	(110)	(330)	(267)
75	(384)	(651)	(330)	(351)	(702)	(548)	(200)	(165)	(140)	(98)	(441)	(17)	(110)	(330)	(267)
100	(587)	(651)	(533)	(351)	(727)	(548)	(368)	(165)	(222)	(98)	(441)	(17)	(110)	(330)	(267)
125	(587)	(651)	(533)	(351)	(746)	(548)	(368)	(165)	(222)	(98)	(441)	(17)	(110)	(330)	(267)
150, 175, 200	(511)	(970)	(406)	(584)	(1,067)	(899)	(216)	(210)	(138)	(165)	(652)	(35)	(208)	(564)	(416)
225, 250	(664)	(970)	(559)	(584)	(1,067)	(899)	(332)	(224)	(229)	(165)	(652)	(35)	(208)	(564)	(397)
300, 350, 400	(867)	(1,041)	(762)	(584)	(1,067)	(899)	(433)	(229)	(300)	(186)	(703)	(35)	(208)	(564)	(411)

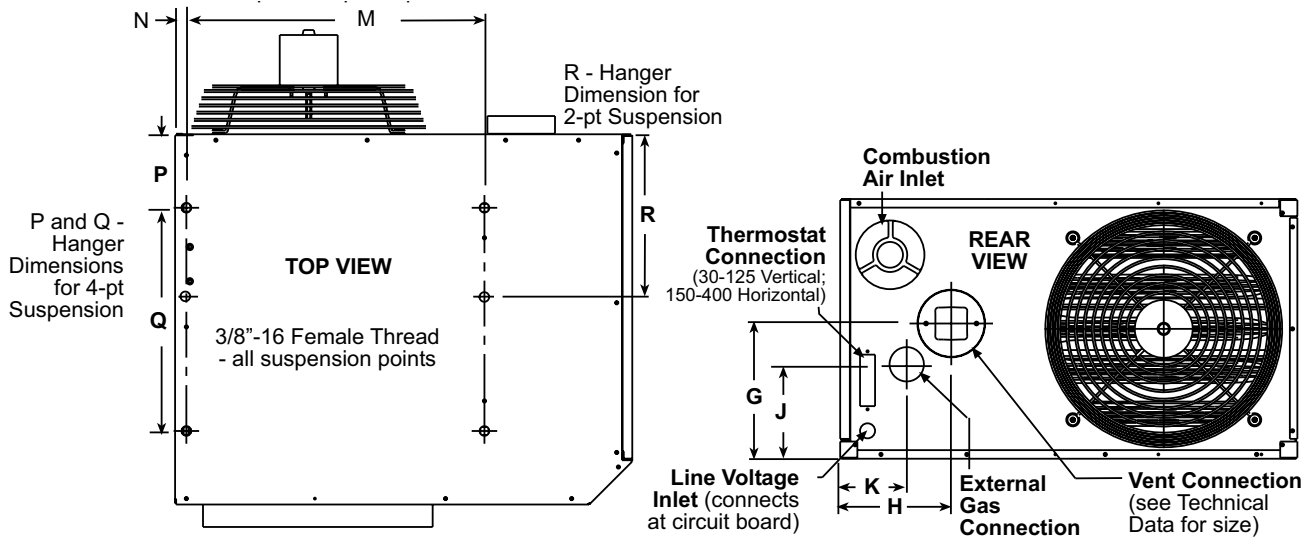

CLEARANCES FROM COMBUSTIBLES

Size	Top		Flue Connector		Access Panel		Non-Access Side		Bottom*		Rear	
	inches	mm	inches	mm	inches	mm	inches	mm	inches	mm	inches	mm
30-125	1	25	6	152	18	457	1	25	1	25	18	457
150-400	4	102	6	152	18	457	2	51	1	25	18	457

*Suspend the heater so that the bottom is a minimum of 5' (1.5M) above the floor.