

FINAL PLAT  
**LEE'S SUMMIT SURGICAL  
 CENTER – LOT 1**  
 LOTS 15 THRU 20, I-470 BUSINESS AND TECHNOLOGY  
 CENTER, SECTION 20, TOWNSHIP 48, RANGE 31, CITY  
 OF LEE'S SUMMIT, JACKSON COUNTY, MISSOURI

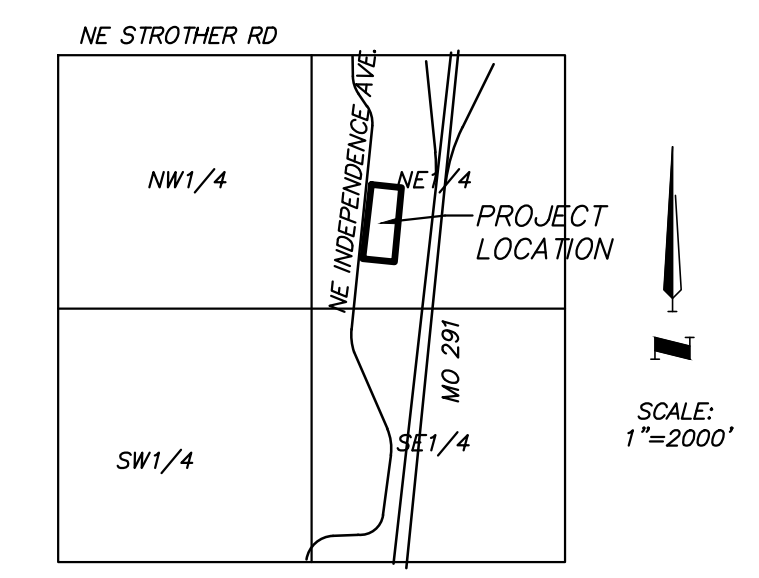

VICINITY MAP  
 SEC. 20-48-31

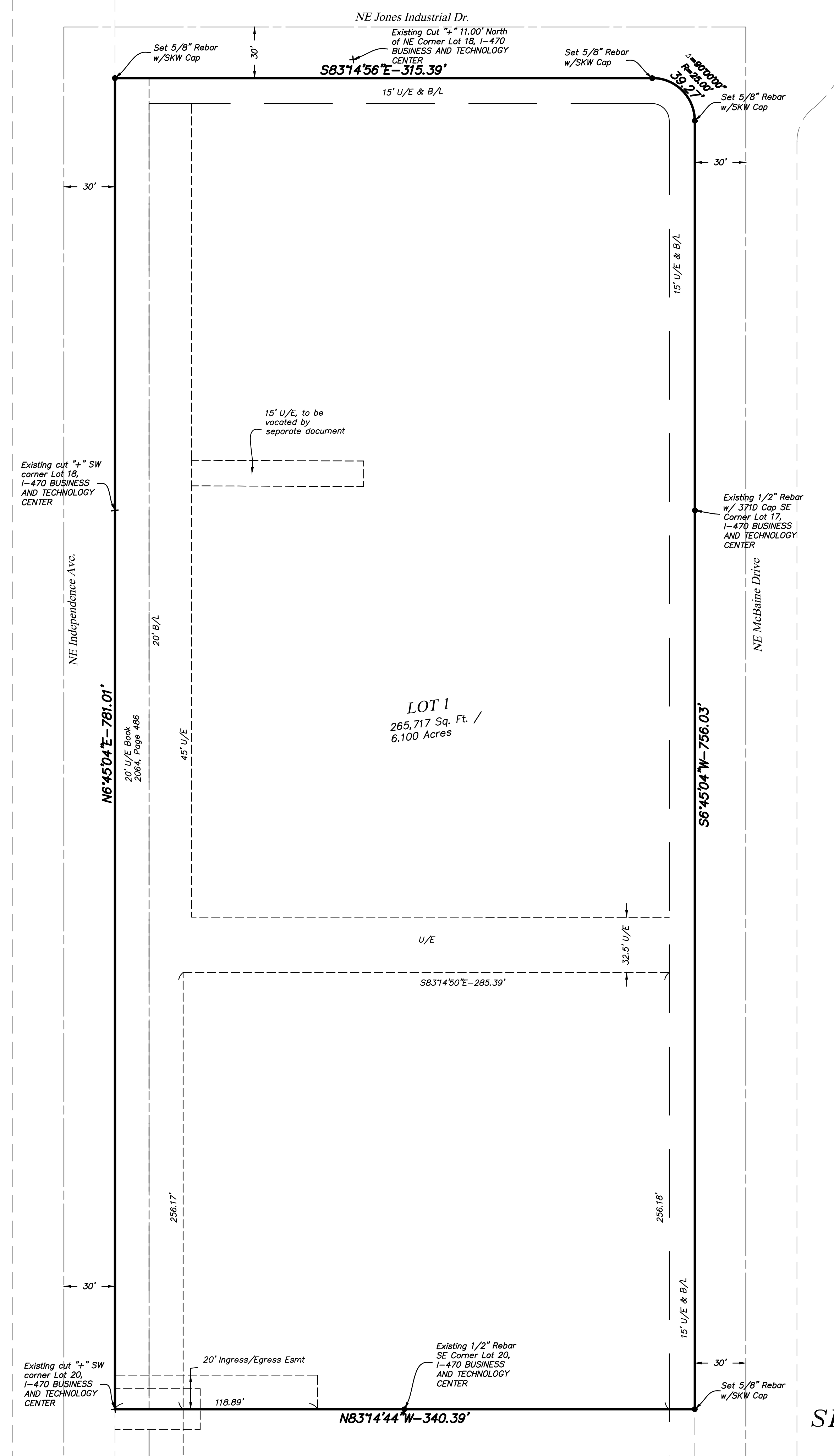
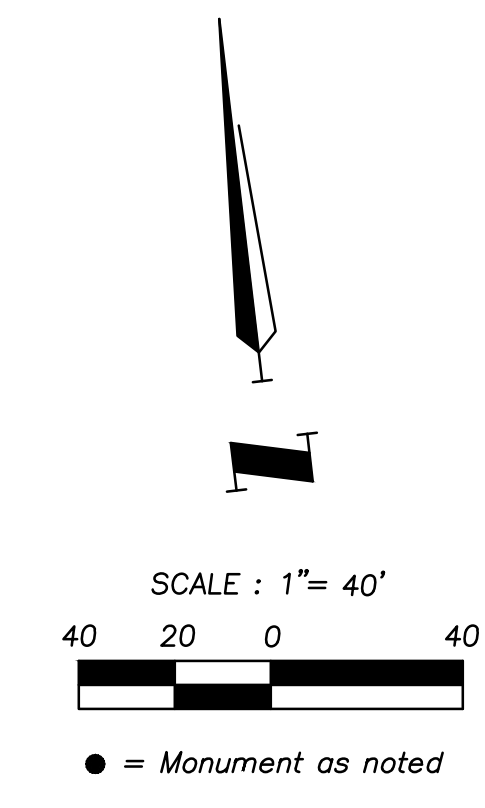

**ZONING NOTE:**  
 The subject property is zone "PMIX – Planned Mixed Use"

**FLOOD ZONE NOTE:**  
 this property lies within FLOOD ZONE X, defined as areas determined to be outside the 0.2% annual chance floodplain, Agency's National Flood Insurance Program for Lee's Summit, Jackson County, Missouri, Map Number 29095C0430G, dated January 20, 2017.

**LEGAL DESCRIPTION:**  
 All of Lots 15 thru 20, I-470 BUSINESS AND TECHNOLOGY CENTER, a subdivision in the City of Lee's Summit, Jackson County, Missouri.  
 The above described tract of land contains 265,717 square feet, or 6.100 acres, more or less.

**DEDICATIONS:**  
 The undersigned proprietor of the above described tract of land has caused the same to be subdivided in the manner as shown on the accompanying plat, which subdivision shall hereafter be known as "LEE'S SUMMIT SURGICAL CENTER – LOT 1".

**Easements:** An easement or license is hereby granted to the City of Lee's Summit, Missouri, to locate, construct and maintain, or to authorize the location, construction and maintenance of poles, wires, anchors, conduits, and/or structures for water, gas, sanitary sewer, storm sewer, surface drainage channel, electricity, telephone, cable television, or any other necessary public utility or services, any or all of them, upon, over, or under those areas outlined or designated upon this plat as "Utility Easements" (U.E.) or within any street or thoroughfare dedicated to public use on this plat. Grantor, on behalf of himself, his heirs, his assigns and successors in interest, hereby waives, to the fullest extent allowed by law, including, without limitation, Section 527.188, RSMo. (2006), any right to request restoration of rights previously transferred and vacation of the easement herein granted.

A permanent easement is hereby granted for vehicular access onto and through the area designated as "Ingress/Egress Easement".  
**Building Lines:** Building lines or setback lines are hereby established as shown on the accompanying plat and no building or portion thereof shall be constructed between this line and the street right of way line.

LSMOB Owner, LLC on behalf of themselves, their heirs, their assigns and successors in interest, hereby waives, to the fullest extent allowed by law, including, without limitation, Section 527.188 RSMo. (2006) any right to request restoration of rights previously transferred and vacation of the easements herein granted.

IN TESTIMONY WHEREOF, the undersigned proprietor has hereunto subscribed its hand.

LSMOB Owner, LLC

County of \_\_\_\_\_ )  
 State of \_\_\_\_\_ ) SS

BE IT REMEMBERED that on this \_\_\_\_\_ day of \_\_\_\_\_, 20\_\_\_\_, before me, the undersigned, a Notary Public in and for said County and State aforesaid, came \_\_\_\_\_ of LSMOB Owner, LLC, to me personally known to be the same person who executed the within instrument and duly acknowledged the same to be their free act and deed.

IN WITNESS WHEREOF, I have hereunto set my hand and affixed my official seal the day and year last above written.

My Appointment Expires: \_\_\_\_\_

This is to certify that the within plat of "LEE'S SUMMIT SURGICAL CENTER – LOT 1" was submitted to and duly approved by the Mayor and City Council of the City of Lee's Summit, Missouri, this \_\_\_\_\_ day of \_\_\_\_\_, 20\_\_\_\_ by Ordinance No. \_\_\_\_\_ "Date

ATTEST: \_\_\_\_\_  
 Denise R. Chisum, MMC, City Clerk Date

George M. Binger III, PE, City Engineer Date  
 Robert G. McKay, AICP, Director of Planning and Special Projects

Approved by the Jackson County, Missouri Assessors Office this \_\_\_\_ day of \_\_\_\_\_ 20 \_\_\_\_.

\_\_\_\_\_  
 Date

**SURVEYOR'S CERTIFICATION:** I hereby certify that the plat titled "LEE'S SUMMIT SURGICAL CENTER – LOT 1", a subdivision, is based on an actual field survey made by me or under my direct supervision and that said survey meets or exceeds the current "Minimum Standards for Property Surveys" as established by the Department of Natural Resources, Division of Geology and Land Survey of the State of Missouri and the Missouri Standards for Property Boundary Surveys established by the Missouri Board for Architects, Professional Engineers and Land Surveyors. I further state that I have complied with the statutes, ordinances and regulations governing the practice of surveying and platting of subdivisions to the best of my professional knowledge and belief. Field work was completed on August 23, 2017.

**SHAFER, KLINE & WARREN, INC.**  
**ENGINEERS ~ SURVEYORS**  
 11250 CORPORATE AVENUE, LENEXA, KANSAS 66219  
 PHONE (913) 888-7800 FAX (913) 888-7868

BY: \_\_\_\_\_  
 ROBERT C. SANDLIN MO PLS-2016000169