

McCLURE ENGINEERING CO.
building strong communities.
1901 Pennsylvania Drive
Columbia, MO 65202
P 573-814-1568
F 573-814-1128
MISSOURI CERTIFICATE OF AUTHORITY
NO. E-2006023253
EXPIRES: DECEMBER 31, 2016

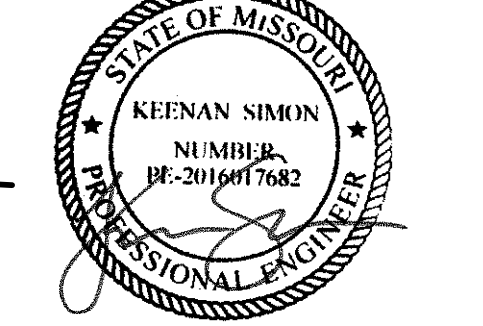

09/15/2016
Keenan Simon
MO-2016017682
Expires: 12-31-2016

A NEW APARTMENT COMMUNITY AT:
SUMMIT SQUARE
701 NW WARD RD.
LEE'S SUMMIT, MISSOURI

DRAWING RELEASE LOG

03.04.2016	- PDP SUBMITTAL
06.09.2016	- FDP SUBMITTAL
07.01.2016	- 80% PROGRESS SET
07.15.2016	- PERMIT SUBMITTAL
08.05.2016	- BID SET
09.15.2016	- BID SET

REVISIONS

NO.	DATE	DESCRIPTION

DATE
09/15/2016
JOB No.
80816033
DRAWN BY:
GRK
SHEET No.

DRAINAGE AREA
C003

Note:
See Stormwater Report for Drainage Area Calculations and Storm Pipe Sizing.

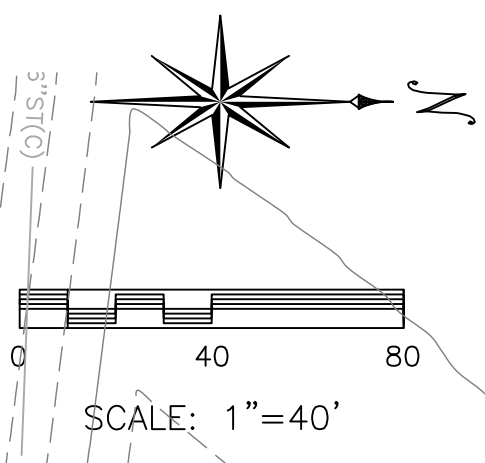

Legend

- = Drainage Area Boundary
- = Drainage Area
- = Inlet Number

