

PROJECT NOTES:

- 148EA - 140" SECTIONS
- 5EA - 144" SECTIONS
- 150EA - 42" x 29' UPRIGHTS
- 19EA - 48" x 30' UPRIGHTS
- 1480EA - 140" BEAMS
- 74EA - 144" BEAMS
- 2,331EA - 42" x 46" WIRE DECKS
- 450EA - VAULTS 60x84x80t (3 HIGH)
- 105,000 CU. FT VAULT STORAGE
- 17,648 SQFT RACKING

TOTAL PALLET POSITIONS
2,778

SCALE: Custom
SHEET: ARCH D



JOHNSON MOVING & STORAGE
 KANSAS CITY, MO

REVISIONS	
REV1	
REV2	
REV3	
REV4	
REV5	

PROJECT NUMBER:	
DATE: 11/19/2024	
DRAWN BY: SS	CHECKED BY: JC
SHEET TITLE: RACK LAYOUT	
SHEET NUMBER: 1	

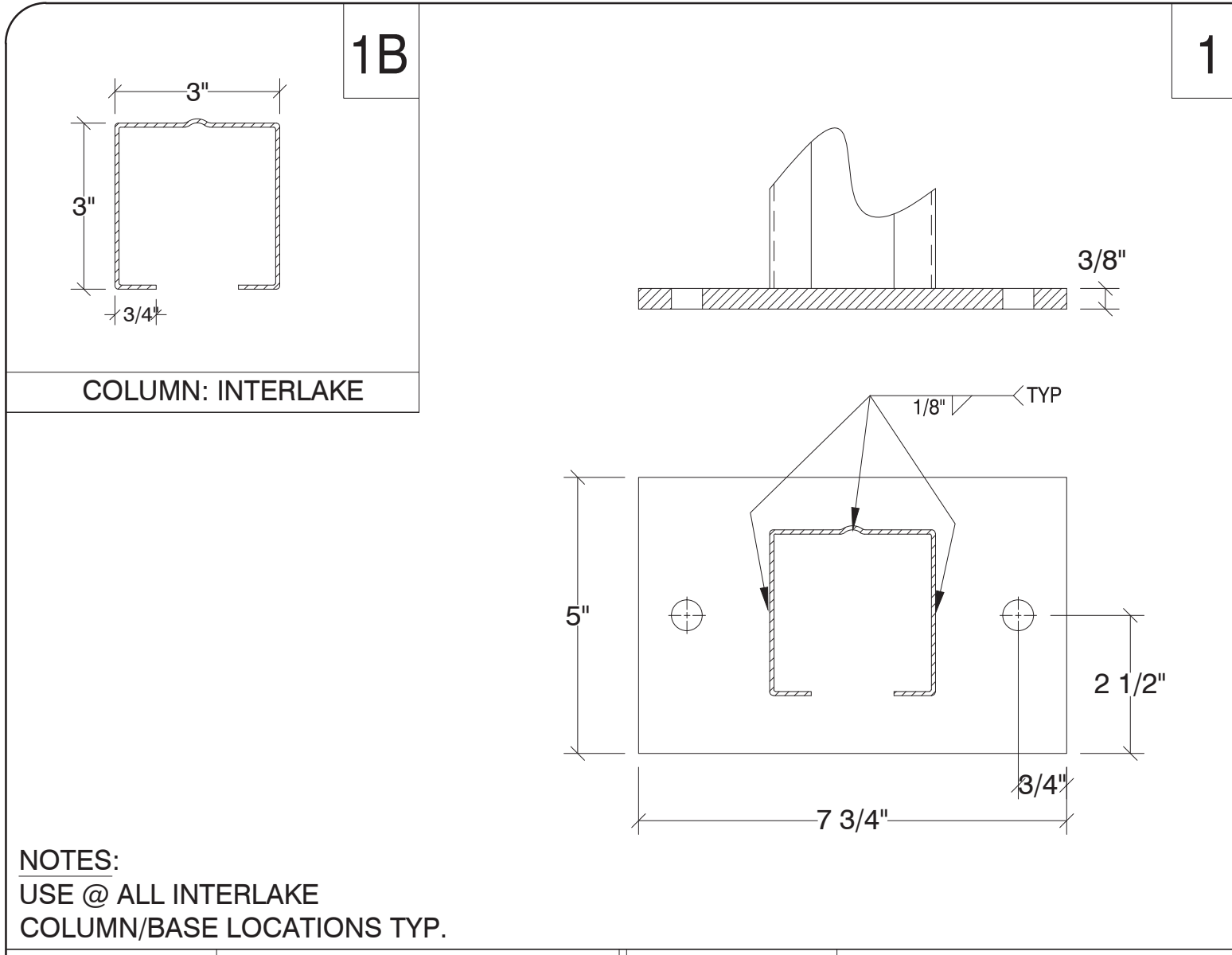

DESCRIPTION	BASE PLATE: 7-3/4" x 5"	DESCRIPTION	COLUMN: INTLK LU75
MATERIAL	3/8" THICK PLATE	MATERIAL	13 GAGE THK.
STEEL YIELD	ASTM A36, Fy=36,000 PSI	STEEL YIELD	ASTM A570, Fy=55,000 PSI

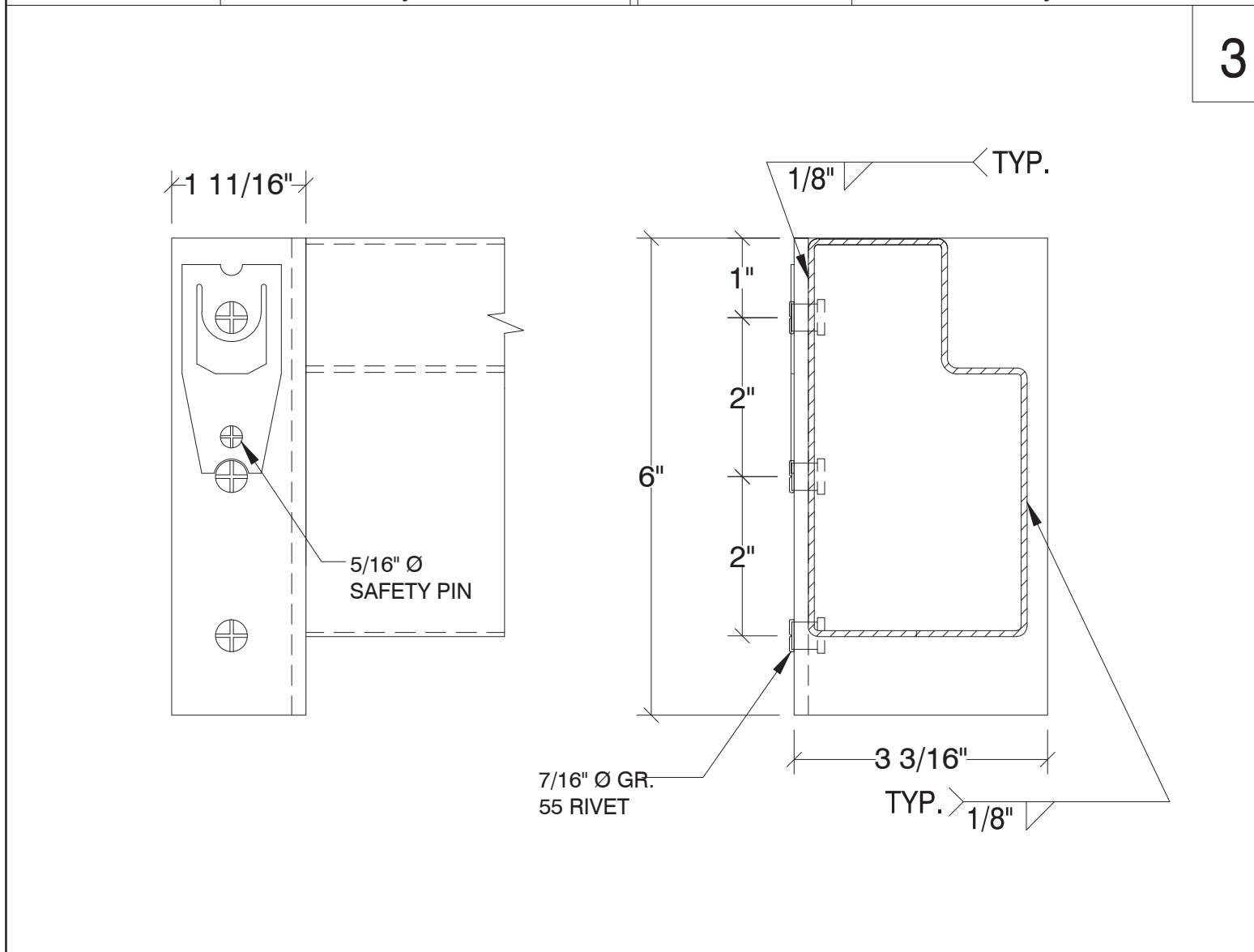

DESCRIPTION	3-PIN CONNECTOR	DESCRIPTION	5" BEAM (INTLK50E)
MATERIAL	7 GAGE	MATERIAL	16 GAGE
STEEL YIELD	ASTM A570, Fy=55,000 PSI	STEEL YIELD	ASTM A570, Fy=55,000 PSI

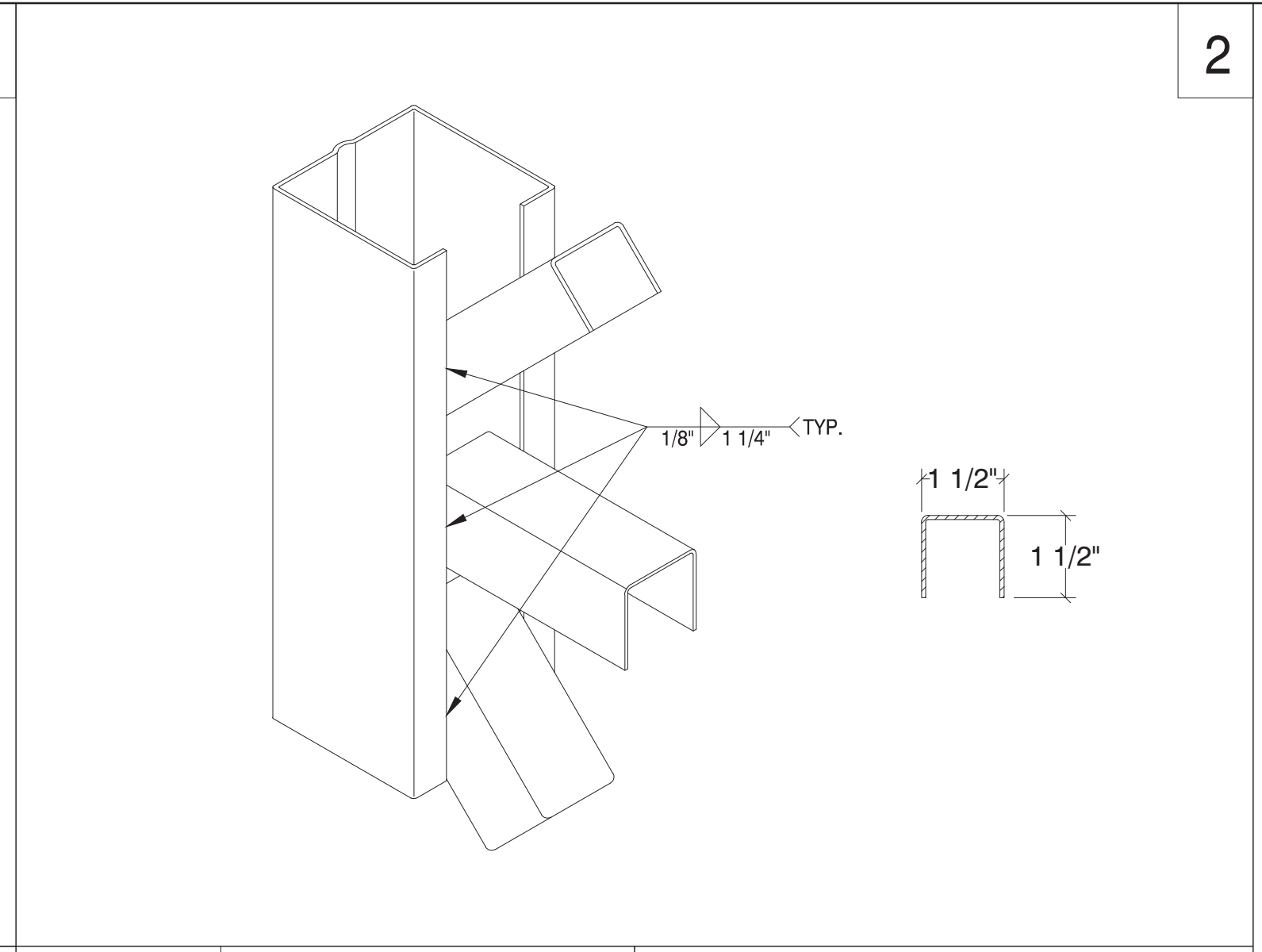

DESCRIPTION	BRACING: HORIZ. & DIAG.	NOTES:
MATERIAL	14 GAGE THK.	USE @ ALL INTLK BRACE LOCATIONS TYP.
STEEL YIELD	ASTM A570, Fy=55,000 PSI	

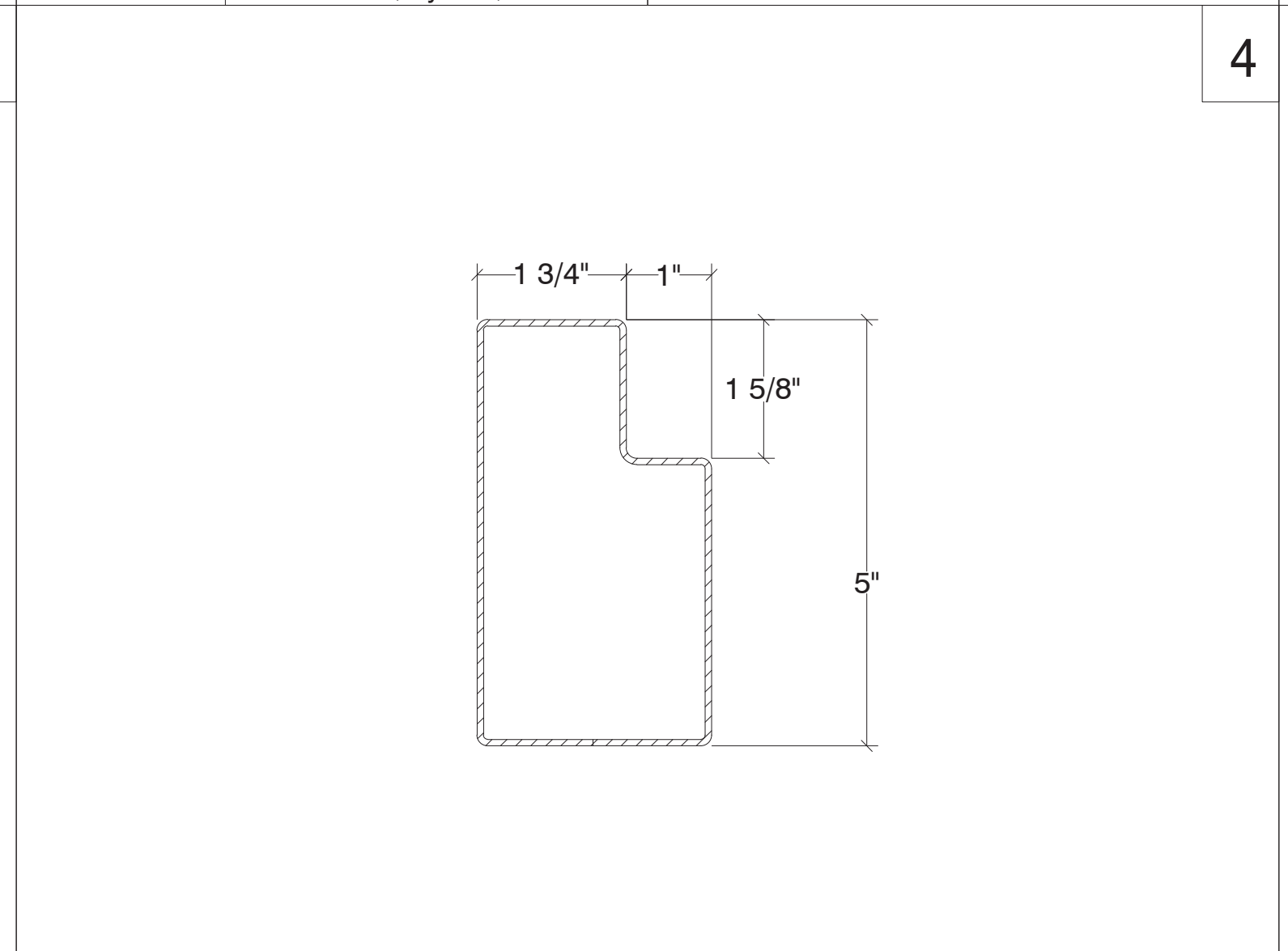

DESCRIPTION	POWERS SD1 ANCHOR	NOTES:
MATERIAL	1/2" Ø X 3-1/4" MIN. EMBED.	SEE NOTE #4 ABOVE FOR ANCHOR SPECS.
ESR#	2818	

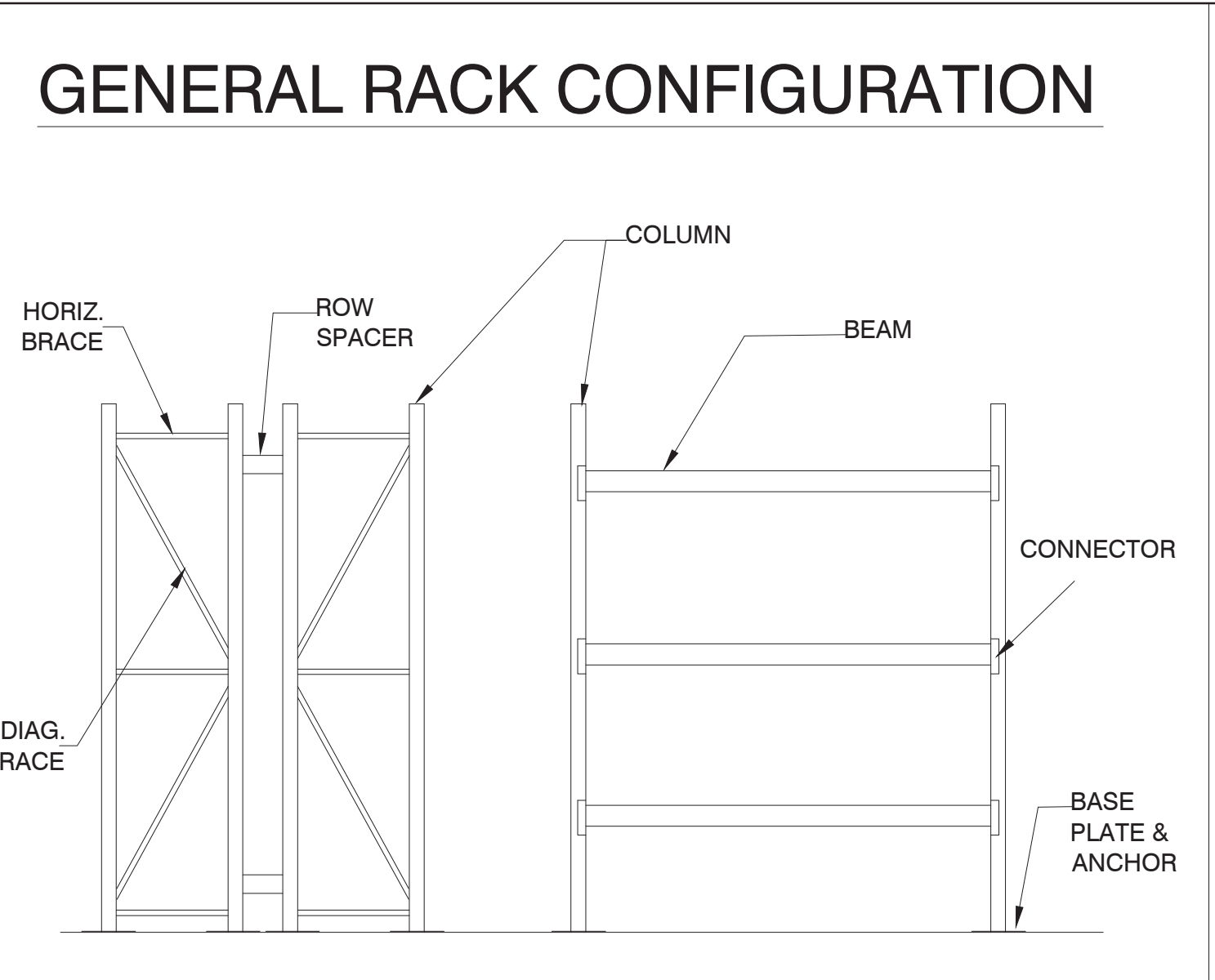

DESCRIPTION	STD ROW SPACER	NOTES:
MATERIAL	14 GAGE	ATTACH WITH (4) 3/8"Ø GR. 5 BOLTS, (2) @ EACH END
STEEL YIELD	ASTM A570, Fy = 55,000 PSI	

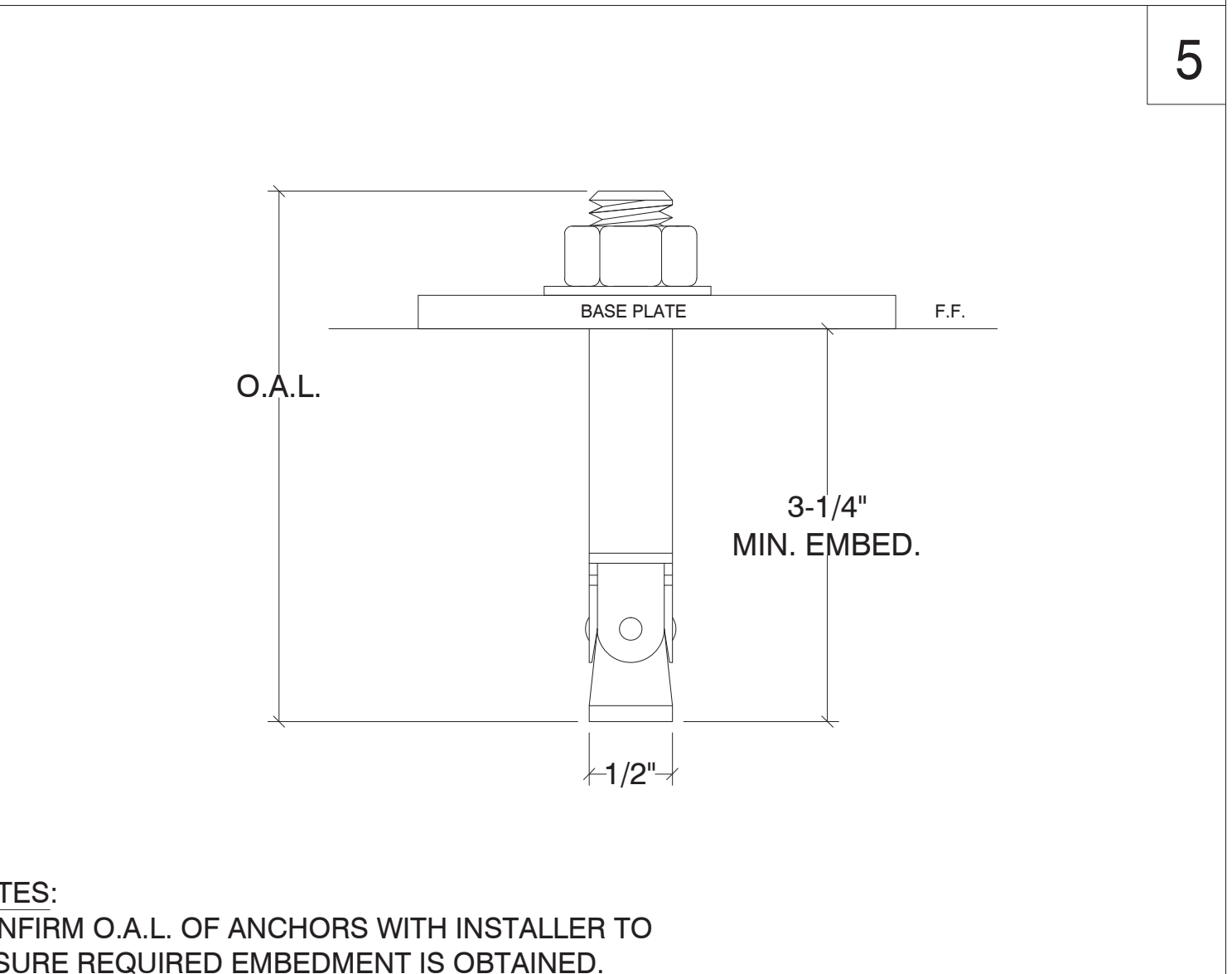

DESCRIPTION	POWERS SD1 ANCHOR	NOTES:
MATERIAL	1/2" Ø X 3-1/4" MIN. EMBED.	SEE NOTE #4 ABOVE FOR ANCHOR SPECS.
ESR#	2818	

SEE ATTACHED AMERICAN MATERIAL HANDLING DWG.
FOR STORAGE RACK ELEVATIONS

DESCRIPTION	STORAGE RACK ELEVATIONS
-------------	-------------------------

DESCRIPTION	STD ROW SPACER	NOTES:
MATERIAL	14 GAGE	ATTACH WITH (4) 3/8"Ø GR. 5 BOLTS, (2) @ EACH END
STEEL YIELD	ASTM A570, Fy = 55,000 PSI	

- ### GENERAL PROJECT NOTES
- DESIGNED PER THE REQUIREMENTS OF THE 2018 IBC, ASCE 7-16, SECTION 15.5.3, & THE 2012 RMI RACK DESIGN MANUAL.
 - SEISMIC CRITERIA SS=0.099, S1=0.068, FA=1.600, FV=2.400, IP=1.0 (NO PUBLIC ACCESS) SDS=0.106, SD1=0.109, OCCUPANCY CATAG. II SITE CLASS D, SEISMIC DESIGN CATAG. B
 - STORAGE CAPACITY:
TYPES A, B, C, D, T=4000 LBS PER LEVEL TYP.
 - ANCHORS: POWERS SD1 ESR#2818
1/2"Ø X 3-1/4" MIN. EMBED. 40 FT-LBS TORQUE.
(2) ANCHORS PER BASE PLATE.
 - PERIODIC SPECIAL INSPECTION IS REQUIRED DURING ANCHOR INSTALLATION. ANCHORS SHALL BE INSTALLED PER ICC ESR#2818.
 - EXISTING S.O.G. CONCRETE THICKNESS & COMPRESSIVE STRENGTH, 6" X 4000 PSI
 - SOIL BEARING PRESSURE 750 PSF.
 - ALL RACK INSTALLATIONS AND RACKS MANUFACTURED IN CONFORMITY WITH THIS STANDARD SHALL DISPLAY IN ONE OR MORE CONSPICUOUS LOCATIONS A PERMANENT PLAQUE EACH NOT LESS THAN 50 SQUARE INCHES IN AREA AND SHOWING THE MAXIMUM PERMISSIBLE UNIT LOAD IN CLEAR, LEGIBLE PRINT.
 - ALL BOLTS GR. 5 INSTALLED TO SNUG TIGHT FIT OR BETTER.
 - ALL WELDING PERFORMED IN THE SHOP OF AN APPROVED FABRICATOR BY AWS CERTIFIED WELDERS USING E70XX ELECTRODE OR BETTER. FIELD WELDS, IF ANY, SHALL BE PROVIDED UNDER THE SUPERVISION OF A LICENSED DEPUTY INSPECTOR. SPECIAL INSPECTION IS REQUIRED FOR ALL STRUCTURAL WELDS EXCEPT FOR WELDING DONE IN AN APPROVED FABRICATOR'S SHOP.
 - THE CLEAR SPACE BELOW SPRINKLERS SHALL BE A MIN. OF 18" BETWEEN TOP OF THE STORAGE AND THE CEILING SPRINKLER DEFLECTOR.
 - THE PRODUCT SHOWN ON THE DETAILS HEREIN IS ASSUMED TO BE IN GOOD, UNDAMAGED CONDITION. THE PRODUCT MUST BE FREE OF ANY DAMAGE AND/OR FABRICATION DEFICIENCIES OR IRREGULARITIES. IT IS THE RESPONSIBILITY OF THE OWNER, USER, PRODUCT PROVIDER AND/OR INSTALLER OF THE COMPONENTS TO NOTIFY SED, INC IN WRITING, OF ANY DAMAGE, DEFICIENCIES OR IRREGULARITIES.
 - IT IS THE RESPONSIBILITY OF THE OWNER AND/OR USER OF THE COMPONENTS SHOWN HEREIN TO NOTIFY SED, INC OF ANY DAMAGE OR DEFICIENCIES IN THE SYSTEM DURING USE. THIS INCLUDES SUCH OCCURRENCES SUCH AS IMPACT DAMAGE TO THE COMPONENTS FROM FORKLIFT OR HEAVY MACHINERY, IMPACT FROM DROPPED LOADS ON THE SYSTEM, DAMAGE TO SYSTEMS BY IMPROPER USE OR INSTALLATION, ETC. THE USER OF THE PRODUCT MUST NOTIFY SED, INC IN WRITING SHOULD ANY DAMAGE OR DEFICIENCY OCCUR TO THE PRODUCT SHOWN HEREIN. IT IS THE RESPONSIBILITY OF THE OWNER AND/OR USER TO MAINTAIN THE SAFETY AND PROPER USE OF THE STORAGE PRODUCT SHOWN HEREIN.
 - IT IS THE RESPONSIBILITY OF THE OWNER/USER OF THE STORAGE SYSTEM SHOWN HEREIN TO REPAIR OR REPLACE ANY COMPONENT THAT IS DAMAGED OR OTHERWISE DEFICIENT.
 - THE OWNER SHALL MAINTAIN THE STRUCTURAL INTEGRITY OF THE RACK SYSTEM BY ASSURING PROPER OPERATIONAL, HOUSE KEEPING AND MAINTENANCE PROCEDURES, BUT NOT LIMITED TO THE FOLLOWING:
A. PROHIBIT ANY OVER LOADING OF ANY PALLET POSITIONS AND OF OVERALL RACK SYSTEMS.
B. REGULARLY INSPECT FOR DAMAGE. IF DAMAGE IS FOUND, IMMEDIATELY UNLOAD THE AFFECTED AREA AND REPLACE OR REPAIR ANY DAMAGED COLUMNS, BEAMS, OR OTHER STRUCTURAL COMPONENTS.
C. REQUIRE ALL PALLETS TO BE MAINTAINED IN GOOD, SAFE, OPERATING CONDITION.
D. ENSURE THAT PALLETS ARE PROPERLY PLACED ONTO PALLET LOAD SUPPORT MEMBERS IN PROPERLY STACKED AND STABLE POSITION.
E. REQUIRE THAT ALL GOODS STORED ON EACH PALLET TO BE PROPERLY STACKED AND STABLE.
F. PROHIBIT DOUBLE STACKING OF ANY PALLET POSITION, INCLUDING THE TOP MOST POSITION, UNLESS THE RACK SYSTEM IS SPECIFICALLY DESIGNED FOR SUCH LOADING.
G. THE OWNER AND/OR USER OF THE RACK SYSTEM MUST PROVIDE MEASURES TO MITIGATE DAMAGE TO THE STORAGE RACK BY USE OF IMPACT PROTECTIVE DEVICES IN AREAS WHERE FORKLIFT AND/OR HEAVY MACHINERY ARE IN USE.
H. ENSURE THAT THE RACKS ARE NOT MODIFIED OR REARRANGED IN A MANNER NOT WITHIN THE ORIGINAL DESIGN CONFIGURATION.



CLIENT: AMERICAN MATERIAL HANDLING	DATE: 11/20/2024	DRAWN BY: J.M.	ENG. BY: M.O.Z.
		MFG.: INTERLAKE	TYP.: STORAGE RACK
JOHNSON STORAGE AND MOVING 2225 NE TOWNE CENTRE BLVD LEES SUMMIT, MO 64064			
STRUCTURAL ENGINEERING & DESIGN INC. 1515 WRIGHT AVE. LA VERNE, CA 91750 PHONE 909.590.1351 FAX 909.590.7165			
JOB NO.	24-1119-12		
SHEET NO.	SED 1 OF 1		