

RIGHT ELEVATION

SCALE: 1/8" = 1'-0"

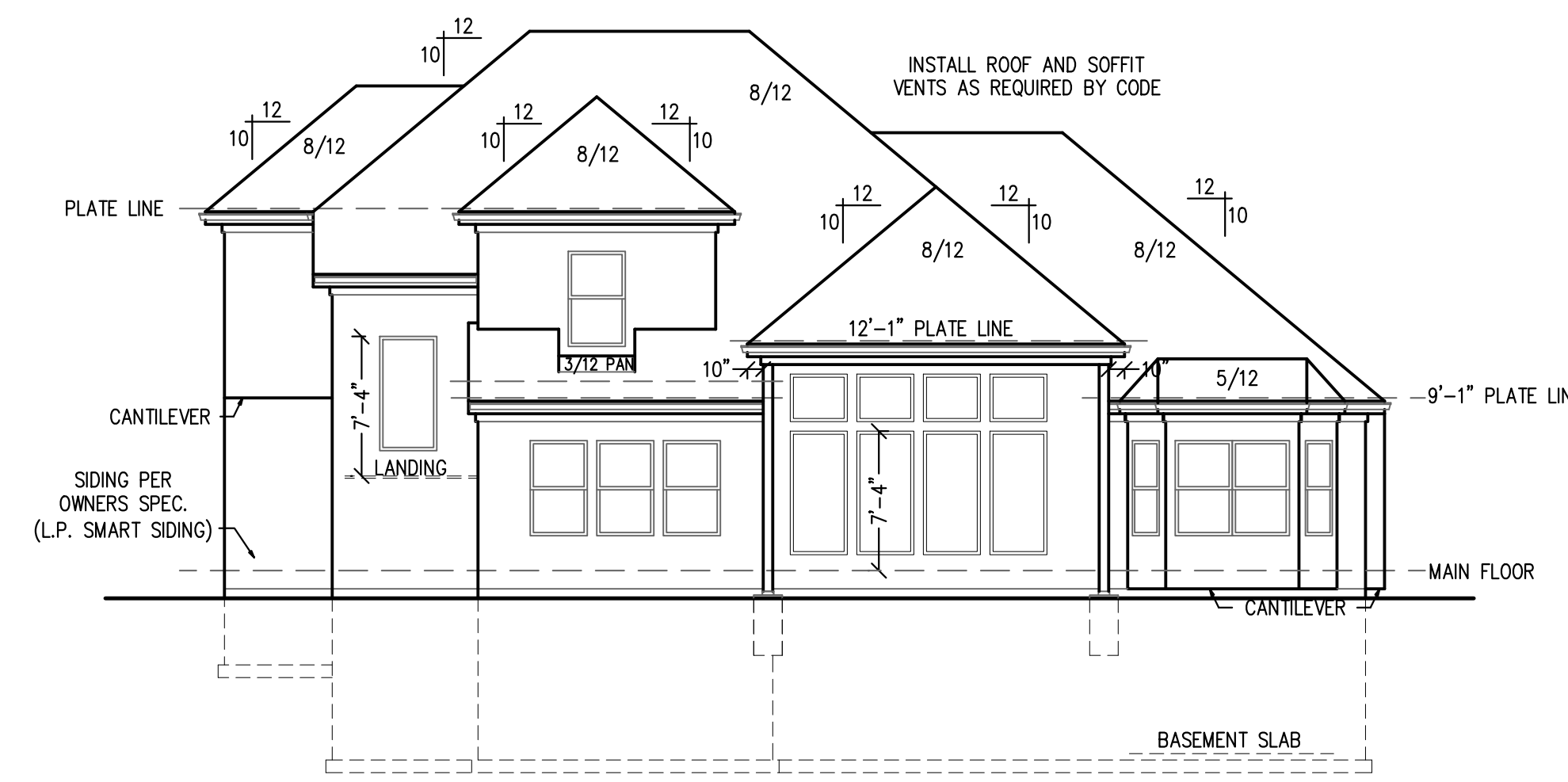

REAR ELEVATION

SCALE: 1/8" = 1'-0"

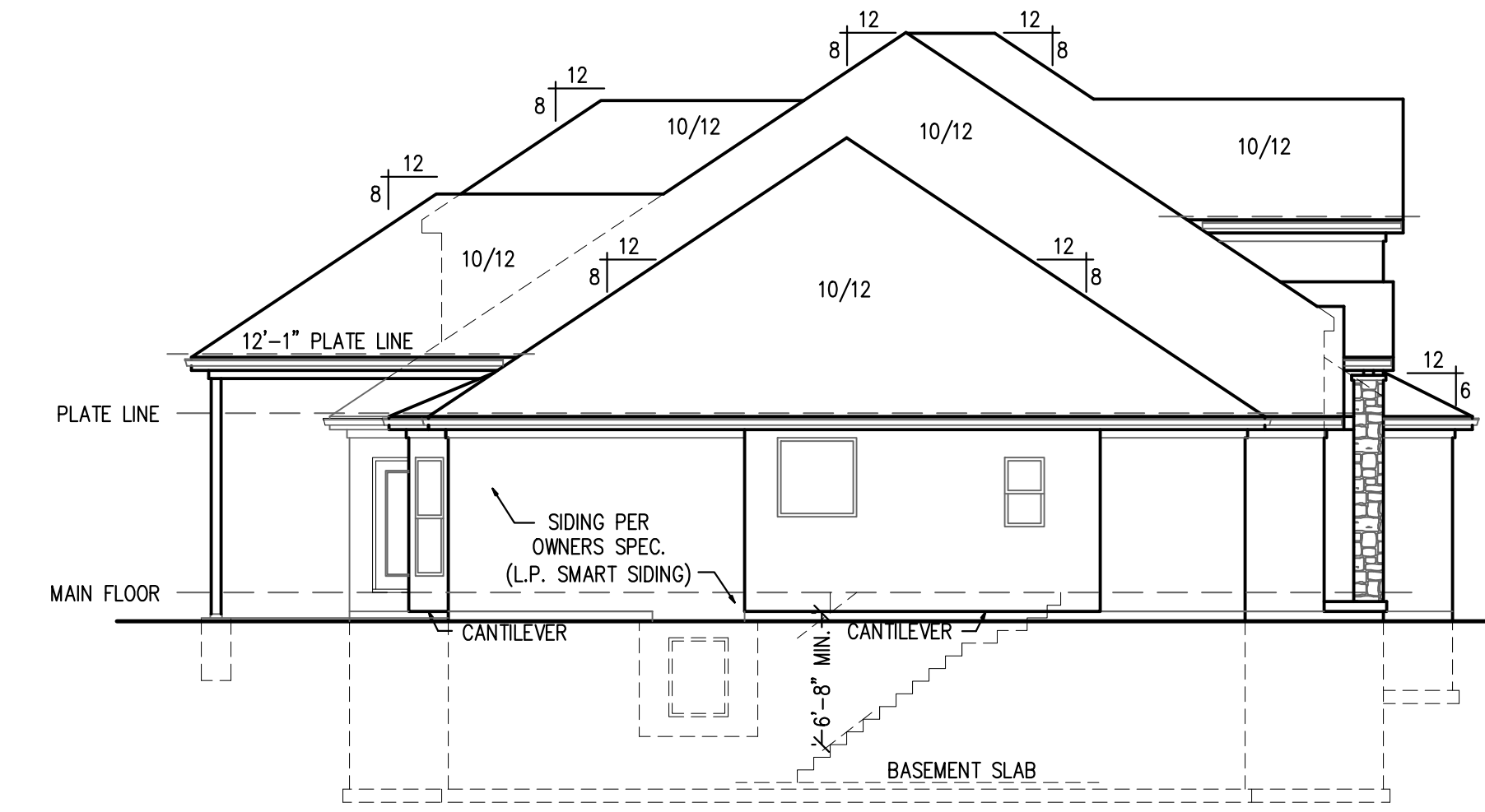

LEFT ELEVATION

SCALE: 1/8" = 1'-0"

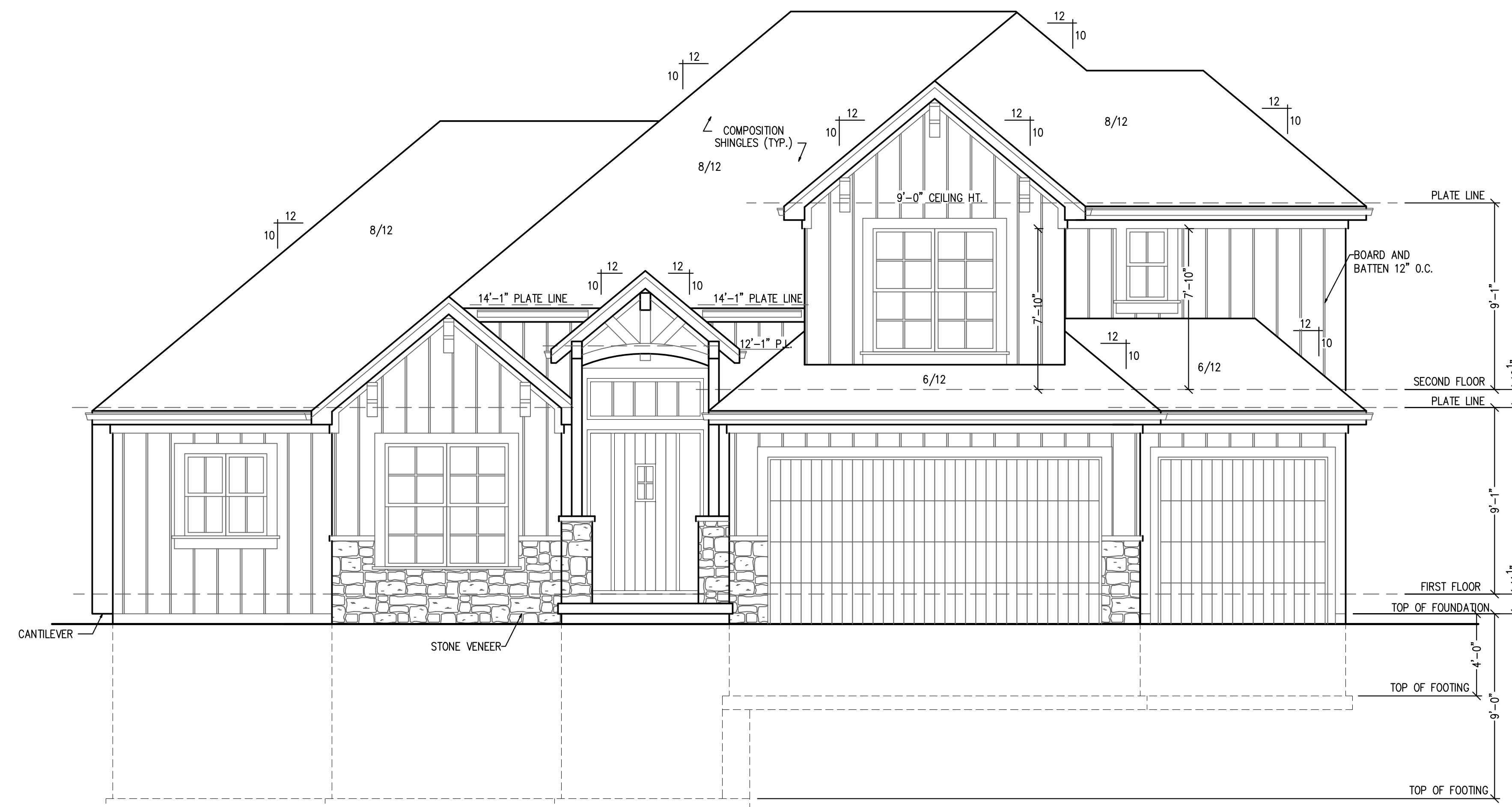

FRONT ELEVATION

SCALE: 1/4" = 1'-0"

RELEASE FOR CONSTRUCTION
AS NOTED FOR PLAN REVIEW
DEVELOPMENT SERVICES
LEE'S SUMMIT, MISSOURI
11/07/2024

LOWER LEVEL -	25 SQ. FT.
MAIN FLOOR -	1,863 SQ. FT.
SECOND FLOOR -	970 SQ. FT.
TOTAL	2,958 SQ. FT.
PORCH	216 SQ. FT.
GARAGE	710 SQ. FT.
UNFINISHED	1,750 SQ. FT.

DISCLAIMER
ACTUAL PLANS AND ELEVATIONS MAY VARY FROM ARCHITECTURAL DRAWINGS. DUE TO TERRAIN/BACKFILL PROCESS. FRONT ELEVATIONS ARE ARCHITECTURAL DRAWINGS AND MAY VARY DUE TO MATERIAL AVAILABILITY.

NOTE:
PLANS DESIGNED PER IRC AS ADOPTED BY GOVERNING JURISDICTION

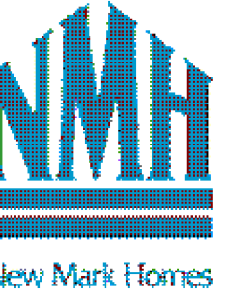

APEX ENGINEERS, INC.
1926 LOCUST ST.
KANSAS CITY, MO 64108
916-421-3222
STRUCTURAL DESIGN REVIEW
KANSAS ENGINEERING LICENSE: 952
MISSOURI ENGINEERING LICENSE: 200004673

DRAWN BY: CJD

CHECKED BY: CA

DATE: 10/16/2024

A1

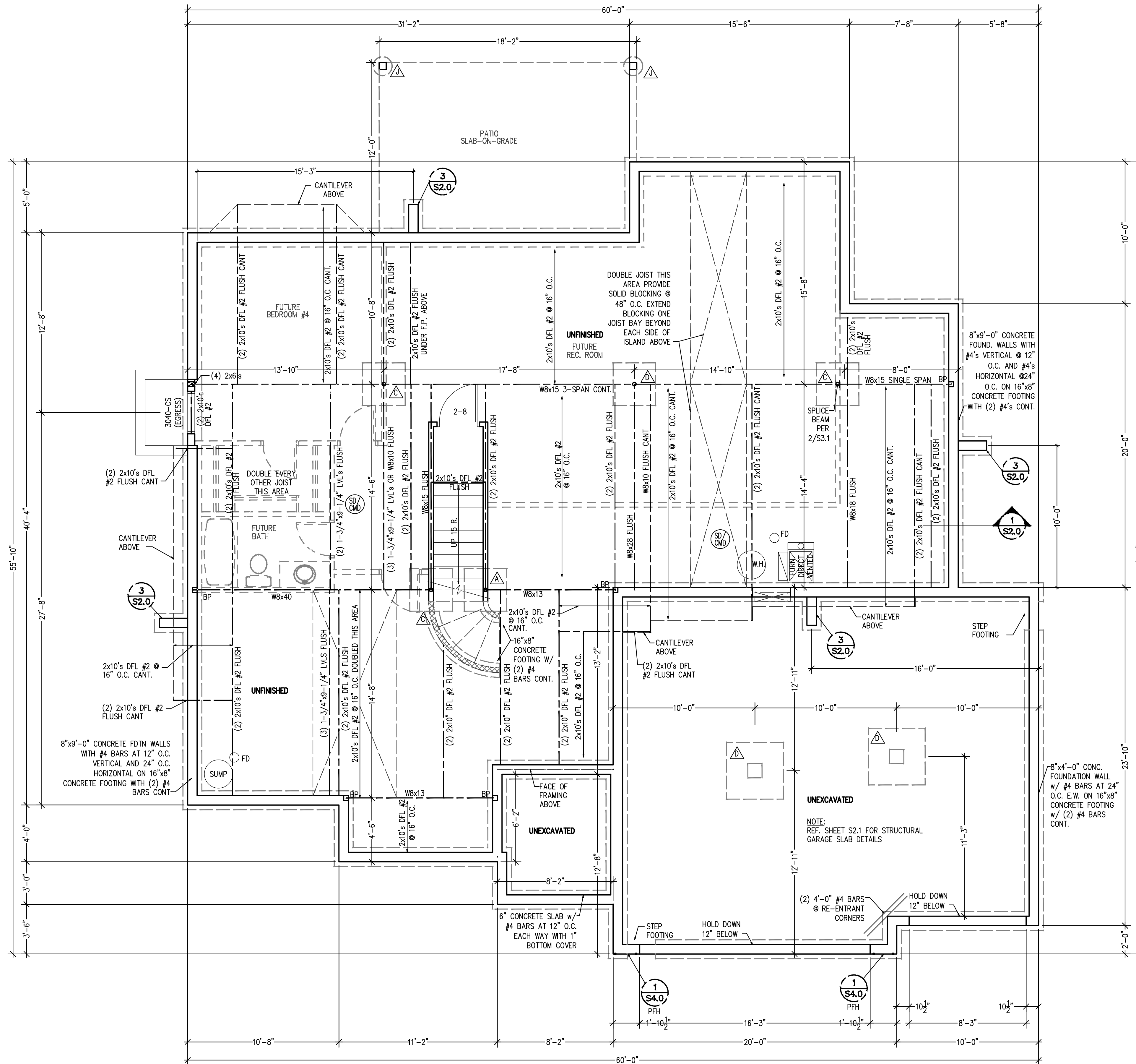

FOUNDATION PLAN
SCALE: 1/4" = 1'-0"

STRUCTURAL NOTES:
 - ALL UNMARKED HEADERS MIN (2)#2-2x10
 - ALL HEADERS AND BEAMS MIN #2 GRADE DFL (OR EQ.)
 - [Symbol] = BEARING WALL
 - STRUCTURE NOTED AS FLUSH TO BE FLUSH WITH SUB-FLOOR ABOVE.
BRACED WALL METHODOLOGY
 CONTINUOUS EXTERIOR SHEATHING PER WSP METHOD (BELOW) UNLESS OTHERWISE NOTED ON THE PLAN
XXXX EXTERIOR BRACED WALLS:
 WSP METHOD: WOOD STRUCTURAL PANEL SHEATHING WITH A THICKNESS NOT LESS THAN 3/8" WITH MINIMUM SPAN RATING OF 24/0 FOR 16" OC STUD SPACING WITH 6d COMMON NAILS AT 6" OC EDGES AND 12" OC FIELD OR SHEATHING THICKNESS NOT LESS THAN 7/8" WITH MINIMUM SPAN RATING OF 24/0 FOR 24" OC SPACING WITH 8d COMMON NAILS AT 6" OC EDGES AND 12" OC IN FIELD.
 (NOTE: FRAMING MEMBERS 1" OC MAX. UNBLOCKED, AND WITH SHEATHING APPLIED DIRECTLY TO FRAMING MEMBERS)
//// INTERIOR BRACED WALLS (REF 2-S4.0):
 GB METHOD: 1/2" MIN. GYPSUM BOARD OVER STUDS SPACED 24" MAX. FASTENED WITH No 6 - 1/2" TYPE "W" OR "S" DRYWALL SCREWS AT 7" OC EDGES AND FIELD (MIN. 4'-0" SECTION FOR BOTH SIDES.)
 OR
 LIB METHOD: 1x4 WOOD FASTENED WITH (3) 8d COMMON NAILS OR SIMPSON / USP 16 GA. TYPE WB (OR EQUAL) STL. X-BRACE(S) AT 45° TO 60° ANGLES, MAXIMUM 16" O.C. STUD FASTENED PER MANUFACTURER'S SPECIFICATIONS.

COLUMN & PIER PAD SCHEDULE (REF. 5/S2.0)

COLUMN MARK	PAD SIZE	REINFORCEMENT	COLUMN SIZE
A	30" x 30" x 12"	(4) #4 BAR E.W.	3" SCH 40 (3.5" OD)
B	36" x 36" x 12"	(4) #4 BAR E.W.	(4) #4 BAR E.W. 3" SCH 40 (3.5" OD)
C	42" x 42" x 12"	(5) #4 BAR E.W.	3" SCH 40 (3.5" OD)
D	48" x 48" x 12"	(6) #4 BAR E.W.	3/2" SCH 40 (4" OD)
E	54" x 54" x 16"	(8) #4 BAR E.W.	REF PLAN
F	60" x 60" x 16"	(10) #4 BAR E.W.	REF PLAN

- COLUMN & PAD SIZES SHOWN ARE FOR MAXIMUM ADJUSTABLE COLUMN HEIGHT OF 9'-1". REQUIRES SEPARATE ENGR DESIGN IF GREATER THAN 9'-1" TALL. COLUMNS SIZED AS QWIK-ADJUST COLUMN, BY QUALITY WAY PRODUCTS, LLC. REFER TO SAFE LOADING CAPACITIES PER MANUF SPECS, OR SUBSTITUTION TO ANOTHER PRODUCT ONLY WITH PRIOR APPROVAL BY APEX ENGINEERS.
- COLUMN & PIER PAD SIZES SHOWN ARE BASED ON AN ASSUMED MINIMUM ALLOWABLE SOIL BEARING CAPACITY OF 2,000PSF.

COLUMN & PIER SCHEDULE

MARK	COLUMN SIZE	PIER DIA.
A	6x6	12"
B	6x6	16"
C	6x6	18"
D	6x6	24"
E	6x6	28"

- ALL PIERS TO BEAR ON ORIGINAL UNDISTURBED SOIL OF 2,000 PSF BEARING CAPACITY OR FILL COMPACTED AND TESTED TO CONFORM TO THE RECOMMENDATIONS OF A GEOTECHNICAL ENGINEER.
- PIERS SHALL EXTEND BELOW THE FROST LINE: MIN. DEPTH OF 36" BELOW GRADE.
- POST SHALL BE TREATED OR CEDAR WITH SIMPSON ABU66 POST BASE

- DETAIL REFERENCES**
- 1 S2.0 TYPICAL FOUNDATION WALL DETAIL
 - 2 S2.1 TYPICAL "UNRESTRAINED" FOUNDATION WALL DETAIL
 - 3 S2.0 TYPICAL DEAD MAN DETAIL
 - 4 S2.0 FOUNDATION WALL JUMP DETAIL
 - 5 S2.0 COLUMN PAD DETAIL
 - 1 S2.1 TYPICAL STRUCTURAL GARAGE SLAB PLAN
 - 2 S2.1 STRUCTURAL GARAGE SLAB PIER PAD DETAIL
 - 3 S2.1 STRUCTURAL GARAGE SLAB / WALL SECTION
 - 6 S2.0 TYPICAL OVERDIG DETAIL AT BASEMENT SLAB
 - 1 S4.0 ALTERNATE BRACED WALL PANEL DETAIL
 - 1 S4.0 APA NARROW WALL BRACING METHOD WITHOUT HOLD-DOWNS ALT.
 - 1 S4.0 COLUMN AND PIER PAD SCHEDULE (SHEET S2.0)

EXPANSIVE SOILS DISCLAIMER:
 THESE PLANS HAVE BEEN PREPARED BASED ON A PRESUMPTIVE ALLOWABLE BEARING CAPACITY AS ALLOWED BY IRC CODE AND THE LOCAL ENFORCING JURISDICTION.
 APEX ENGINEERS, INC. (APEX) RECOMMENDS THAT ALL FOOTING EXCAVATIONS BE EVALUATED BY A LICENSED GEOTECHNICAL ENGINEER PRIOR TO THE PLACEMENT OF ANY FOUNDATION ELEMENTS. GEOTECHNICAL INVESTIGATION AND/OR TESTING IS NOT A SERVICE PROVIDED OR OFFERED BY APEX.
 APEX HAS NOT BEEN RETAINED TO DETERMINE THE EXPANSIVE SOIL CHARACTERISTICS OF THE SUBGRADE SOIL AND THEREFORE CANNOT BE HELD RESPONSIBLE FOR THE VOLUMETRIC CHANGES OF THE SOIL (INCLUDING BELOW THE BASEMENT SLAB), BY USE OF THESE PLANS WITHOUT AN ACCOMPANYING GEOTECHNICAL ENGINEERING REPORT. APEX SHALL NOT BE HELD LIABLE FOR ANY FUTURE MOVEMENT AND/OR DIFFERENTIAL MOVEMENT OF THE PROPOSED STRUCTURE AND THE POSSIBLE DAMAGE THAT MAY BE CAUSED AS A RESULT OF SUCH MOVEMENT. DAMAGE FROM EXPANSIVE SOILS AND/OR SETTLEMENT CAN RESULT IN AMONGST OTHER THINGS, THE FOLLOWING: BASEMENT SLAB HEAVE, SHEETROCK CRACKS, WINDOWS AND DOOR BECOMING OUT OF PLUMB AND STICKING AND/OR NOT OPENING, DAMAGE TO TILE, MOULDING, AND OTHER COSMETIC FINISHES.

ALL WINDOWS SIZES ARE EXPRESSED IN FEET AND INCHES TO THE UNIT SIZE.

New Mark Homes
 P.O. Box 12025
 Parkville, Missouri 64152
 Ph. (816) 969-9010

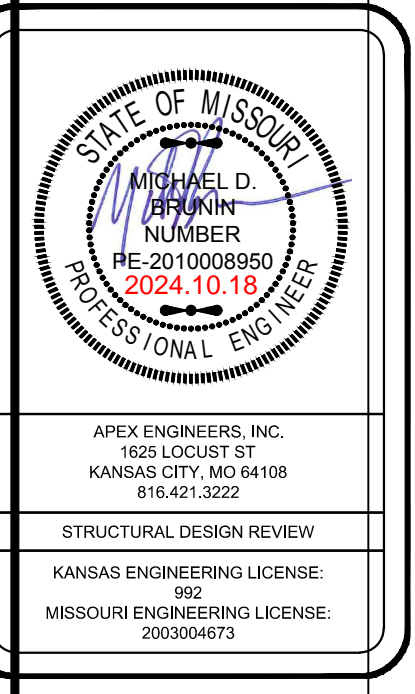

The Hiltner Residence
 2805 SW Heathstone Pl - Hook Farms - Lot 81
 Lees Summit, Missouri
 Copyright 2024

DRAWN BY: CJD
 CHECKED BY: CA
 DATE: 10/16/2024

NOTE:
 PLANS DESIGNED PER IRC AS ADOPTED BY GOVERNING JURISDICTION

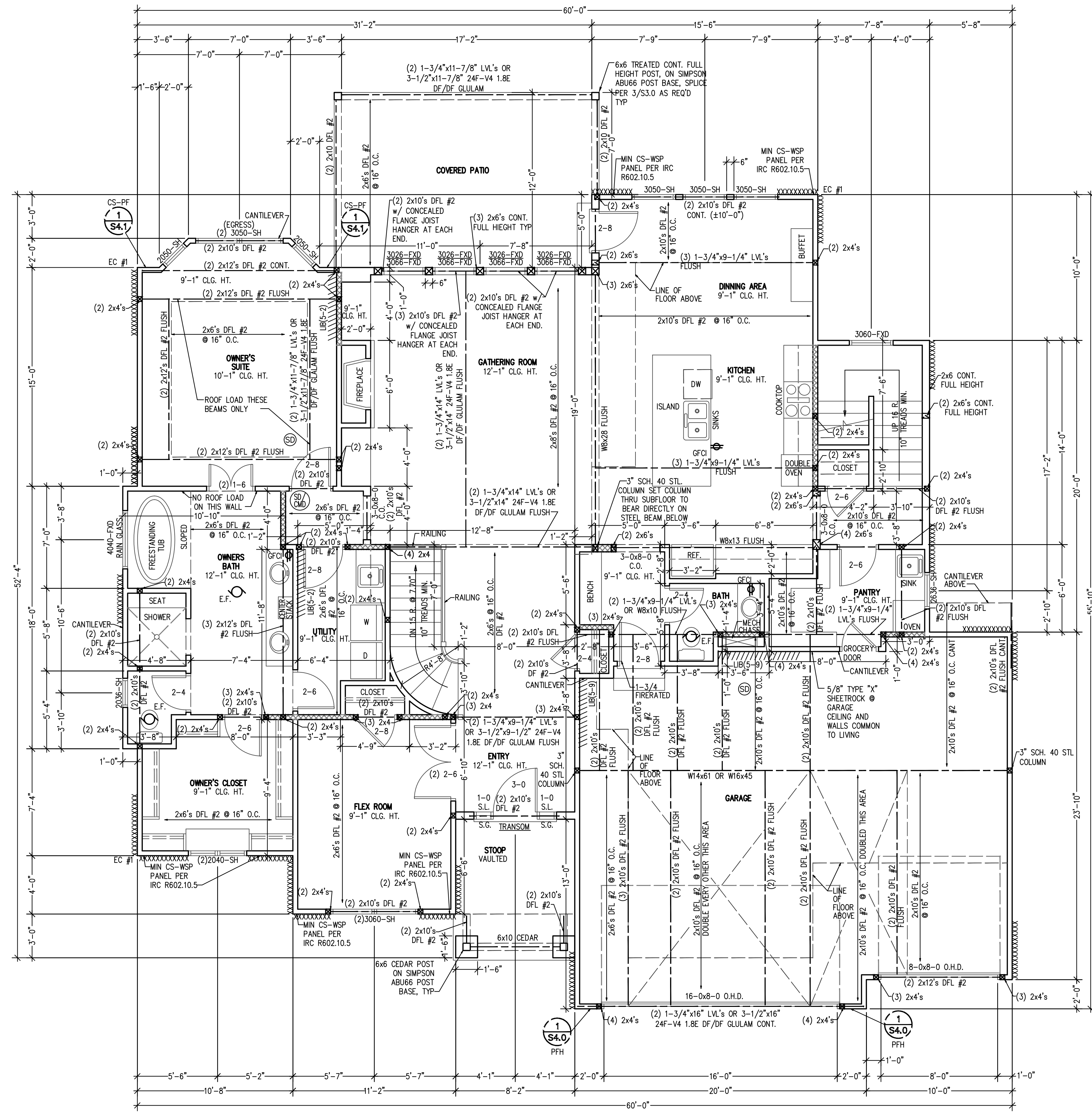

MAIN FLOOR PLAN
SCALE: 1/4" = 1'-0"

*ALL WINDOWS TO HAVE U = 0.4 OR LESS.

ALL WINDOWS SIZES ARE EXPRESSED IN FEET AND INCHES TO THE UNIT SIZE.

STRUCTURAL NOTES:
- ALL UNMARKED HEADERS MIN (2)#2-2x10
- ALL HEADERS AND BEAMS MIN #2 GRADE DFL (OR EQ.)
- BEARING WALL
- STRUCTURE NOTED AS FLUSH TO BE FLUSH WITH SUB-FLOOR ABOVE.

BRACED WALL METHODOLOGY
CONTINUOUS EXTERIOR SHEATHING PER WSP METHOD (BELOW) UNLESS OTHERWISE NOTED ON THE PLAN

XXXX EXTERIOR BRACED WALLS:

WSP METHOD: WOOD STRUCTURAL PANEL SHEATHING WITH A THICKNESS NOT LESS THAN 3/4" WITH MINIMUM SPAN RATING OF 24/0 FOR 16" OC STUD SPACING WITH 6d COMMON NAILS AT 6" OC EDGES AND 12" OC FIELD OR SHEATHING THICKNESS NOT LESS THAN 5/8" WITH MINIMUM SPAN RATING OF 24/0 FOR 24" OC SPACING WITH 8d COMMON NAILS AT 6" OC EDGES AND 12" OC IN FIELD. (NOTE: FRAMING MEMBERS 16" OC MAX UNBLOCKED, AND WITH SHEATHING APPLIED DIRECTLY TO FRAMING MEMBERS)

///// INTERIOR BRACED WALLS (REF 2-S4.0):

GB METHOD: 1/2" MIN. GYPSUM BOARD OVER STUDS SPACED 24" MAX. FASTENED WITH No 6 - 1/2" TYPE 'W' OR 'S' DRYWALL SCREWS AT 7" OC EDGES AND FIELD (MIN. 4'-0" SECTION FOR BOTH SIDES.)

OR

LIB METHOD: 1x4 WOOD FASTENED WITH (3) 8d COMMON NAILS OR SIMPSON / USP 16 GA. TYPE WB (OR EQUAL) STL. X-BRACE(S) AT 45° TO 60° ANGLES, MAXIMUM 16" O.C. STUD FASTENED PER MANUFACTURER'S SPECIFICATIONS.

New Mark Homes
P.O. Box 12025
Parkville, Missouri 64152
Ph. (816) 969-9010

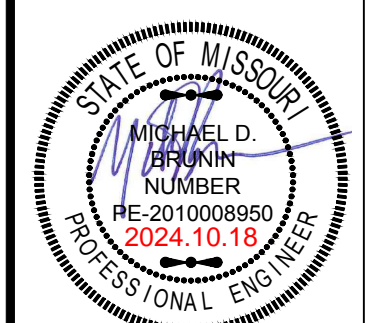

APEX ENGINEERS, INC.
1926 LOCUST ST
KANSAS CITY, MO 64108
816-421-3222
STRUCTURAL DESIGN REVIEW
KANSAS ENGINEERING LICENSE: 952
MISSOURI ENGINEERING LICENSE: 200004672

The Hilmer Residence
2805 SW Heathstone Pl - Hook Farms - Lot 81
Lees Summit, Missouri
© Copyright 2024

DRAWN BY: CJD
CHECKED BY: CA
DATE: 10/16/2024

RELEASE FOR CONSTRUCTION
AS NOTED FOR PLAN REVIEW
(DEVELOPMENT SERVICES)
LEES SUMMIT, MISSOURI
PROJ. 117072024

NOTE:
PLANS DESIGNED PER IRC AS ADOPTED BY GOVERNING JURISDICTION

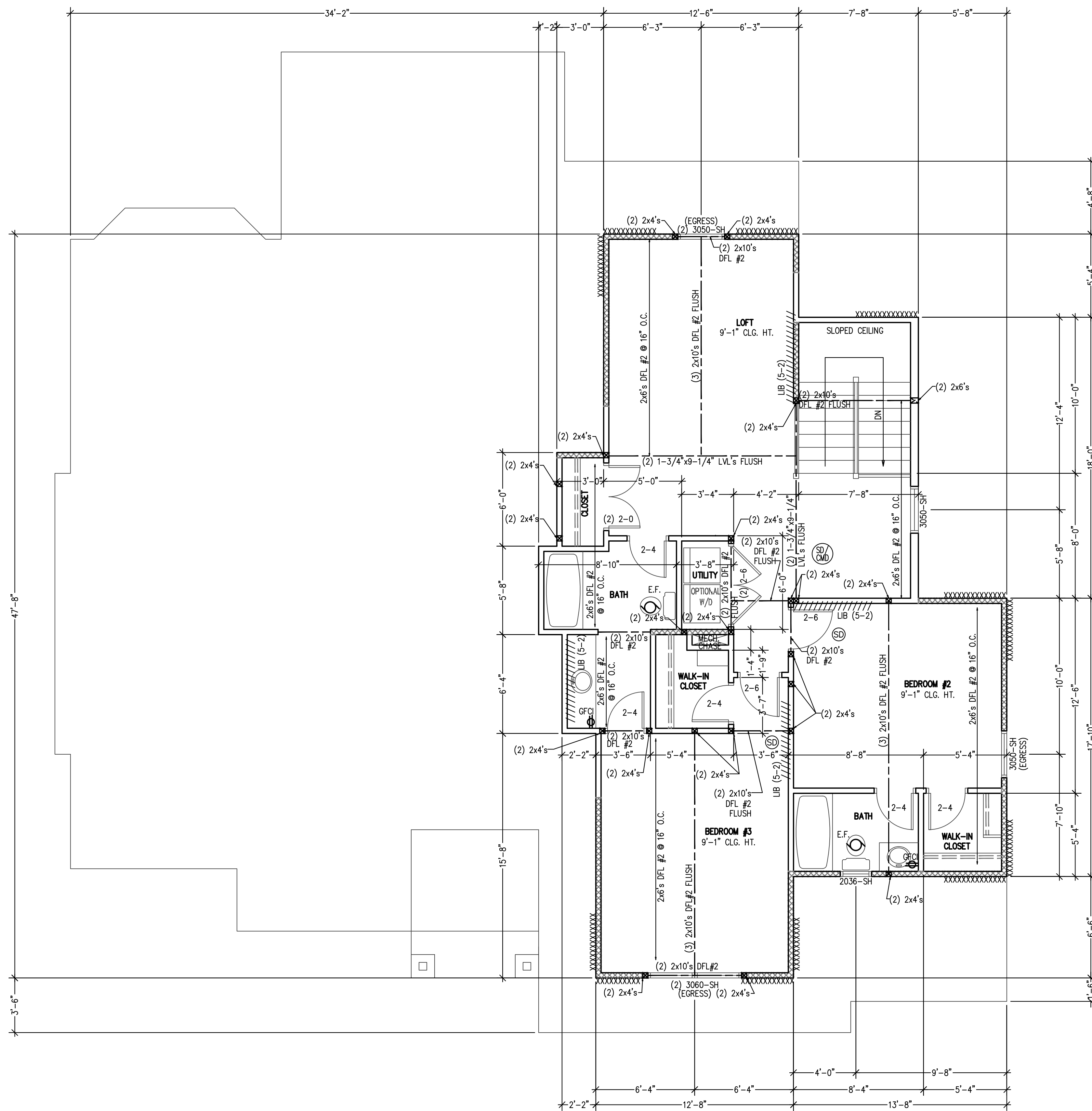

SECOND FLOOR PLAN
SCALE: 1/4" = 1'-0"

STRUCTURAL NOTES:
- ALL UNMARKED HEADERS MIN (2)#2-2x10
- ALL HEADERS AND BEAMS MIN #2 GRADE DFL (OR EQ.)
- [XXXXXX] = BEARING WALL

BRACED WALL METHODOLOGY
CONTINUOUS EXTERIOR SHEATHING PER WSP METHOD (BELOW) UNLESS OTHERWISE NOTED ON THE PLAN

XXXX EXTERIOR BRACED WALLS:

WSP METHOD: WOOD STRUCTURAL PANEL SHEATHING WITH A THICKNESS NOT LESS THAN 3/8" WITH MINIMUM SPAN RATING OF 24/0 FOR 16" OC STUD SPACING WITH 6d COMMON NAILS AT 6" OC EDGES AND 12" OC FIELD OR SHEATHING THICKNESS NOT LESS THAN 7/8" WITH MINIMUM SPAN RATING OF 24/0 FOR 24" OC SPACING WITH 8d COMMON NAILS AT 6" OC EDGES AND 12" OC IN FIELD.
(NOTE: FRAMING MEMBERS 16" OC MAX UNBLOCKED, AND WITH SHEATHING APPLIED DIRECTLY TO FRAMING MEMBERS)

//// INTERIOR BRACED WALLS (REF 2-S4.0):

GB METHOD: 1/2" MIN. GYPSUM BOARD OVER STUDS SPACED 24" MAX. FASTENED WITH No 6 - 1 1/2" TYPE 'W' OR 'S' DRYWALL SCREWS AT 7" OC EDGES AND FIELD (MIN. 4'-0" SECTION FOR BOTH SIDES.)
OR

LIB METHOD: 1x4 WOOD FASTENED WITH (3) 8d COMMON NAILS OR SIMPSON / USP 16 GA. TYPE WB (OR EQUAL) STL. X-BRACE(S) AT 45° TO 60° ANGLES, MAXIMUM 16" O.C. STUD FASTENED PER MANUFACTURER'S SPECIFICATIONS.

*ALL WINDOWS TO HAVE U = 0.4 OR LESS.

ALL WINDOWS SIZES ARE EXPRESSED IN FEET AND INCHES TO THE UNIT SIZE.

NOTE:
PLANS DESIGNED PER IRC AS ADOPTED BY GOVERNING JURISDICTION

New Mark Homes
P.O. Box 12025
Parkville, Missouri 64152
Ph. (816) 969-9010

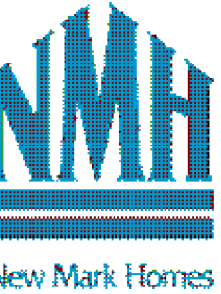

APEX ENGINEERS, INC.
1928 LOCUST ST
KANSAS CITY, MO 64108
816-421-3222

STRUCTURAL DESIGN REVIEW
KANSAS ENGINEERING LICENSE: 952
MISSOURI ENGINEERING LICENSE: 200004673

The Hilmer Residence
2805 SW Heathstone Pl - Hook Farms - Lot 81
Lees Summit, Missouri
© Copyright 2024

DRAWN BY: CJD
CHECKED BY: CA
DATE: 10/16/2024

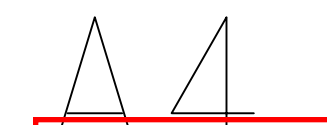

RELEASE FOR CONSTRUCTION AS NOTED FOR PLAN REVIEW DEVELOPMENT SERVICES LEES SUMMIT, MISSOURI
PROJ. 11/07/2024

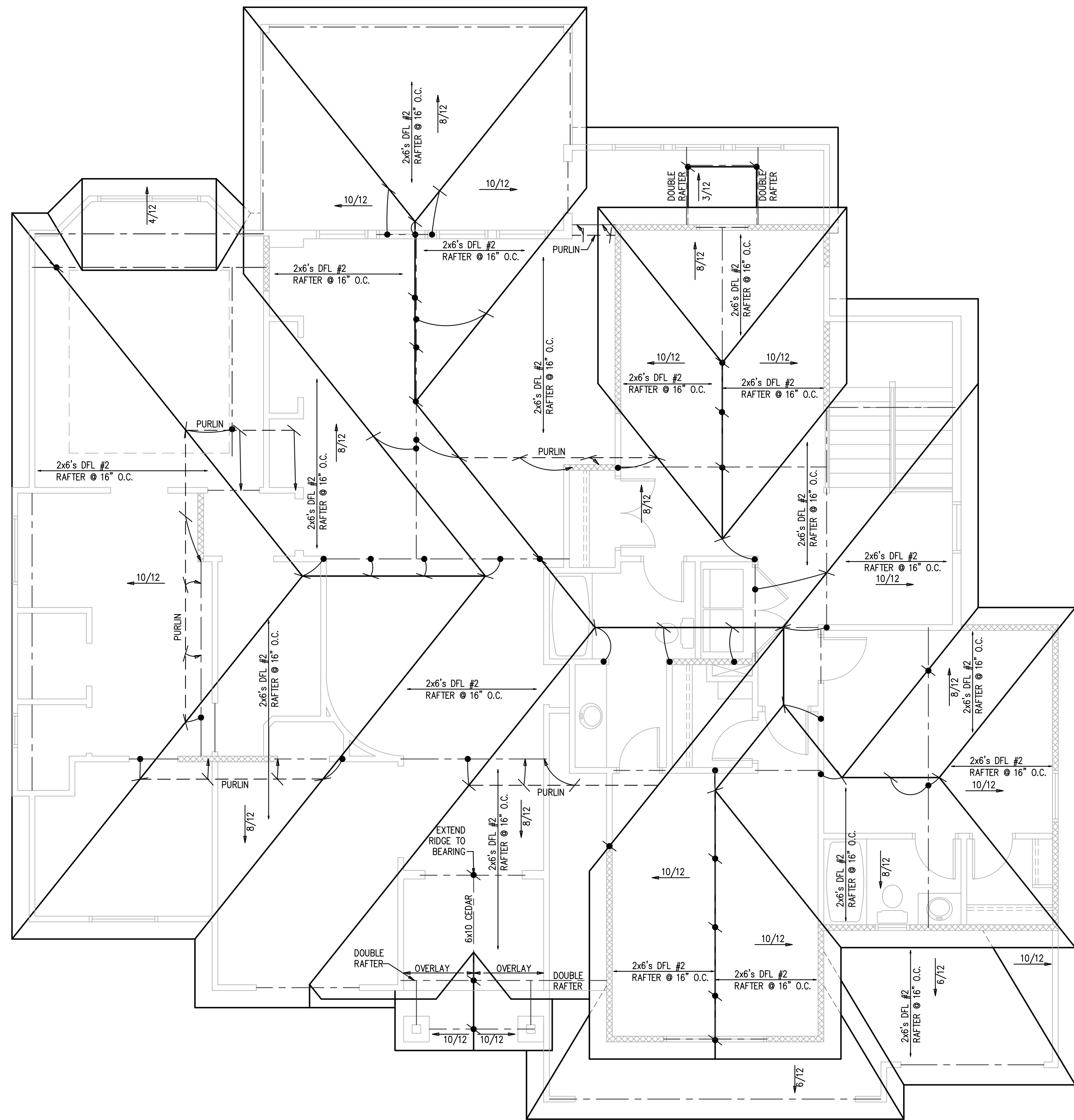

ROOF PLAN
SCALE: 1/4" = 1'-0"

STRUCTURAL NOTES:
 - ALL UNMARKED HEADERS MIN (2)#2-2x10
 - ALL HEADERS AND BEAMS MIN #2 GRADE DFL (OR EQ.)
 - [XXXXXX] = BEARING WALL
 - STRUCTURE NOTED AS FLUSH TO BE FLUSH WITH SUB-FLOOR ABOVE.

ROOF FRAMING NOTES
 ROOF DESIGNED FOR LIGHT ROOF COVERING
 30psf TOTAL LOAD [10psf DL, 20psf LL (SL)]
 ROOF SYSTEM IS DESIGNED TO MEET REQUIREMENTS OF IRC 802

*RAFTERS (HEM-FIR, DOUG-FIR, OR EQUAL):
 SEE SPAN CHARTS BELOW

CODE MINIMUM

RAFTERS	SPACING	MAX HORIZONTAL CLEARSPAN
#2-2x6	AT 24" OC	11'-7"
#2-2x6	AT 16" OC	14'-2"
#2-2x8	AT 24" OC	14'-8"
#2-2x8	AT 16" OC	17'-11"
#2-2x10	AT 24" OC	17'-10"
#2-2x10	AT 16" OC	21'-11"

NOTE: CODE MINIMUM ALLOWS FOR A RAFTER DEFLECTION OF L/180 TOTAL LOAD

HIGHER PERFORMANCE

RAFTERS	SPACING	MAX HORIZONTAL CLEARSPAN
#2-2x6	AT 24" OC	8'-6"
#2-2x6	AT 16" OC	9'-9"
#2-2x8	AT 24" OC	11'-3"
#2-2x8	AT 16" OC	12'-9"
#2-2x10	AT 24" OC	14'-3"
#2-2x10	AT 16" OC	16'-3"

APEX ENGINEERS, INC. RECOMMENDED DEFLECTION = L/360 LIVE LOAD, L/240 TOTAL LOAD

- *RIDGE BOARDS ARE (UNLESS OTHERWISE NOTED) #2-2x10 UP TO 9:12 PITCH #2-2x12 OVER 9:12 PITCH
- *ALL HIP AND VALLEYS ARE (UNLESS OTHERWISE NOTED) #2-2x10 UP TO 9:12 PITCH #2-2x12 OVER 9:12 PITCH #2-2x10 HIP/VALLEY, MAX CLEAR SPAN: 11'-11" #2-2x12 HIP VALLEY, MAX HORIZ. CLEAR SPAN: 12'-11"
- *PURLINS ARE 2x6 MIN
 - PURLIN STRUTS ARE AT 4'-0" OC
 - PURLIN STRUTS SHALL BE INSTALLED AT NOT LESS THAN A 45 DEGREE ANGLE WITH THE HORIZONTAL
 - ALL PURLIN STRUTS SHALL HAVE A MAX UNBRACED LENGTH OF 8'-0"
 - PURLIN STRUTS SHALL BE CONSTRUCTED IN A "T" CONFIGURATION AND PER THE FOLLOWING CHART:

PURLIN STRUT	MAX PURLIN STRUT LENGTH
(2)2x4	8'-0"
(1)2x4 AND (1)2x6	12'-0"
(1)2x6 AND (1)2x8	20'-0"
(2)2x6 AND (1)2x8	30'-0"
CONSULT ARCH ENGR	>30'-0"

- *EACH END OF STRUT SHALL BE FASTENED WITH MIN (3)#8 OR (2)#10 NAILS
- *RIDGE BRACERS ARE SAME AS PURLIN BRACES-SPACING, SIZE, CONFIGURATION, AND INSTALLATION (SEE PURLIN BRACE NOTES ABOVE)
- *HIP AND VALLEY BRACES ARE THE SAME AS PURLINS SIZE, CONFIGURATION, AND INSTALLATION (SEE PURLIN BRACE NOTES ABOVE)

- = ROOF BRACE/STRUT (PER CHART)
 - SLASH IS TOP END OF BRACE
 - CIRCLE IS BOTTOM END OF BRACE
- = PURLIN STRUTS AT 48" OC (PER CHART) U.N.O.
 - SLASH IS TOP END OF BRACE
 - ARROW IS BEARING LOCATION

- [XXXXXX] DENOTES BEARING WALL
- - - - - DENOTES PURLIN
- - - - - DENOTES BEARING STRUCTURE

- THIS IS AN ENGINEERED ROOF STRUCTURE DESIGNED FOR COMPLIANCE WITH IRC 802.3, BUILD AS SHOWN WITH NO DEVIATIONS.**
- ALL HIPs ARE DESIGNED TO BE CONTROLLED BY BENDING.**
- SHEAR AT BEARING WITH MIN 5 1/2" DEPTH DOES NOT CONTROL DESIGN. FOR VALLEYS REF 4/S3.2**

New Mark Homes
 P.O. Box 12025
 Parkville, Missouri 64152
 Ph. (816) 969-9010

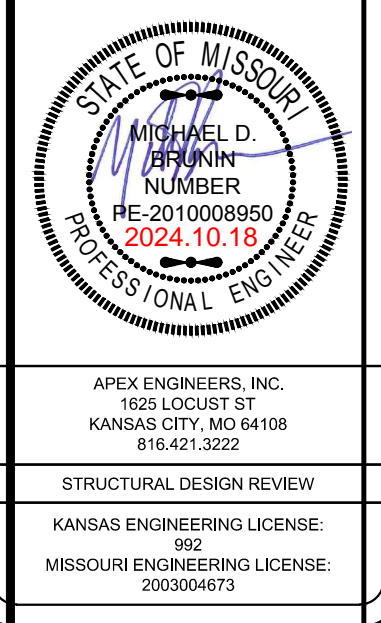

The Hilmer Residence
 2805 SW Heathstone Pl - Hook Farms - Lot 81
 Lees Summit, Missouri
 Copyright 2024

DRAWN BY: CJD
 CHECKED BY: CA
 DATE: 10/16/2024

A5
 RELEASE FOR CONSTRUCTION
 AS NOTED PLAN REVIEW
 DEVELOPMENT SERVICES
 LEES SUMMIT, MISSOURI
 PROJECT: 11/07/2024

NOTE:
 PLANS DESIGNED PER IRC AS
 ADOPTED BY GOVERNING JURISDICTION

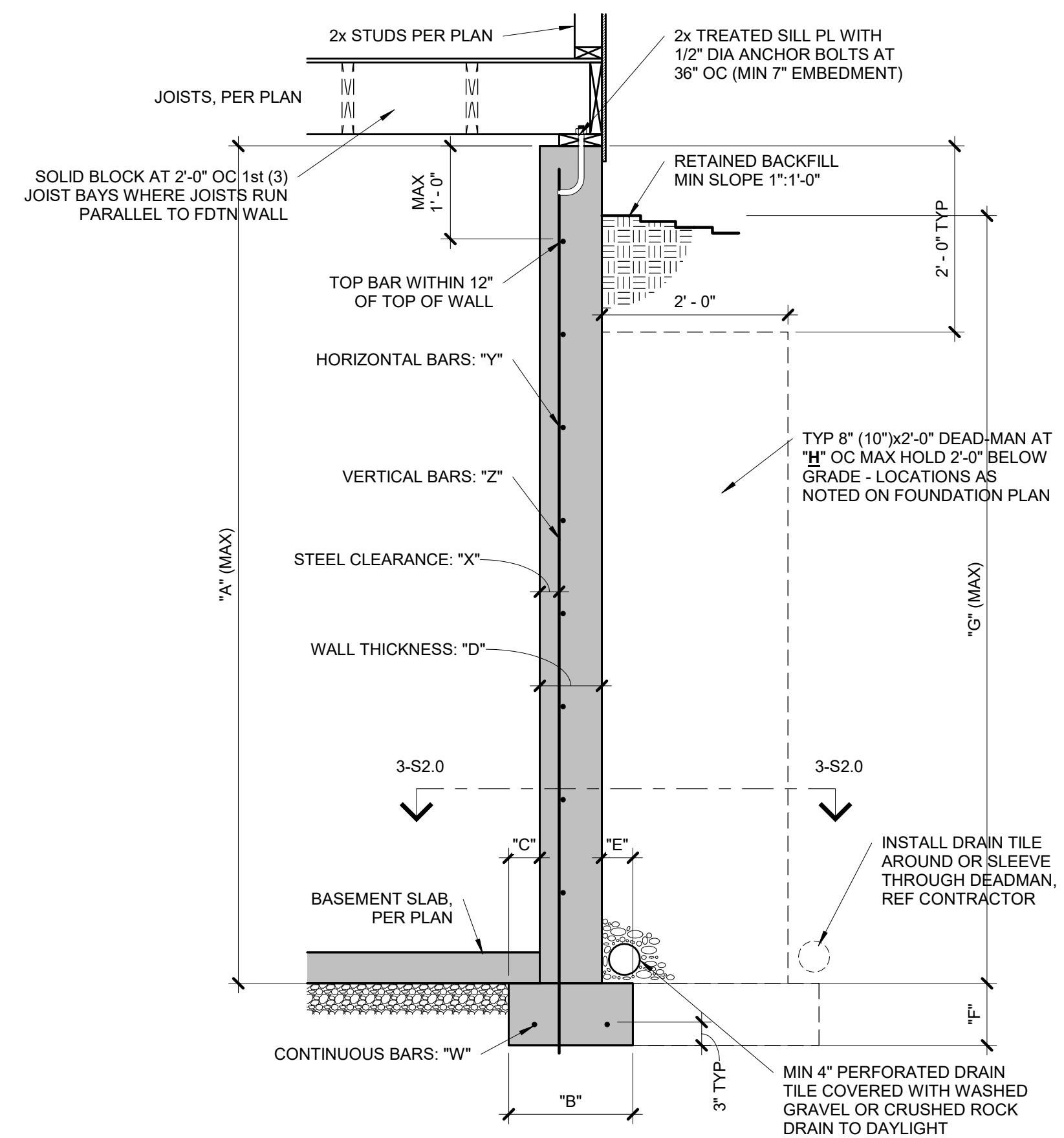

CONCRETE DIMENSIONS

"A"	"B"	"C"	"D"	"E"	"F"	"G"	"H"
8'-0"	1'-4"	4"	8"	4"	8"	7'-6"	20'-0"
9'-0"	1'-4"	4"	8"	4"	8"	8'-6"	20'-0"
10'-0"	1'-8"	5"	10"	5"	10"	9'-6"	20'-0"

REINFORCING BARS (GRADE 40 BARS)

"W"	"X"	"Y"	"Z"
(2) #4	2 1/2"	#4 BARS AT 24" OC	#4 BARS AT 24" OC
(2) #4	2 1/2"	#4 BARS AT 24" OC	#4 BARS AT 24" OC
(2) #4	2 1/2"	#4 BARS AT 18" OC	#4 BARS AT 18" OC

- NOTES:
- DIMENSION SHOWN IS FOR MAXIMUM UNINTERRUPTED WALL PANEL LENGTH BEFORE A DEAD-MAN SHALL BE INSTALLED. NOTE: A MINIMUM 2'-0" RETURN OR OFFSET IN THE FOUNDATION WALL SHALL SUBSTITUTE AS A DEAD-MAN AND/OR BREAK IN THE WALL PANEL LENGTH.
 - VERTICAL REINFORCING STEEL TO EXTEND TO WITHIN 8" OF TOP WALL. MINIMUM (1) #4 HORIZONTAL BAR WITHIN 12" OF TOP AND BOTTOM OF WALL.
 - BURIED CONCRETE FOUNDATION WALLS UP TO 9'-0" TALL MAY BE 8" NOMINAL THICKNESS WITH #4 BARS AT 24" OC BOTH WAYS OVER 16"x8" CONCRETE FOOTINGS WITH (2) #4 BARS CONTINUOUS, UNLESS OTHERWISE REQUIRED BY ENGINEERING REPORT BASED ON ACTUAL SITE CONDITIONS.
 - WALL WILL NOT ACHIEVE FULL STRENGTH UNTIL FIRST FLOOR DECK AND BASEMENT SLAB HAVE BEEN PLACED.

1 TYPICAL FOUNDATION WALL DETAIL

S2.0 3/4" = 1'-0"

COLUMN AND PIER PAD SCHEDULE

COLUMN MARK	PAD SIZE	REINFORCING	COL SIZE
A	30"x30"x12"	(4) #4 BARS E-W	3" SCH 40 (3.5" OD)
B	36"x36"x12"	(4) #4 BARS E-W	3" SCH 40 (3.5" OD)
C	42"x42"x12"	(5) #4 BARS E-W	3" SCH 40 (3.5" OD)
D	48"x48"x12"	(6) #4 BARS E-W	3 1/2" SCH 40 (4" OD)
E	54"x54"x16"	(8) #4 BARS E-W	REF PLAN
F	60"x60"x16"	(10) #4 BARS E-W	REF PLAN

- NOTES:
- COLUMN AND PIER PAD SIZES SHOWN ARE FOR MAXIMUM ADJUSTABLE COLUMN HEIGHT OF 9'-1". REQUIRES SEPARATE ENGINEERED DESIGN IF GREATER THAN 9'-1" TALL. COLUMNS SIZED AS QWIK-ADJUST COLUMN, BY QUALITY WAY PRODUCTS, LLC. REFER TO SAFE LOADING CAPACITIES PER MANUF SPECS, OR SUBSTITUTION TO ANOTHER PRODUCT ONLY WITH PRIOR APPROVAL BY APEX ENGINEERS.
 - COLUMN AND PIER PAD SIZES SHOWN ARE BASED ON AN ASSUMED MINIMUM ALLOWABLE SOIL BEARING CAPACITY OF 2,000 PSF.

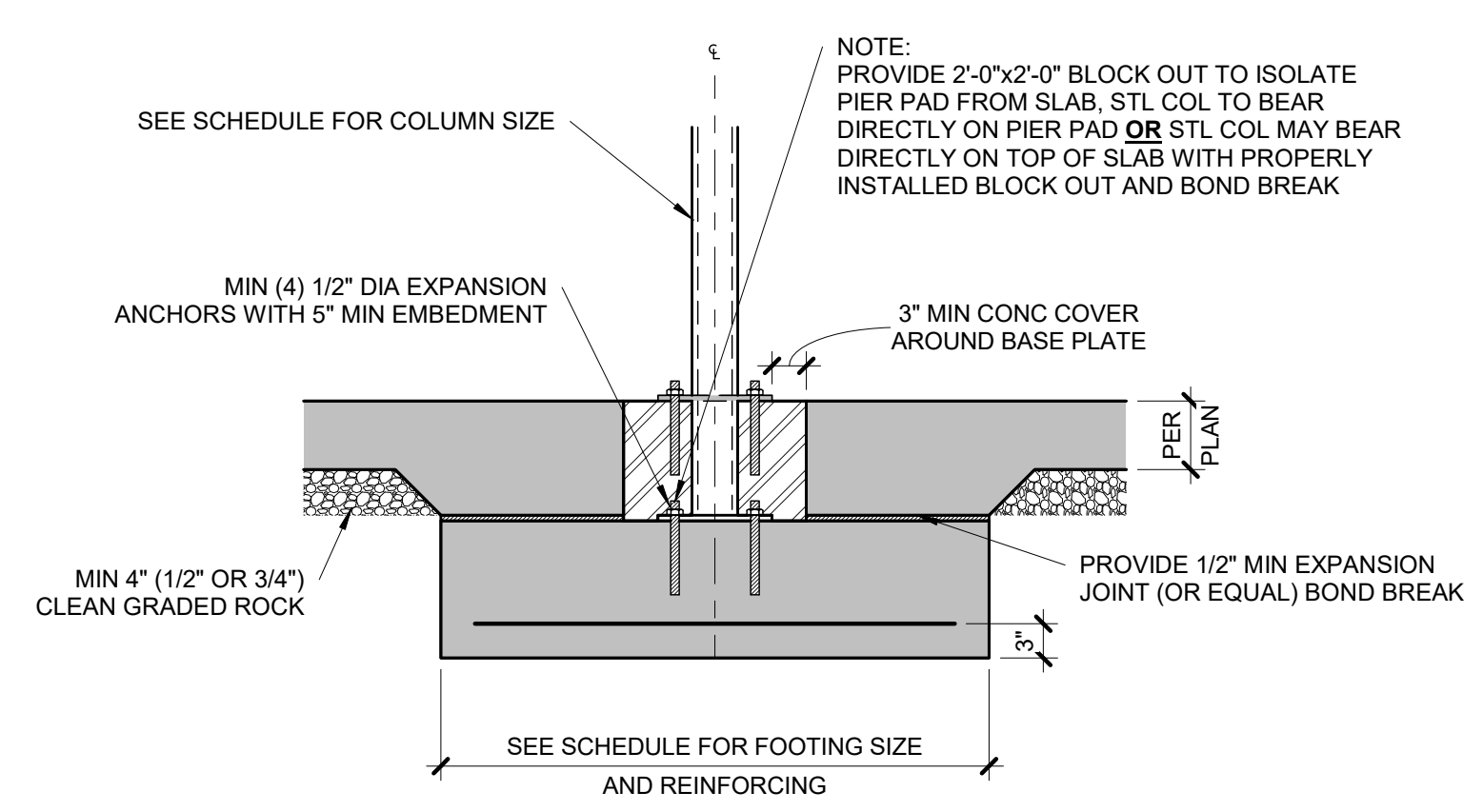

5 COLUMN PAD DETAIL

S2.0 3/4" = 1'-0"

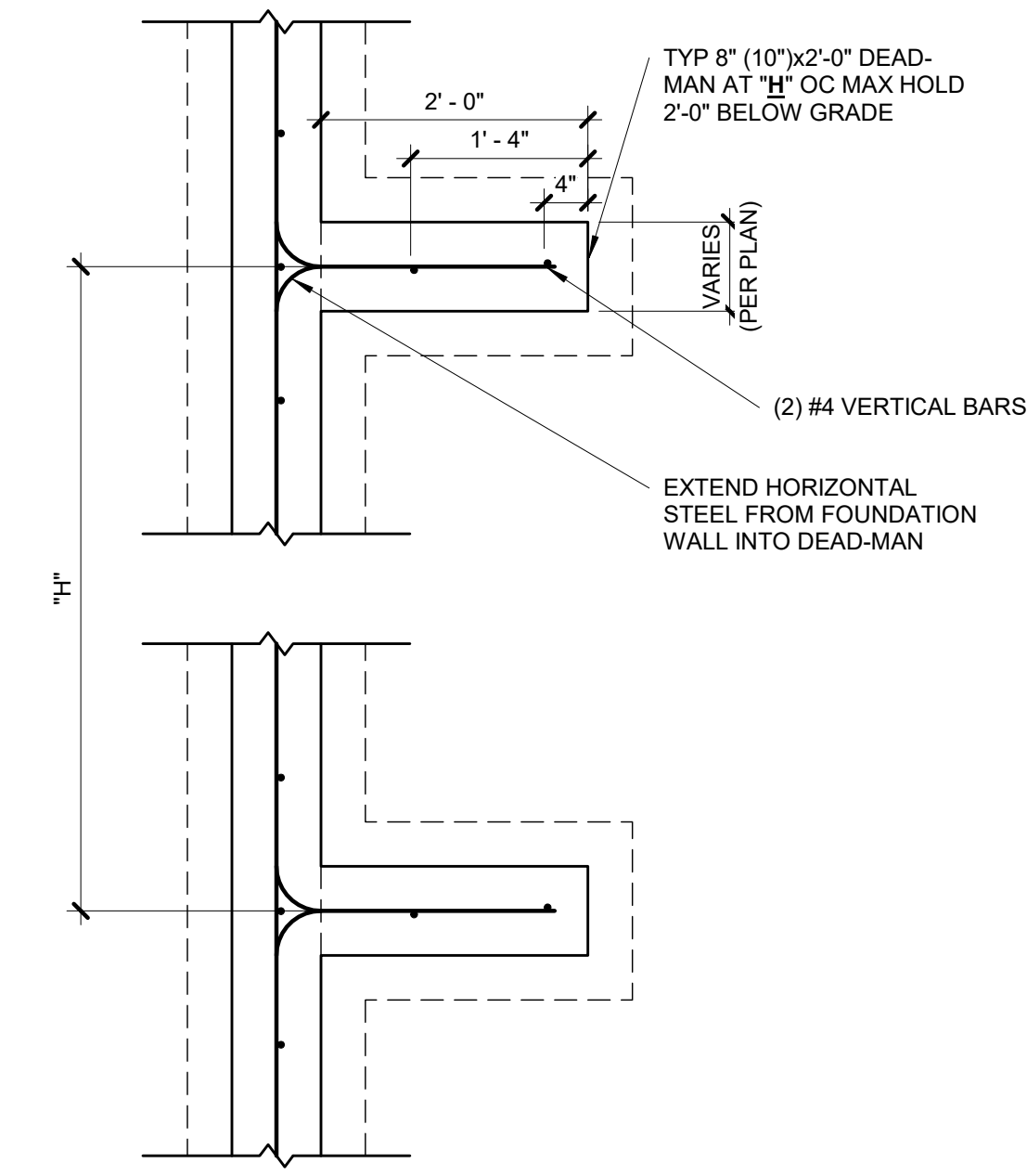

- NOTES:
- MIN 3000 PSI FOOTING COMPRESSIVE CONCRETE STRENGTH.
 - MIN 3000 PSI WALL COMPRESSIVE CONCRETE STRENGTH.
 - AIR ENTRAINMENT BETWEEN 5% & 7% OF CONCRETE VOLUME.
 - GRADE 40 REINFORCING STEEL UNLESS OTHERWISE NOTED.
 - LAP SPLICES 24" MIN.
 - WALL SHALL BE BACK-FILLED WITH CLEAN, LEAN CLAY (OR BETTER) LOW VOLUME CHANGE MATERIAL. ON-SITE MATERIAL MAY BE USED IF DEEMED ACCEPTABLE BY THE GEOTECHNICAL ENGINEER.
 - ASSUMED 2,000 PSF BEARING (TO BE VERIFIED BY GEOTECHNICAL ENGINEER).

3 TYPICAL DEAD-MAN SECTION

S2.0 3/4" = 1'-0"

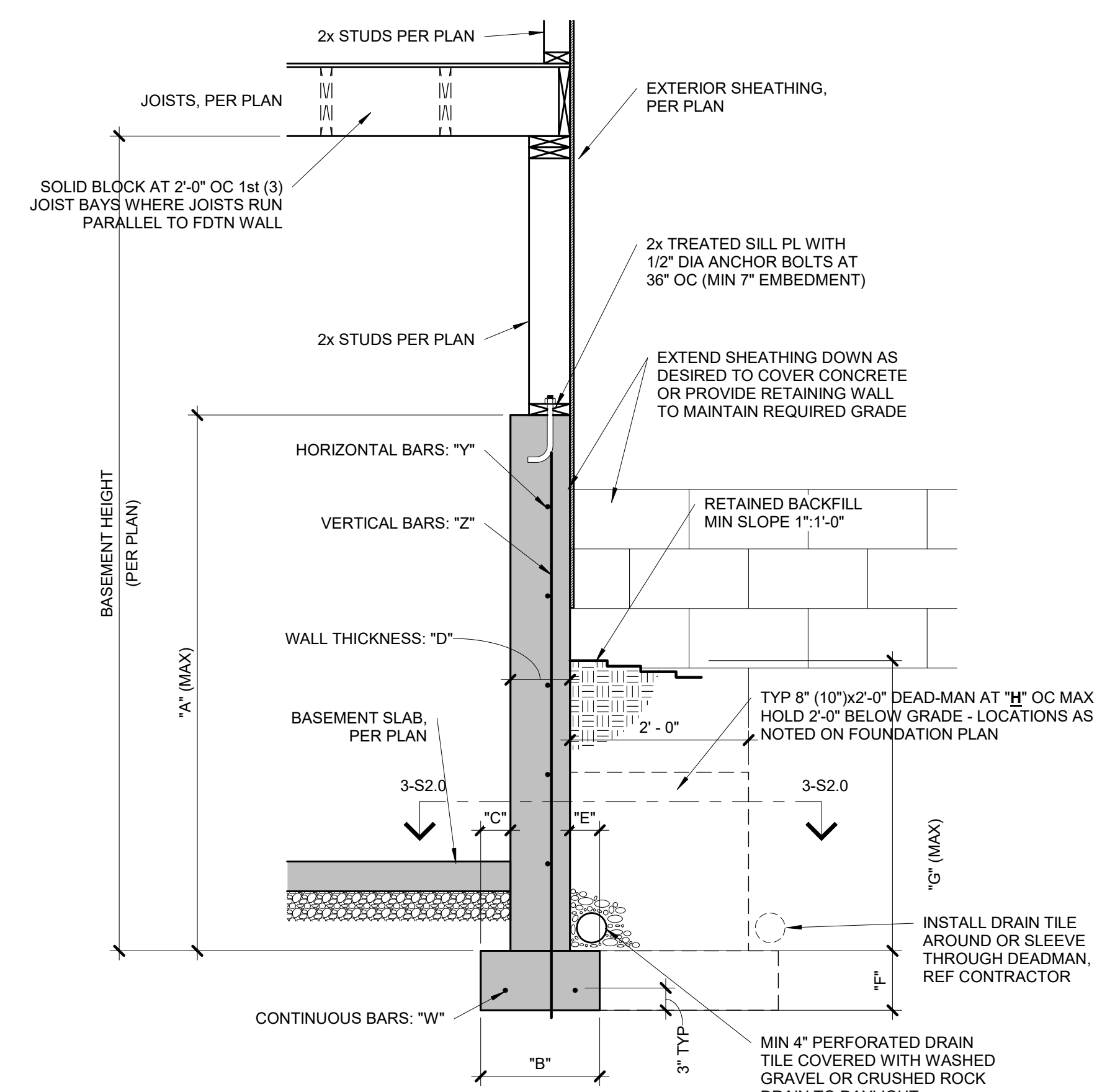

CONCRETE DIMENSIONS

"A"	"B"	"C"	"D"	"E"	"F"	"G"	"H"
4'-0"	1'-4"	4"	8"	4"	8"	3'-4"	20'-0"
6'-0"	1'-4"	4"	8"	4"	8"	4'-4"	20'-0"
9'-0"	1'-8"	5"	8"	4"	8"	4'-4"	20'-0"

REINFORCING BARS (GRADE 40 BARS)

"W"	"X"	"Y"	"Z"
(2) #4	N/A	#4 BARS AT 24" OC	#4 BARS AT 24" OC
(2) #4	N/A	#4 BARS AT 24" OC	#4 BARS AT 24" OC
(2) #4	N/A	#4 BARS AT 24" OC	#4 BARS AT 24" OC

- NOTES:
- DIMENSION SHOWN IS FOR MAXIMUM UNINTERRUPTED WALL PANEL LENGTH BEFORE A DEAD-MAN SHALL BE INSTALLED. NOTE: A MINIMUM 2'-0" RETURN OR OFFSET IN THE FOUNDATION WALL SHALL SUBSTITUTE AS A DEAD-MAN AND/OR BREAK IN THE WALL PANEL LENGTH.
 - VERTICAL REINFORCING STEEL TO EXTEND TO WITHIN 8" OF TOP WALL. MINIMUM (1) #4 HORIZONTAL BAR WITHIN 12" OF TOP AND BOTTOM OF WALL.
 - THE BASEMENT SLAB IS AN INTEGRAL PART OF THE 'UNRESTRAINED' FOUNDATION WALL DESIGN THEREFORE, IF THE WALL IS BACKFILLED PRIOR TO PLACEMENT OF THE BASEMENT SLAB, THE CONTRACTOR SHALL BE RESPONSIBLE FOR PROPERLY BRACING THE WALL UNTIL THE BASEMENT SLAB HAS BEEN PLACED.

2 TYPICAL 'UNRESTRAINED' FOUNDATION WALL DETAIL

S2.0 3/4" = 1'-0"

EXPANSIVE SOILS DISCLAIMER:

THESE PLANS HAVE BEEN PREPARED BASED ON A PRESUMPTIVE ALLOWABLE BEARING CAPACITY AS ALLOWED BY IRC CODE AND THE LOCAL ENFORCING JURISDICTION.

APEX ENGINEERS, INC. (APEX) RECOMMENDS THAT ALL FOOTING EXCAVATIONS BE EVALUATED BY A LICENSED GEOTECHNICAL ENGINEER PRIOR TO THE PLACEMENT OF ANY FOUNDATION ELEMENTS. GEOTECHNICAL INVESTIGATION AND/OR TESTING IS NOT A SERVICE PROVIDED OR OFFERED BY APEX.

APEX HAS NOT BEEN RETAINED TO DETERMINE THE EXPANSIVE SOIL CHARACTERISTICS OF THE SUBGRADE SOIL AND THEREFORE CANNOT BE HELD RESPONSIBLE FOR THE VOLUMETRIC CHANGES OF THE SOIL (INCLUDING BELOW THE BASEMENT SLAB). BY USE OF THESE PLANS WITHOUT AN ACCOMPANYING GEOTECHNICAL ENGINEERING REPORT, APEX SHALL NOT BE HELD LIABLE FOR ANY FUTURE MOVEMENT AND/OR DIFFERENTIAL MOVEMENT OF THE PROPOSED STRUCTURE AND THE POSSIBLE DAMAGE THAT MAY BE CAUSED AS A RESULT OF SUCH MOVEMENT. DAMAGE FROM EXPANSIVE SOILS AND/OR SETTLEMENT CAN RESULT IN AMONGST OTHER THINGS, THE FOLLOWING: BASEMENT SLAB HEAVE, SHEETROCK CRACKS, WINDOWS AND DOOR BECOMING OUT OF PLUMB AND STICKING AND/OR NOT OPENING, DAMAGE TO TILE, MOULDING, AND OTHER COSMETIC FINISHES.

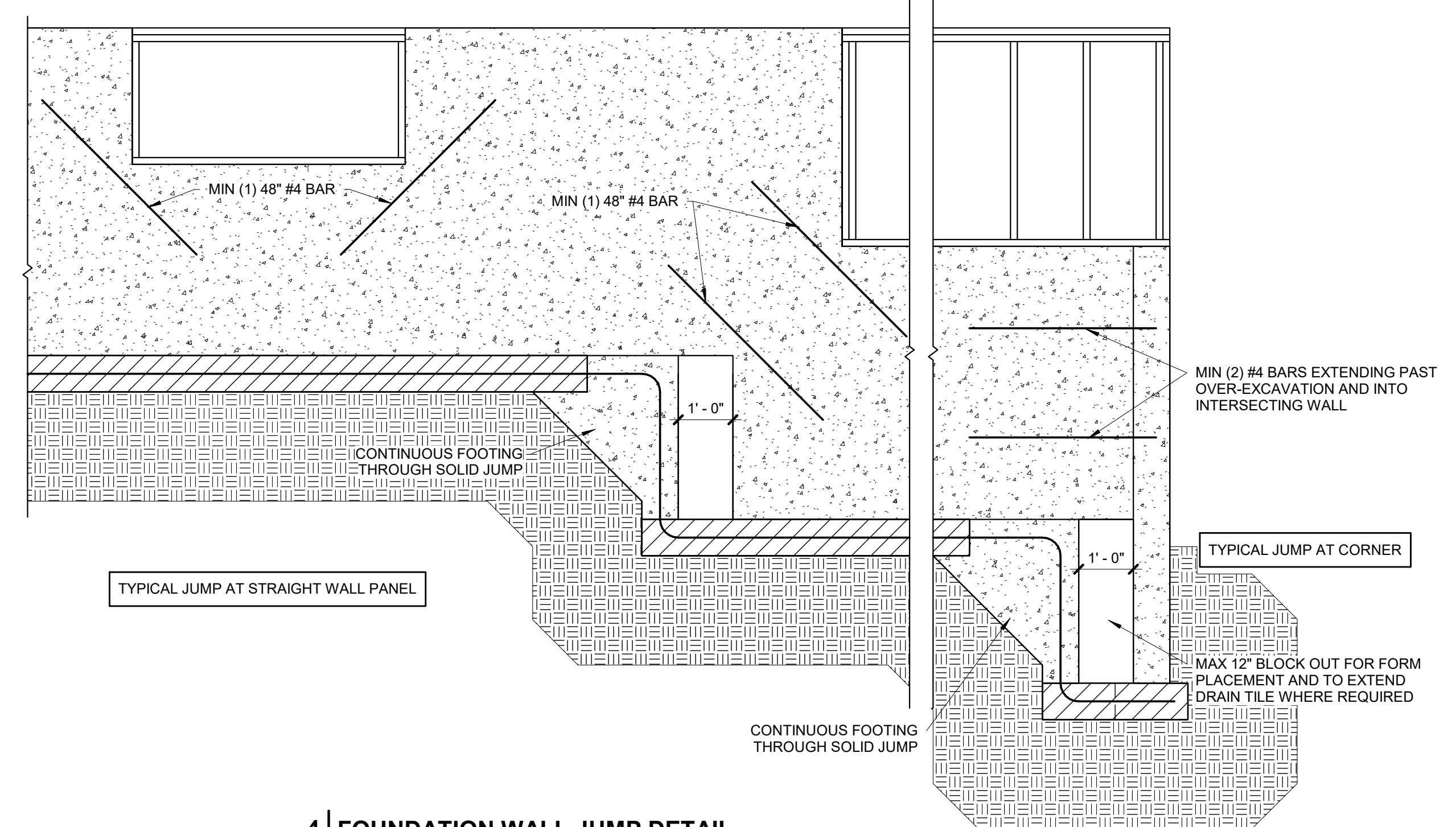

4 FOUNDATION WALL JUMP DETAIL

S2.0 1/2" = 1'-0"

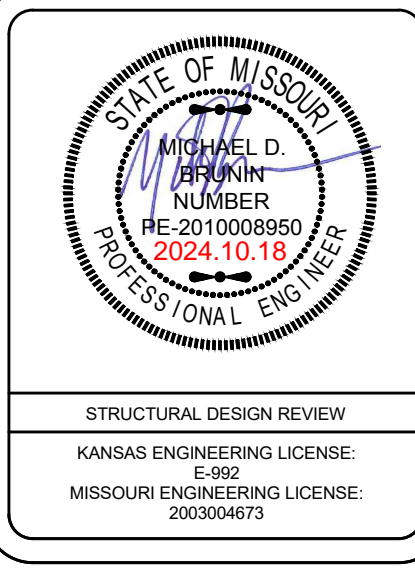

STRUCTURAL DESIGN REVIEW
KANSAS ENGINEERING LICENSE: E-592
MISSOURI ENGINEERING LICENSE: 20030673

PROJECT: Lot 81 Hook Farms, 2805 SW Heathstone Pl, Lee's Summit, MO
CLIENT: New Mark Homes

PROJECT #: 24-1710
DRAWN BY: XXX
CHECKED BY: BDC
SUBMITTAL DATE: 2024.10.18

DATE	COMMENTS

SHEET: FOUNDATION DETAILS

S2.0
11/07/2024

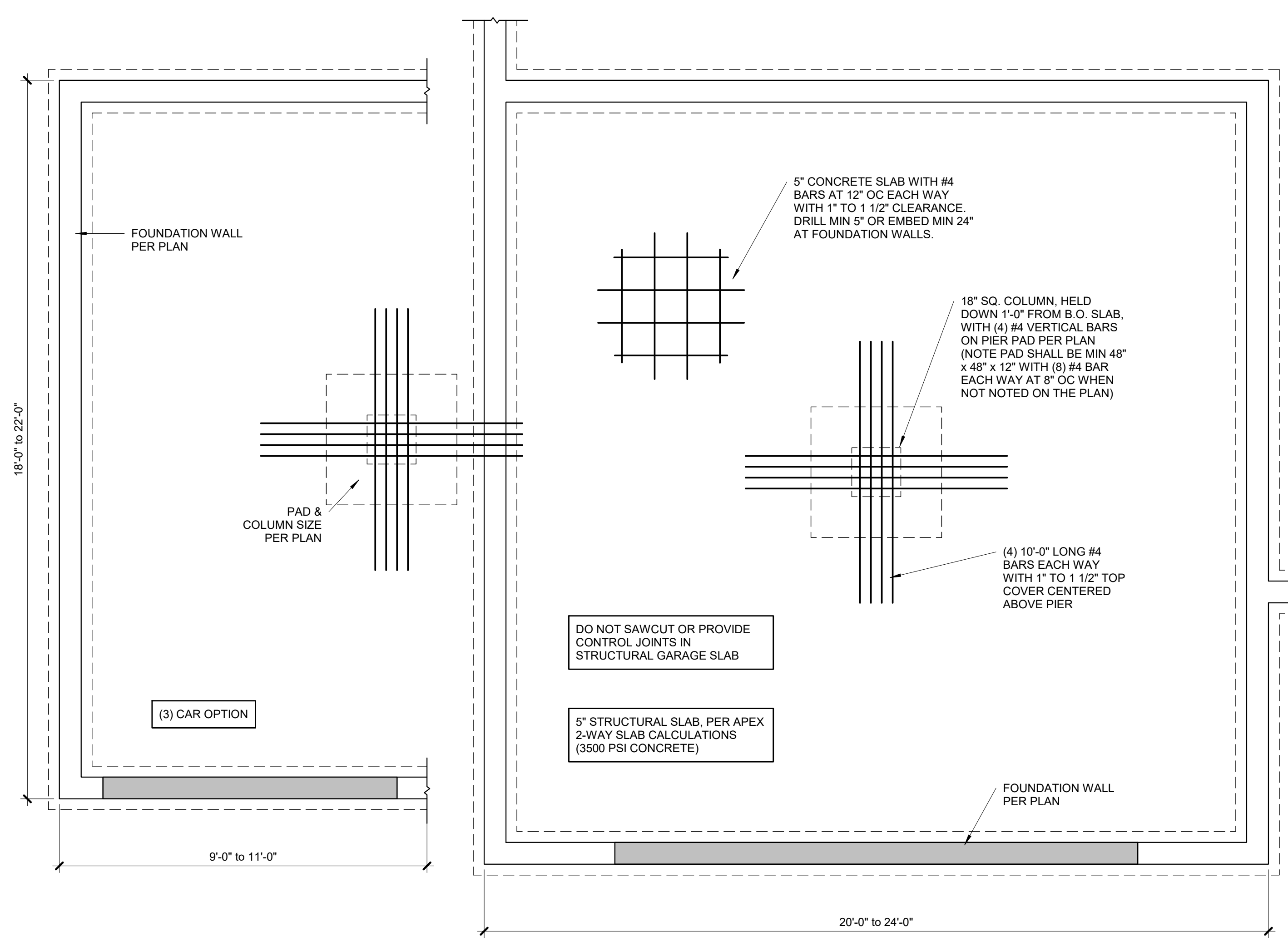

1 TYPICAL STRUCTURAL GARAGE SLAB PLAN
S2.1 3/8" = 1'-0"

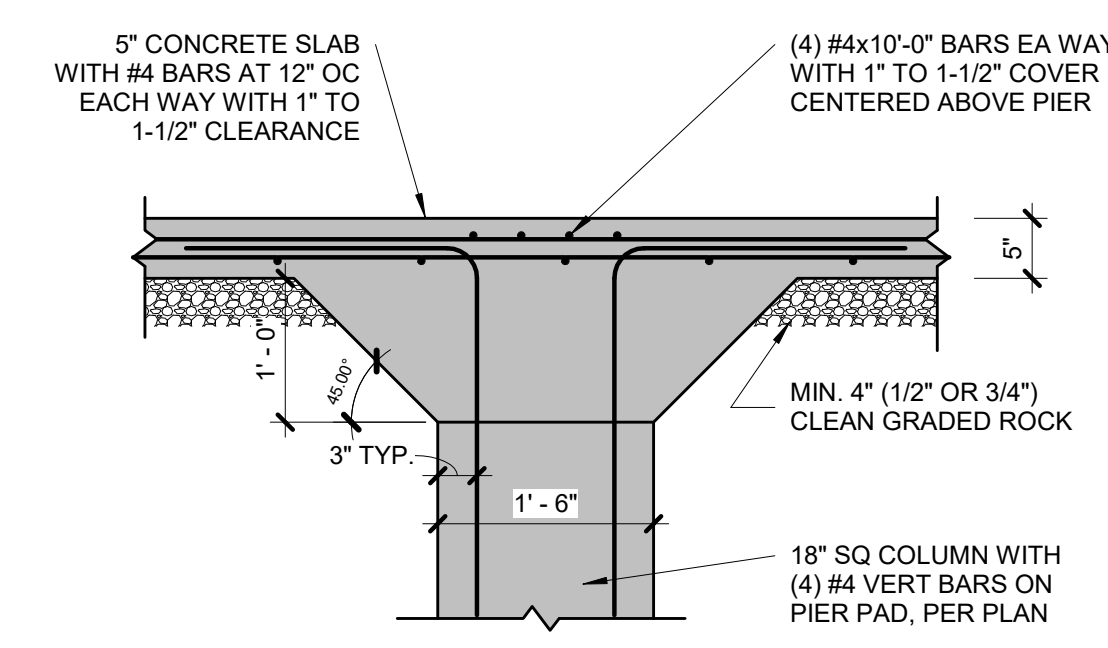

2 STRUCTURAL GARAGE SLAB PIER PAD DETAIL
S2.1 3/4" = 1'-0"

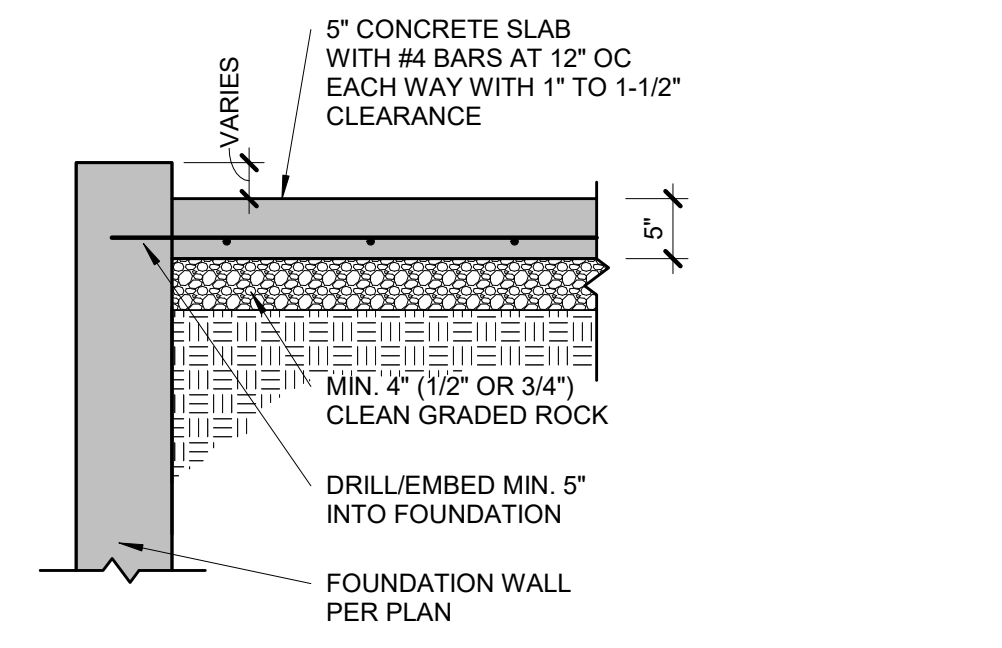

3 STRUCTURAL GARAGE SLAB/WALL SECTION
S2.1 3/4" = 1'-0"

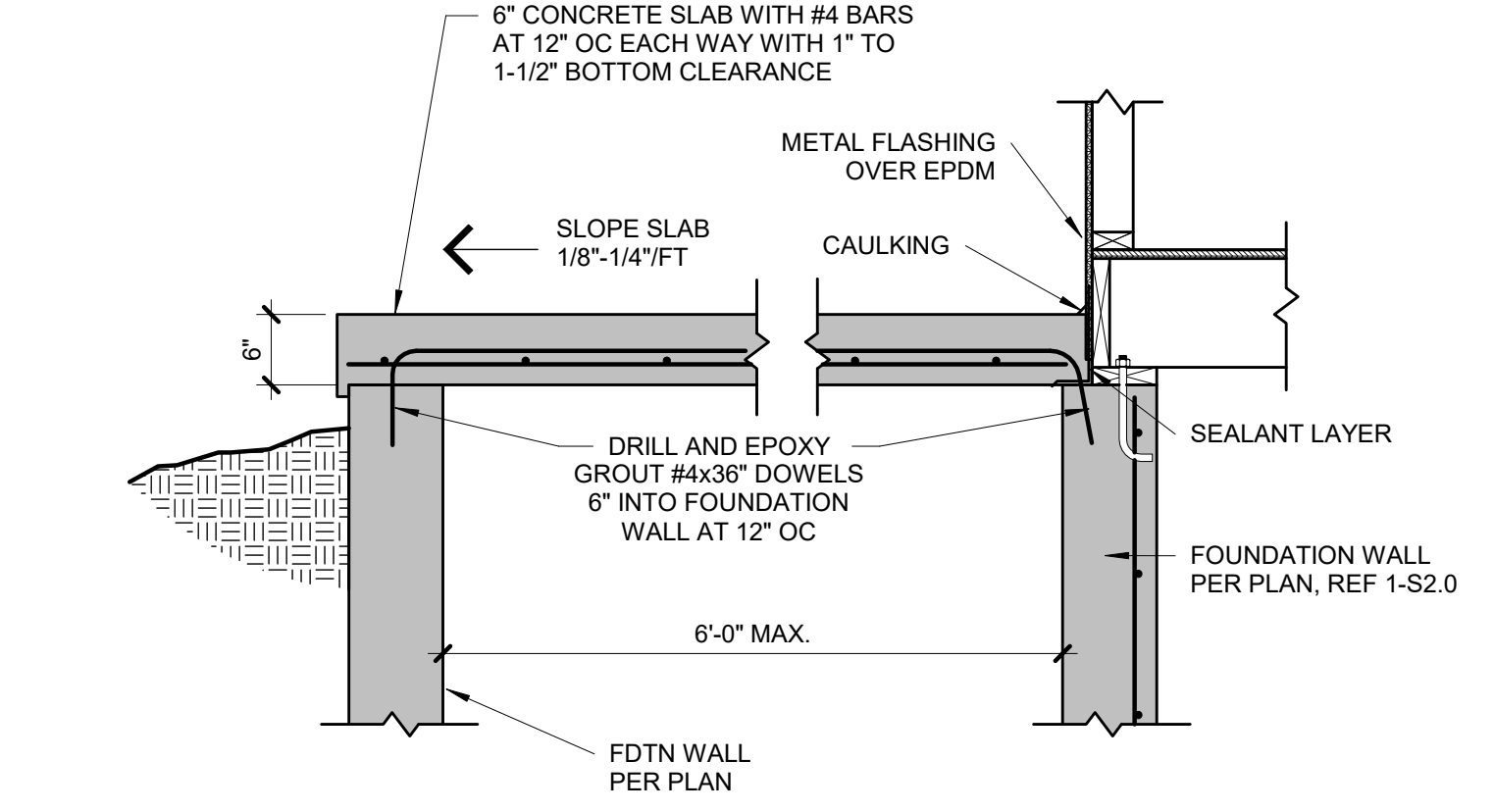

7 SUSPENDED PORCH STOOP DETAIL
S2.1 3/4" = 1'-0"

FORMWORK OPTIONS:
1. PROVIDE VULCRAFT 2VLI (OR EQUAL) CORRUGATED DECKING (SHORE AT MID-SPAN DURING CONSTRUCTION), OR
2. FLYWOOD FORMS WITH EXPANDABLE BAR JOISTS OR TEMPORARY FRAMED WALLS BY CONTRACTOR.

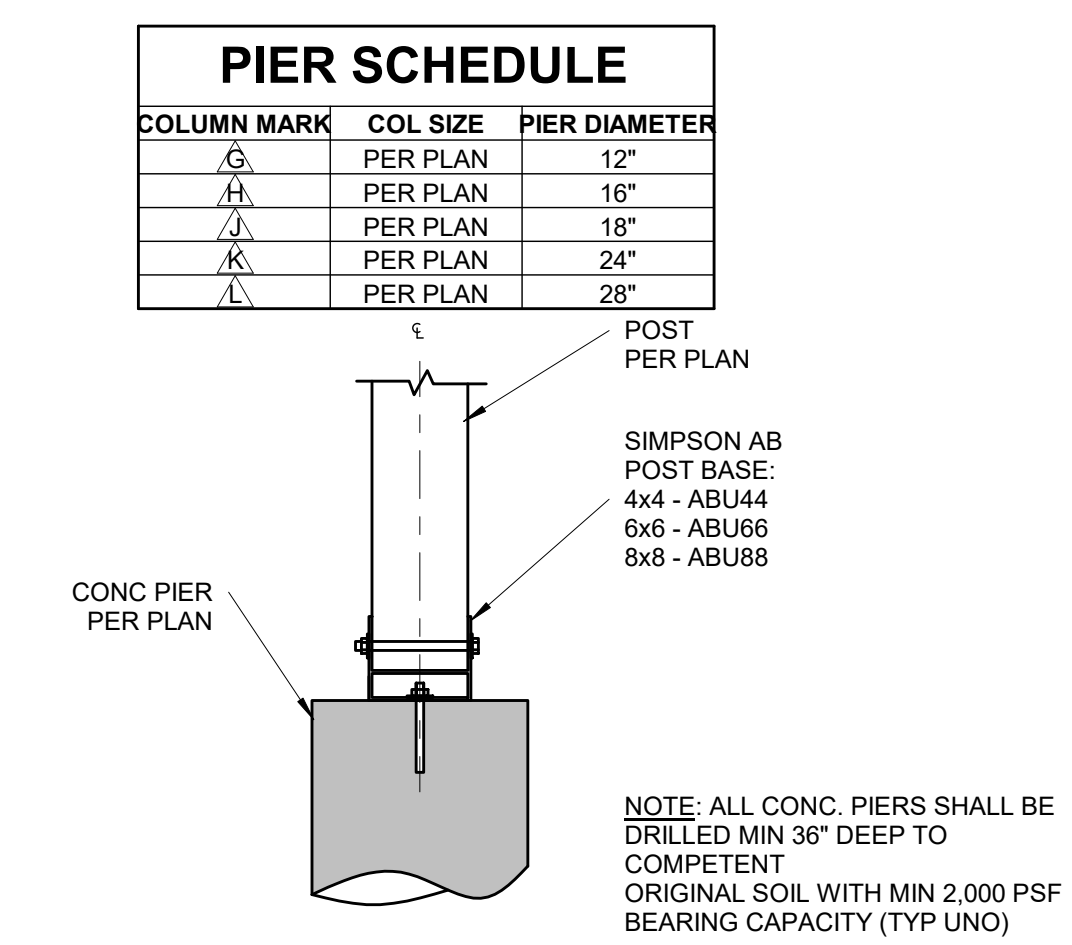

8 POST BASE DETAIL
S2.1 3/4" = 1'-0"

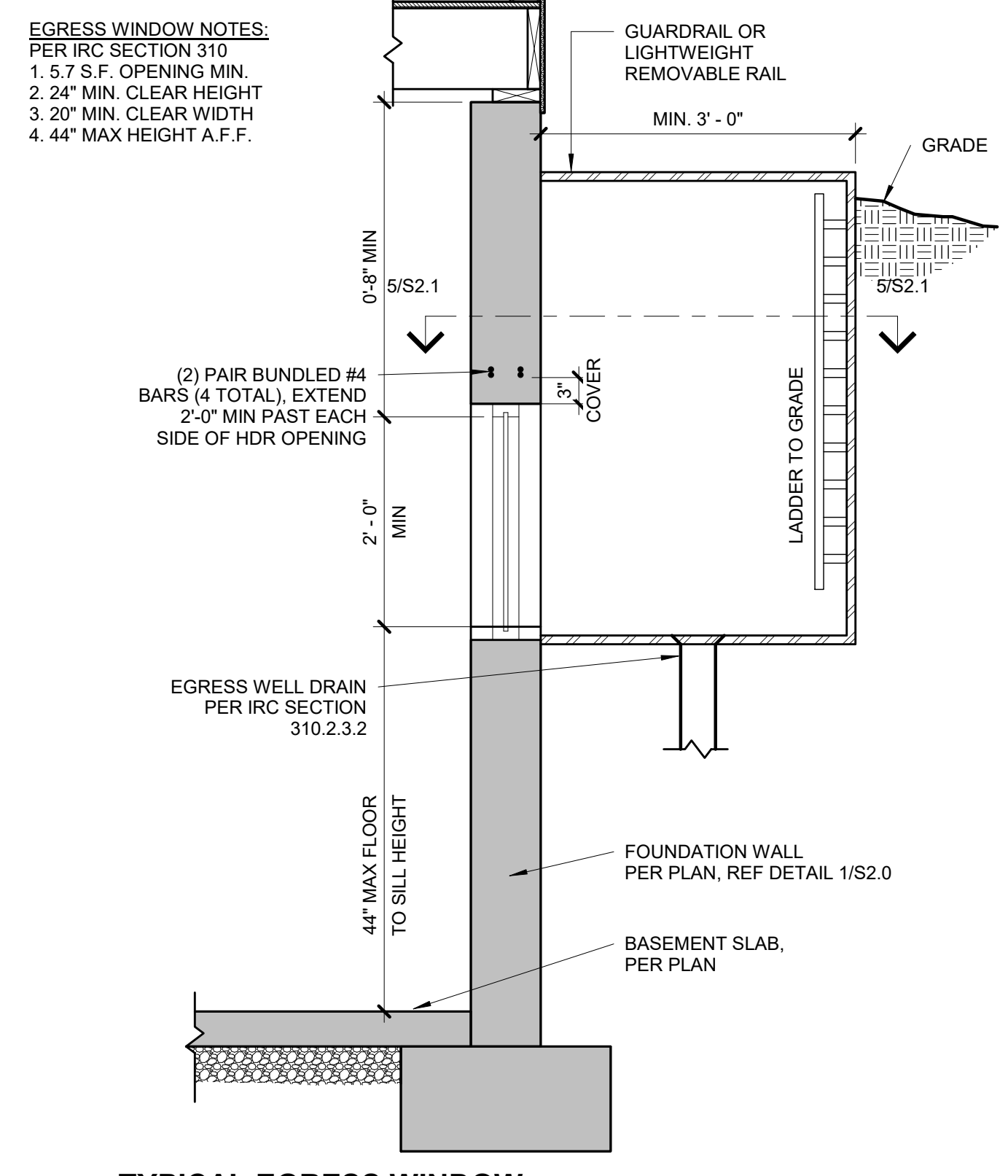

4 TYPICAL EGRESS WINDOW SECTION DETAIL
S2.1 3/4" = 1'-0"

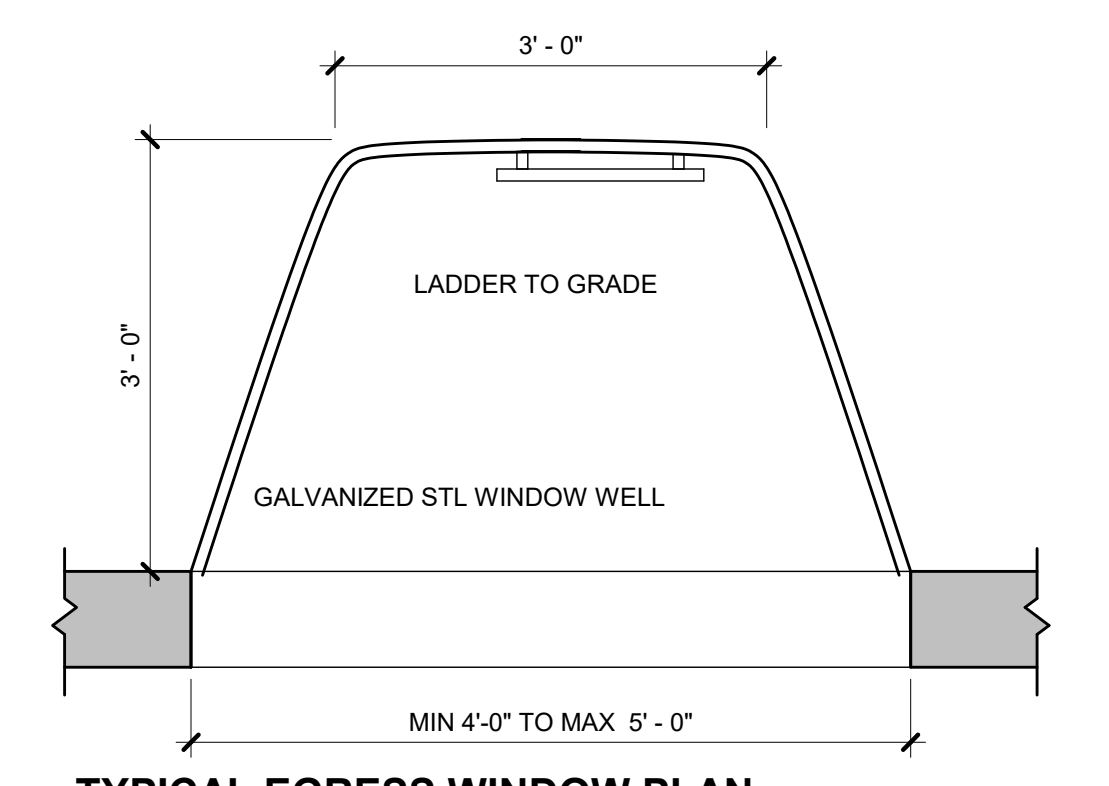

5 TYPICAL EGRESS WINDOW PLAN
S2.1 3/4" = 1'-0"

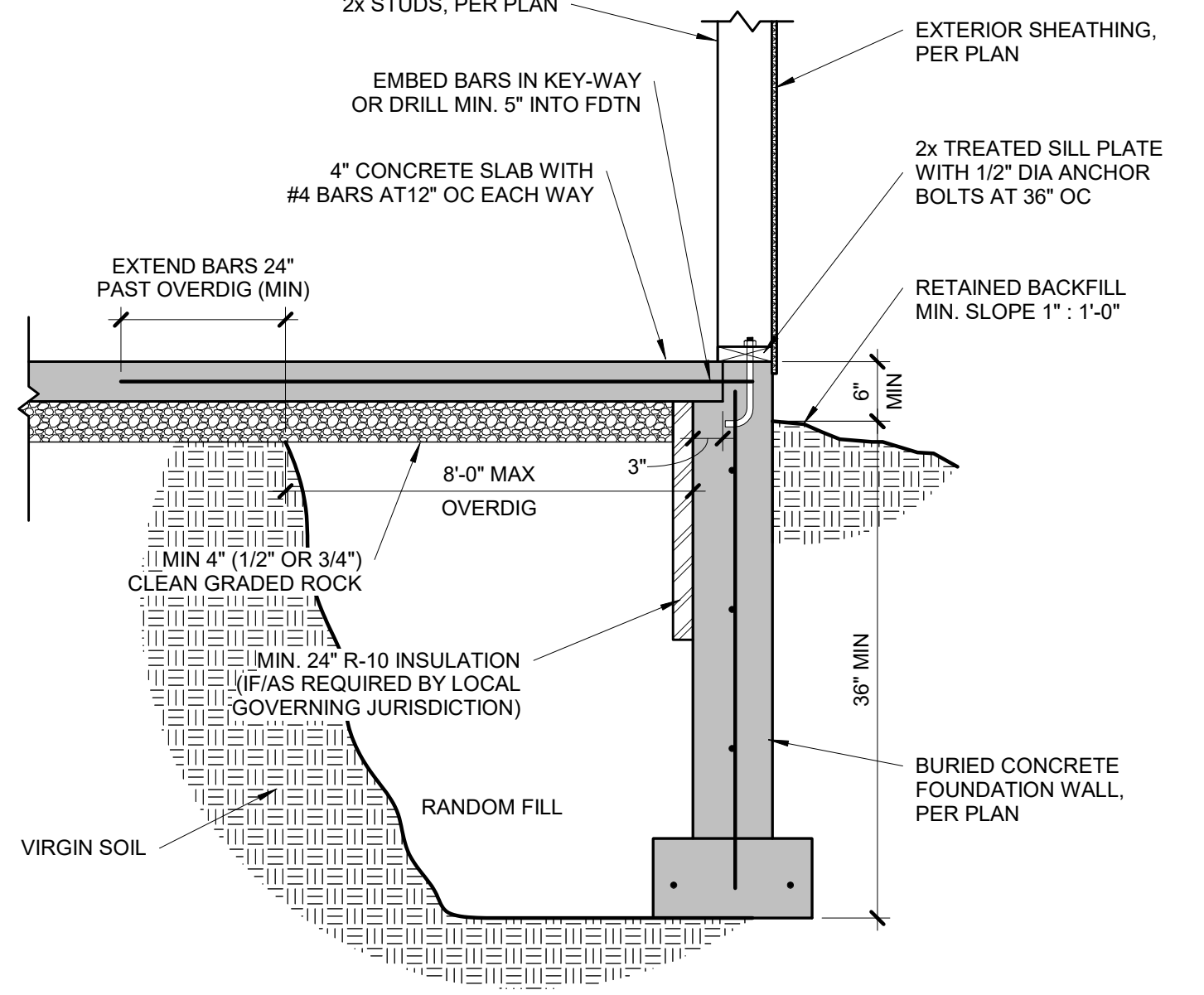

6 TYPICAL OVERDIG DETAIL AT BASEMENT SLAB
S2.1 3/4" = 1'-0"

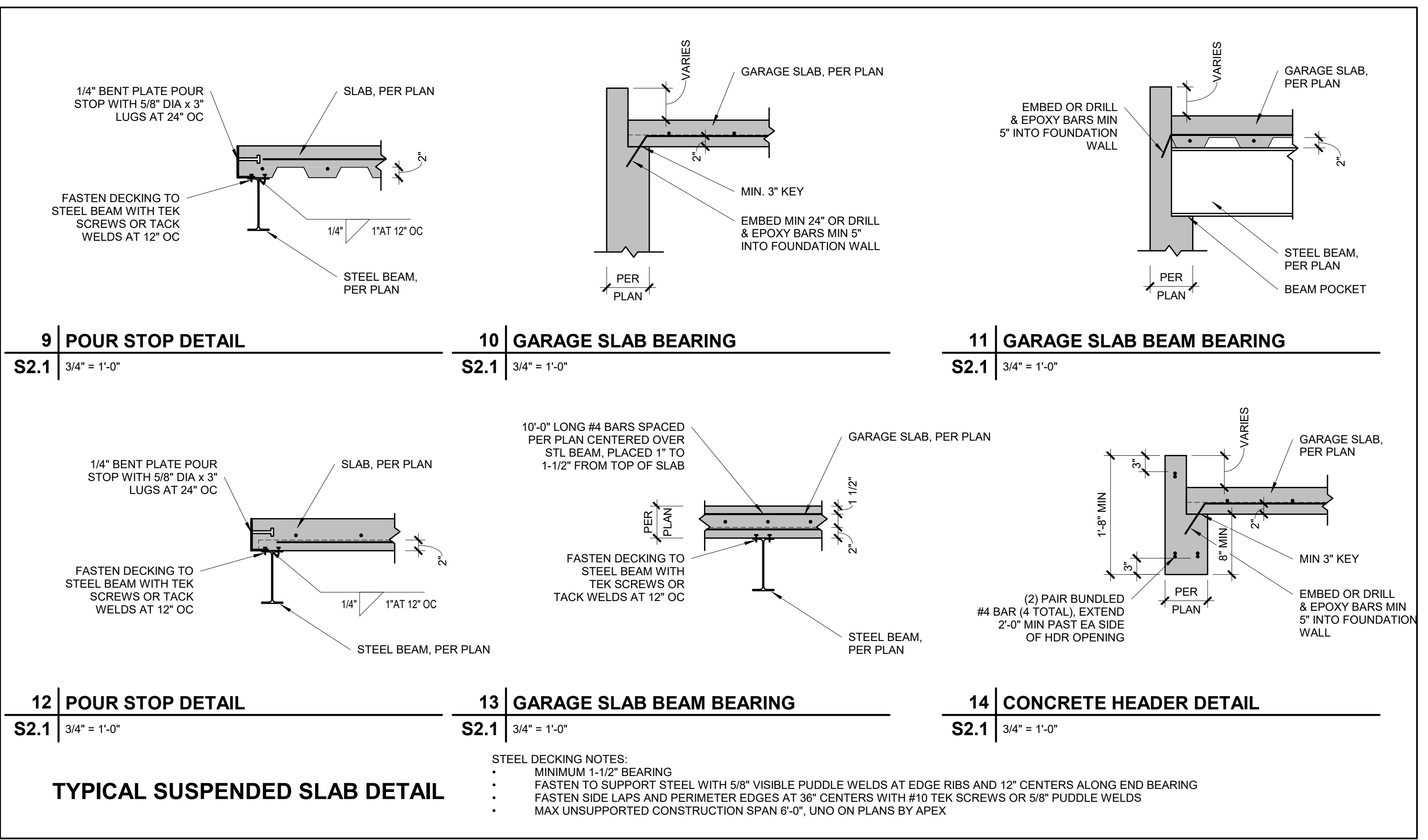

TYPICAL SUSPENDED SLAB DETAIL
S2.1 3/4" = 1'-0"

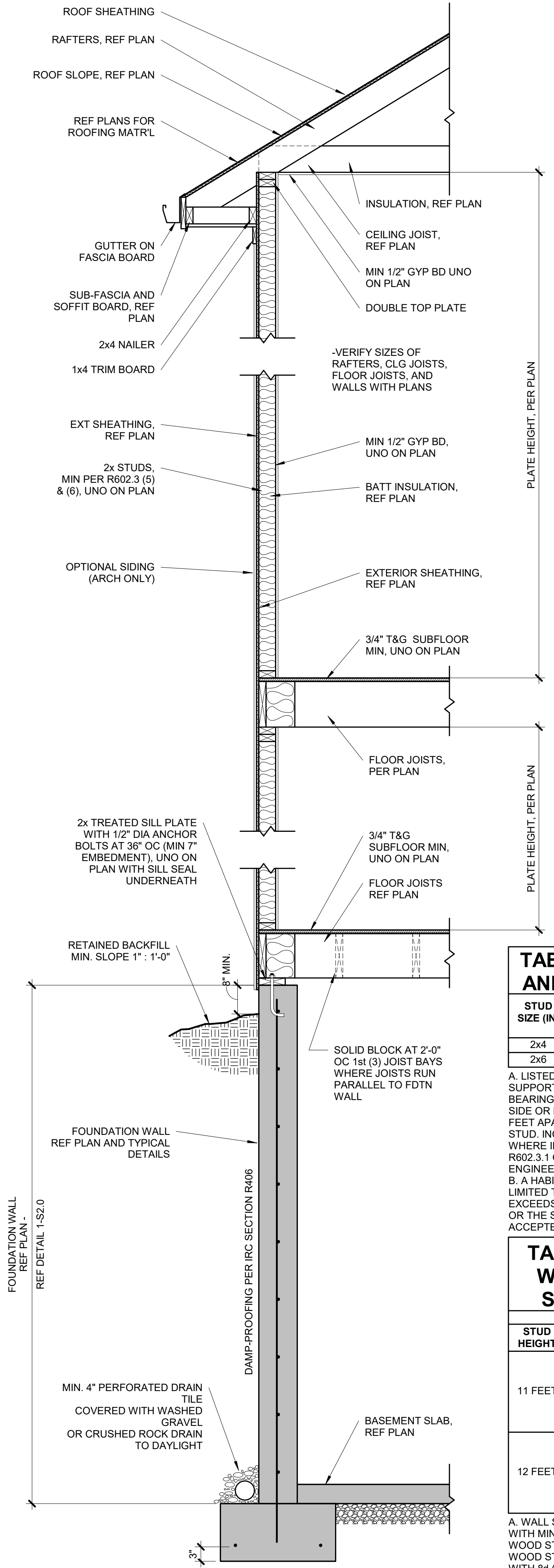

TABLE R602.3 (5) - SIZE, HEIGHT, AND SPACING OF WOOD STUDS

STUD SIZE (IN)	LATERALLY UNSUPPORTED STUD HEIGHT*	STRUCTURE SUPPORTED		
		ROOF ONLY	ROOF AND (1) FLOOR	ROOF AND (2) FLOORS
2x4	10 FEET	24" OC	16" OC	N/A
2x6	10 FEET	24" OC	24" OC	16" OC

A. LISTED HEIGHTS ARE DISTANCES BETWEEN POINTS OF LATERAL SUPPORT PLACED PERPENDICULAR TO THE PLANE OF THE WALL. BEARING WALLS SHALL BE SHEATHED ON NOT LESS THAN ONE SIDE OR BRIDGING SHALL BE INSTALLED NOT GREATER THAN 4 FEET APART MEASURED VERTICALLY FROM EITHER END OF THE STUD. INCREASES IN UNSUPPORTED HEIGHT ARE PERMITTED WHERE IN THE COMPLIANCE WITH EXCEPTION 2 OF SECTION R602.3.1 OR DESIGNED IN ACCORDANCE WITH ACCEPTED ENGINEERING PRACTICE.

B. A HABITABLE ATTIC ASSEMBLY SUPPORTED BY 2x4 STUDS IS LIMITED TO A ROOF SPAN OF 32 FEET. WHERE THE ROOF SPAN EXCEEDS 32 FEET, THE WALL STUDS SHALL BE INCREASED TO 2x6 OR THE STUDS SHALL BE DESIGNED IN ACCORDANCE WITH ACCEPTED ENGINEERING PRACTICE.

TABLE R602.3 (6) - ALTERNATE WOOD BEARING WALL STUD SIZE, HEIGHT AND SPACING

ULTIMATE DESIGN WIND SPEED = 115 MPH

STUD HEIGHT	SUPPORTING	MAX ROOF/FLOOR SPAN	
		12 FEET	24 FEET
11 FEET	ROOF ONLY	12 IN	2x4
		16 IN	2x4
	ROOF AND ONE FLOOR	24 IN	2x6
		12 IN	2x4
12 FEET	ROOF ONLY	12 IN	2x4
		16 IN	2x4
	ROOF AND ONE FLOOR	24 IN	2x6
		12 IN	2x4

A. WALL STUDS NOT EXCEEDING 16" OC SHALL BE SHEATHED WITH MINIMUM 1/2" GYPSUM BOARD ON THE INTERIOR AND 3/8" WOOD STRUCTURAL PANEL SHEATHING ON THE EXTERIOR. WOOD STRUCTURAL PANEL SHEATHING SHALL BE ATTACHED WITH 8d (2.5" x 0.131") NAILS NOT GREATER THAN 6" OC ALONG PANEL EDGES AND 12" OC AT INTERMEDIATE SUPPORTS, AND ALL PANEL JOINTS SHALL OCCUR OVER STUDS OR BLOCKING.

B. THE MAXIMUM SPAN IS APPLICABLE TO BOTH SINGLE AND MULTIPLE SPAN ROOF AND FLOOR CONDITIONS. THE ROOF ASSEMBLY SHALL NOT CONTAIN A HABITABLE ATTIC.

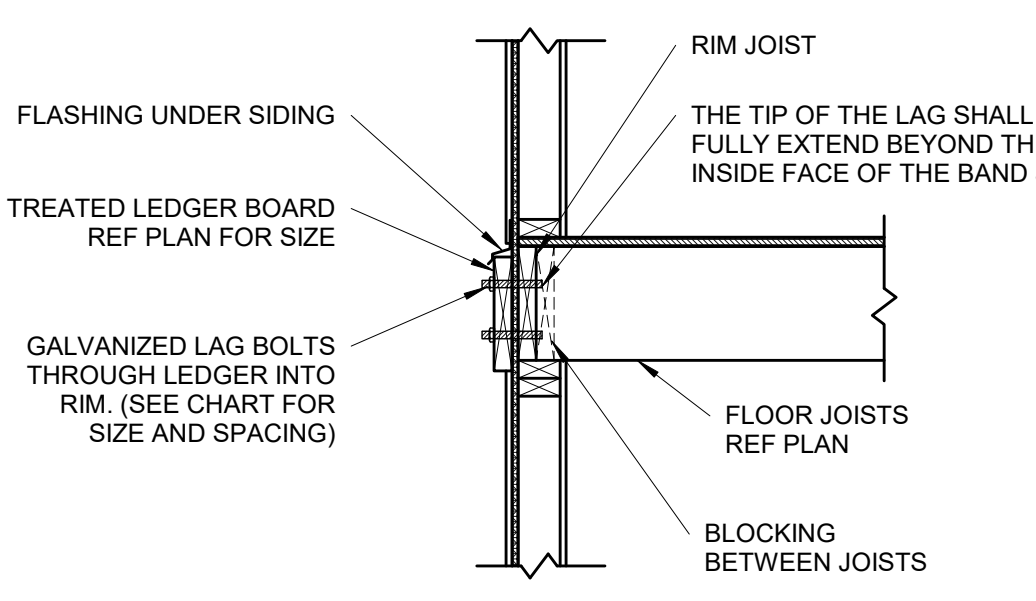
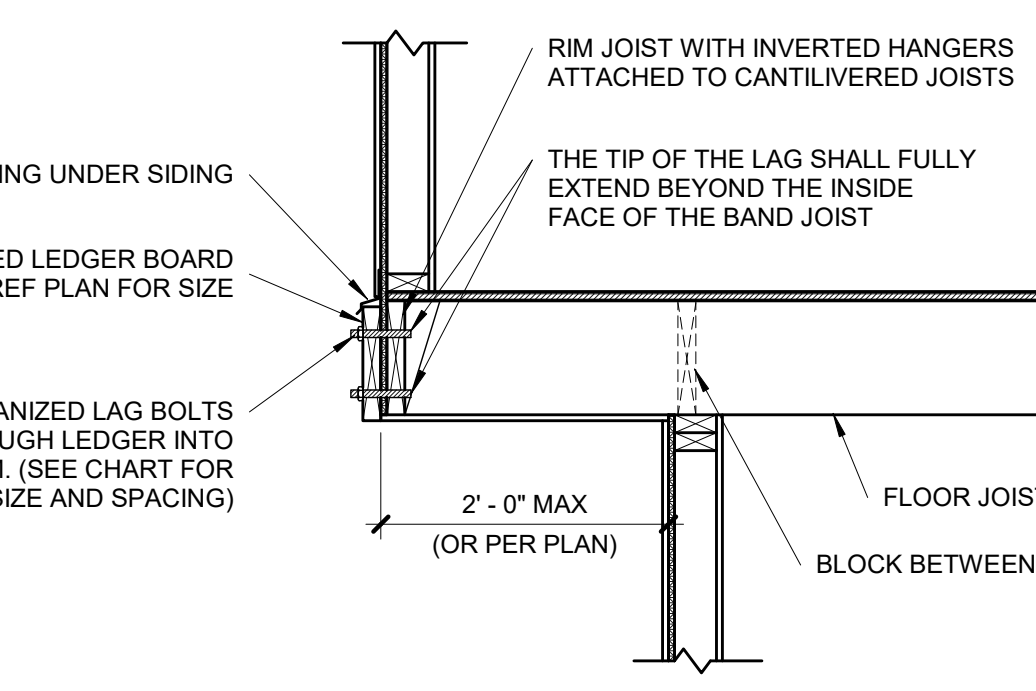
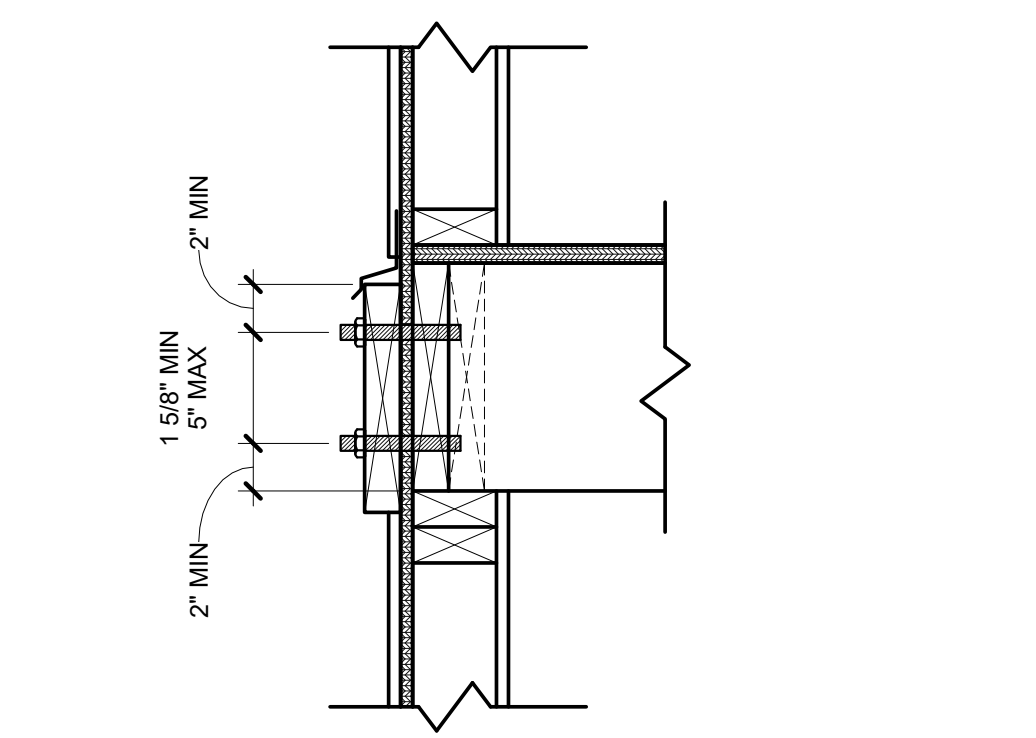
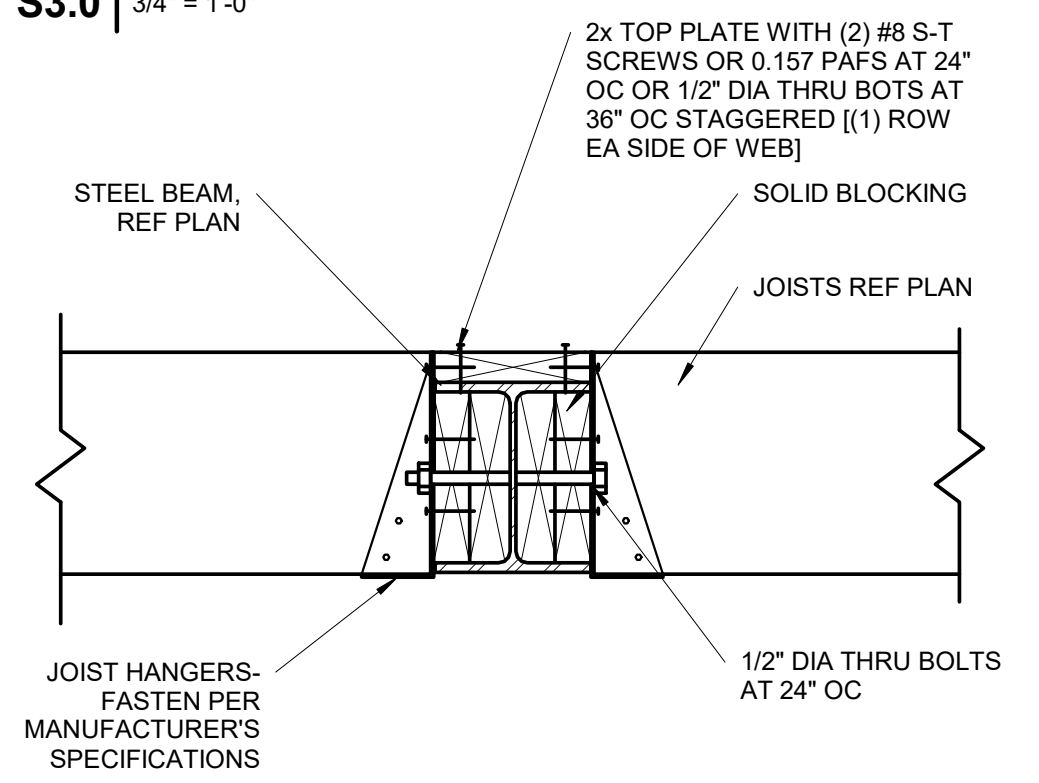
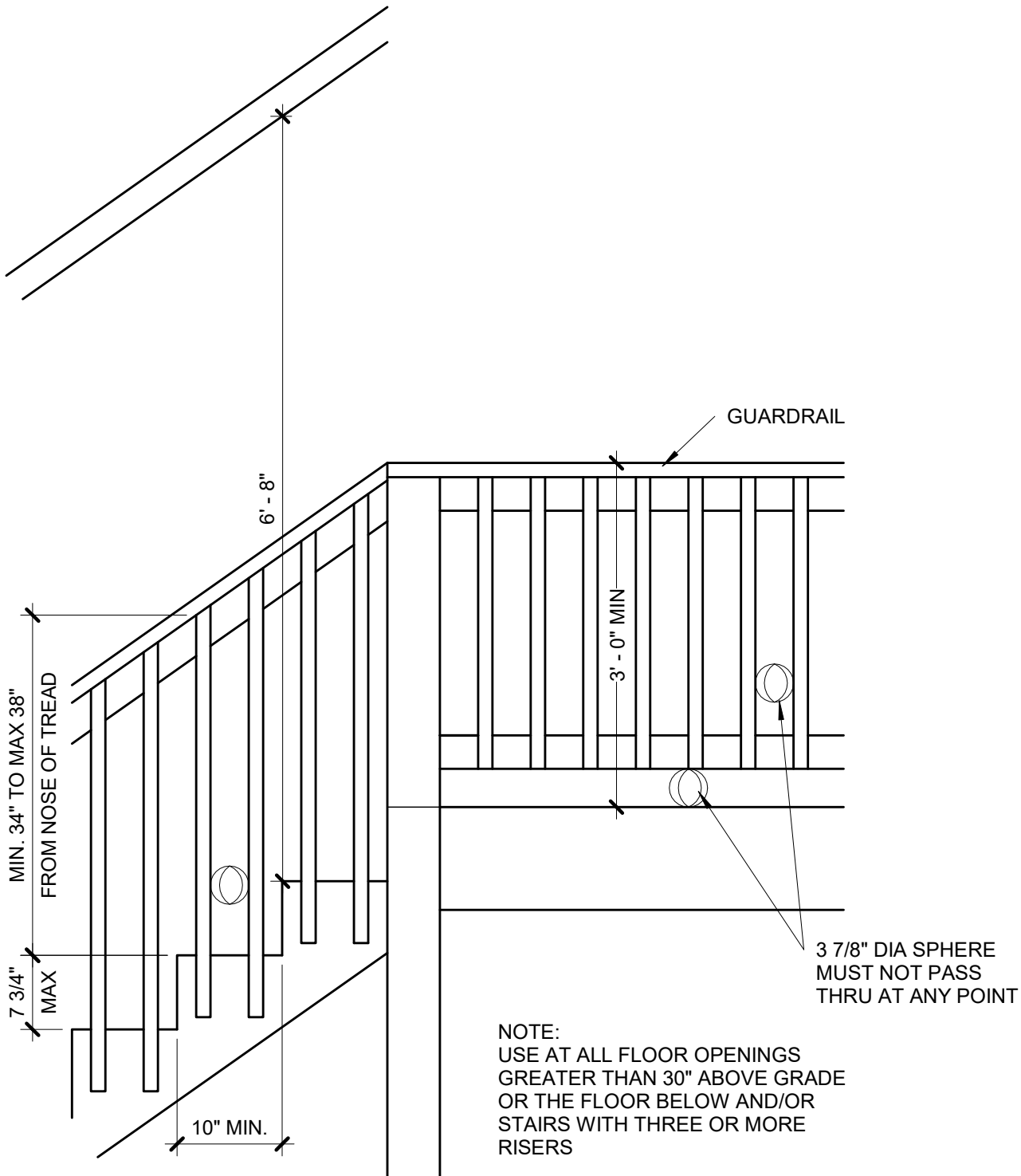
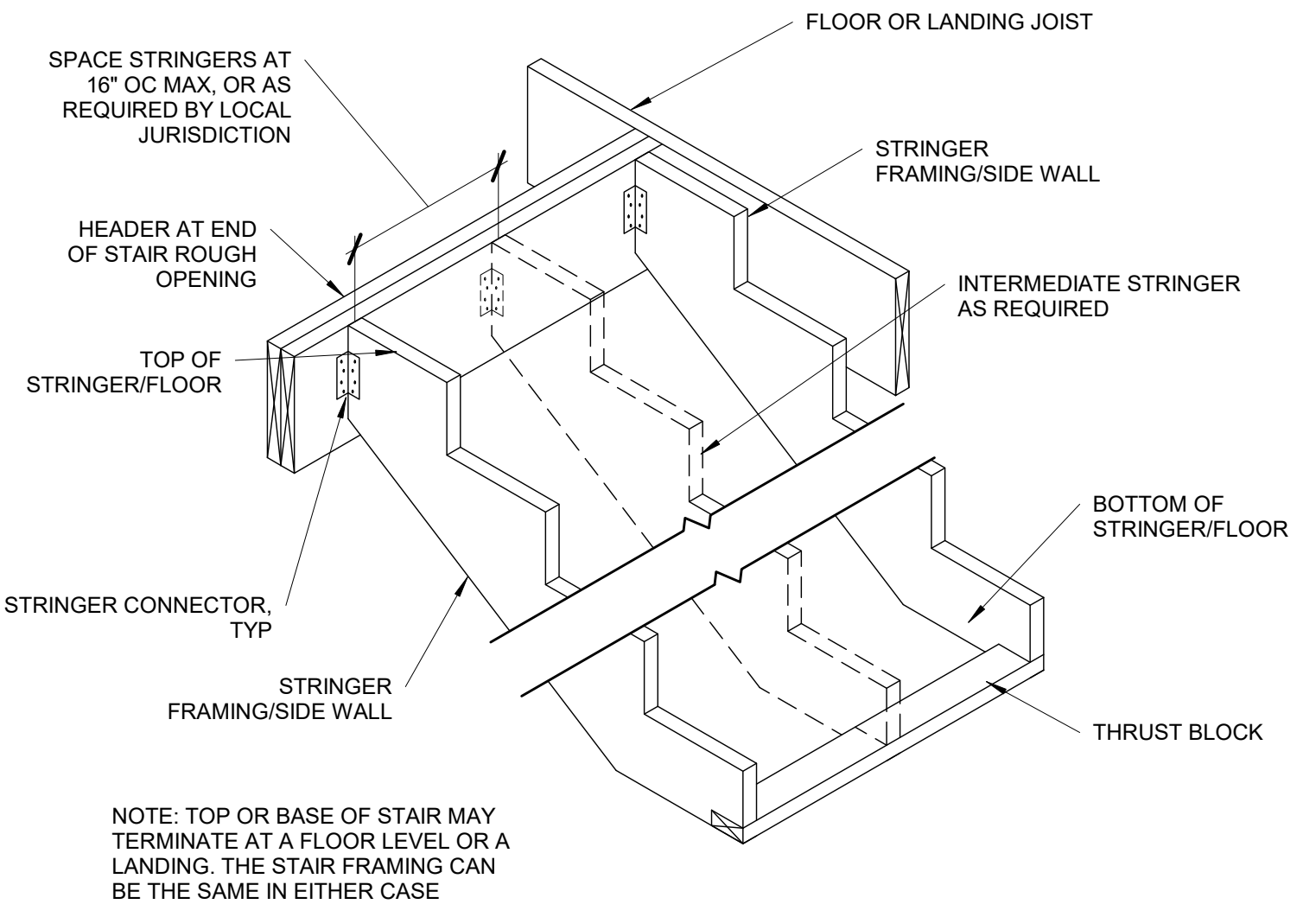

DECK LEDGER ATTACHMENT CHART

DECK JOIST SPAN	1/2" DIA LAG SPACING	EQUIVALENT SPACING FOR 16" OC JOIST BAYS
UP TO 10'-0"	16" OC	N/A
10'-1" TO 12'-0"	15" OC	16" OC DBL EVERY OTHER
12'-1" TO 14'-0"	13" OC	16" OC DBL EVERY OTHER
14'-1" TO 16'-0"	11" OC	16" OC DBL EVERY JOIST BAY
16'-1" TO 18'-0"	10" OC	16" OC DBL EVERY JOIST BAY

NOTE: CHART IS APPLICABLE ONLY WHEN DECK IS SHOWN ON APPROVED PLAN.

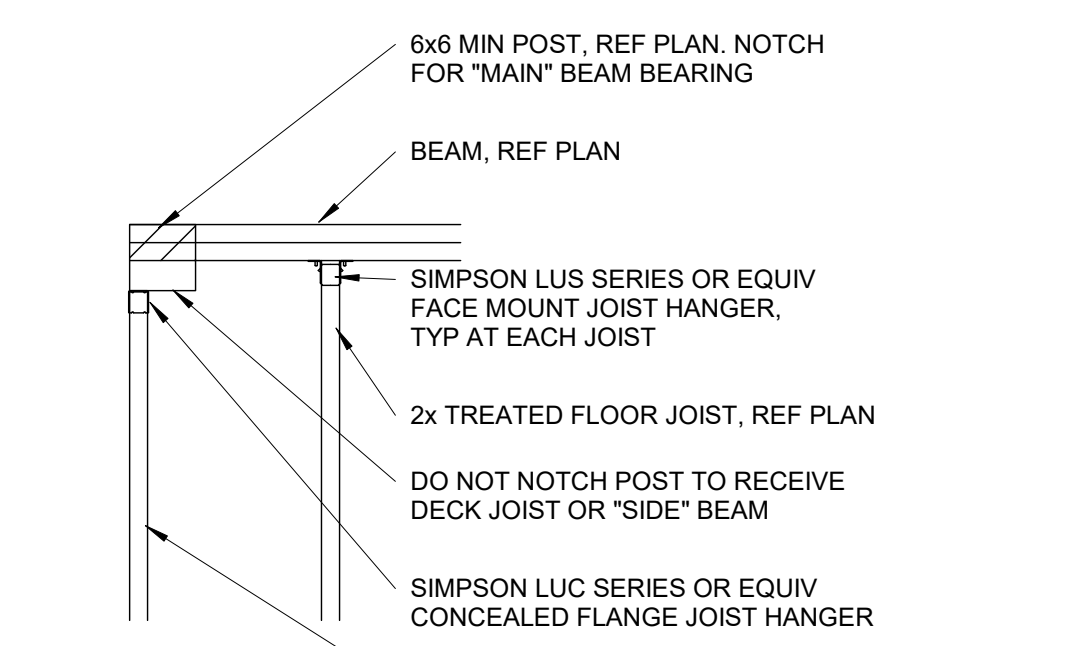
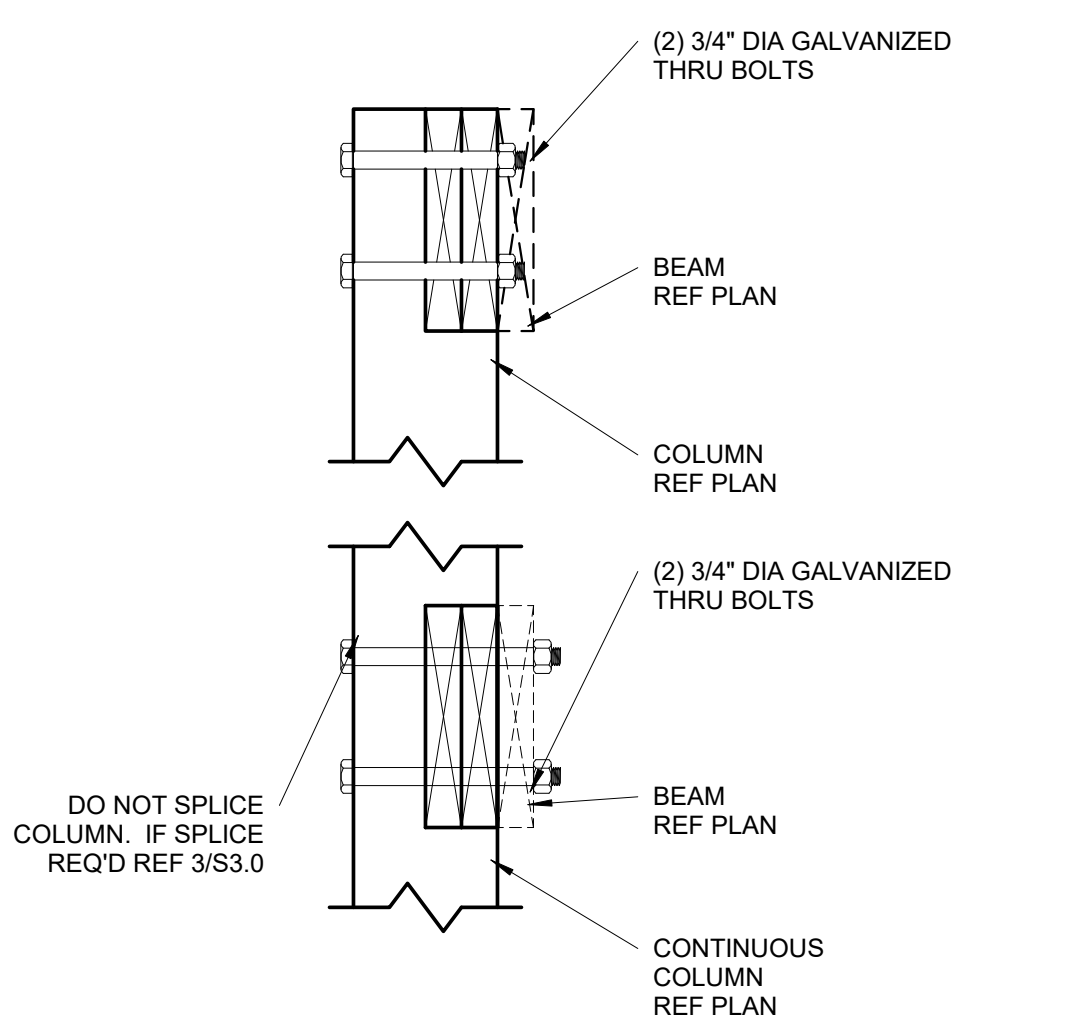
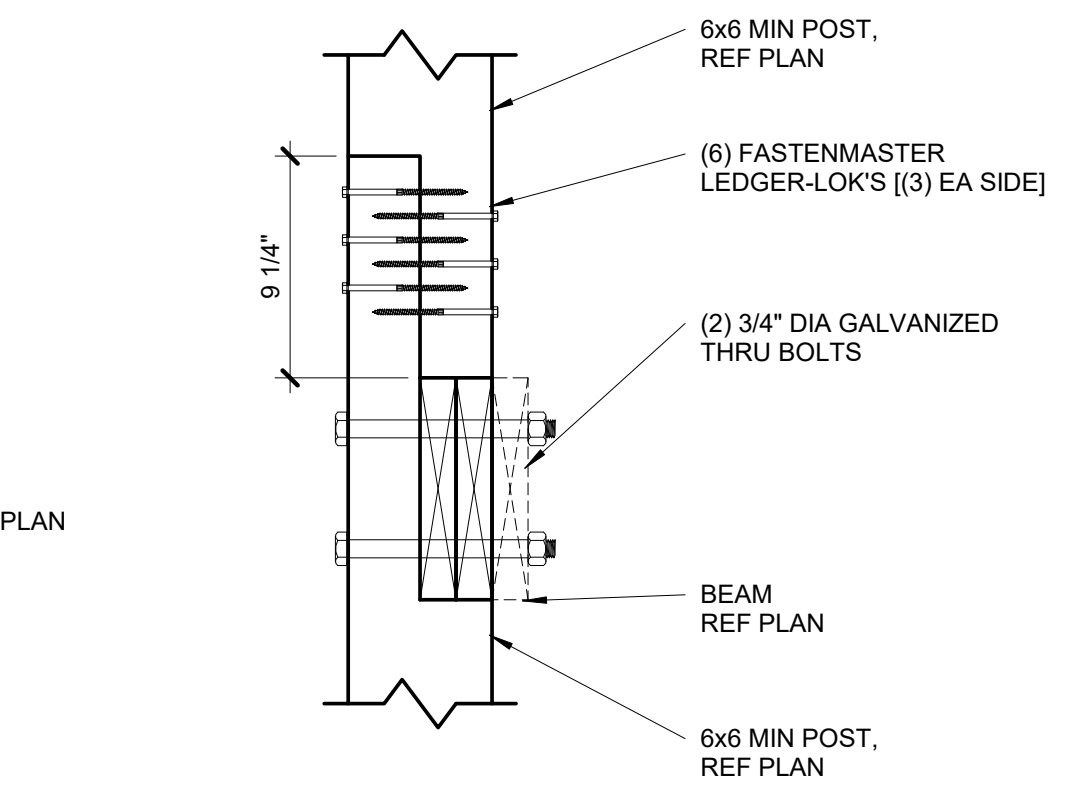
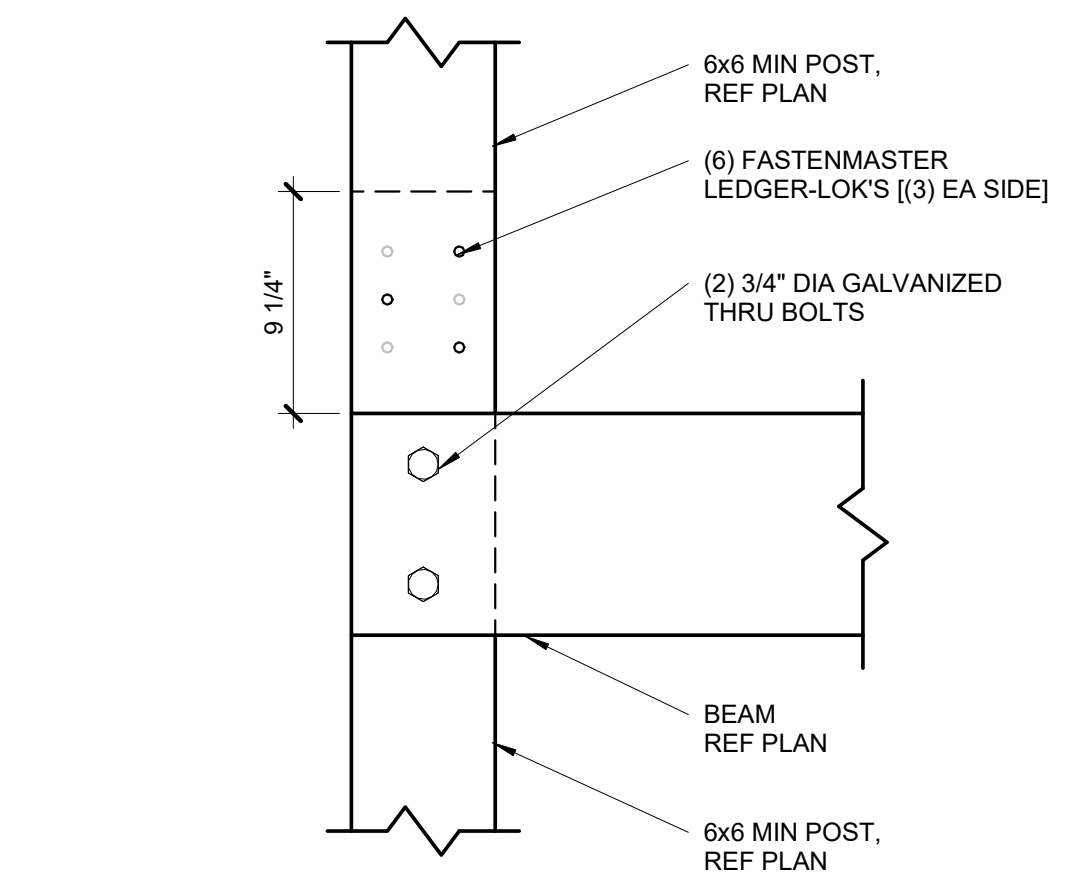
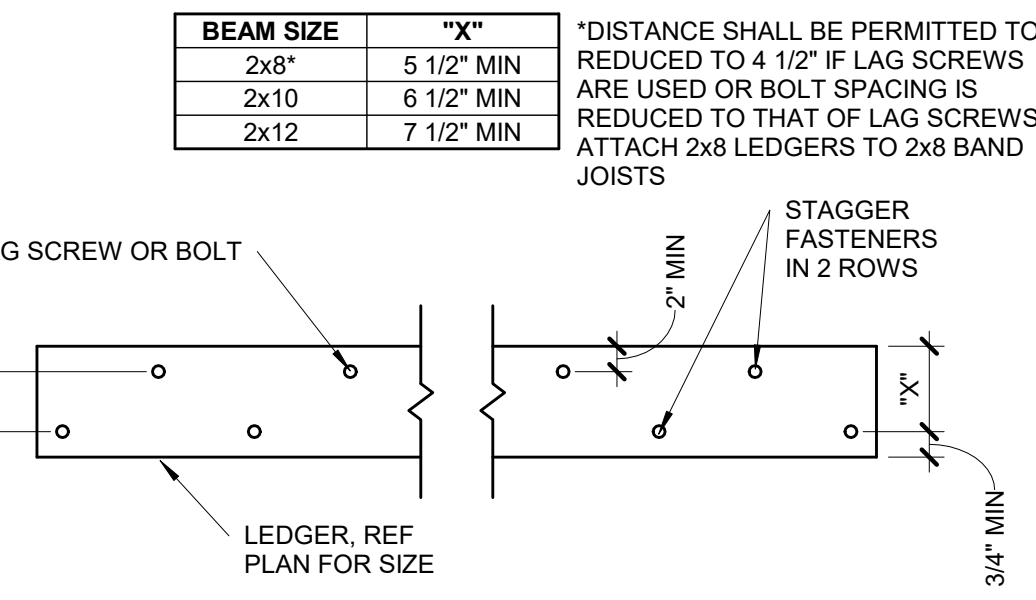

12 TYPICAL WALL CROSS-SECTION S3.0 3/4" = 1'-0"

9 UPSET STEEL BEAM/JOIST CONNECTION S3.0 1 1/2" = 1'-0"

8 LEDGER FASTENER PLACEMENT S3.0 1 1/2" = 1'-0"

4 SPLICED DECK COLUMN CONNECTION S3.0 1 1/2" = 1'-0"

7 TYPICAL CANTILEVER FRAMING WITH DECK ATTACHMENT S3.0 3/4" = 1'-0"

3 SPLICED DECK COLUMN CONNECTION S3.0 1 1/2" = 1'-0"

11 TYPICAL STRINGER DETAIL S3.0 3/4" = 1'-0"

6 TYPICAL LEDGER ATTACHMENT S3.0 3/4" = 1'-0"

2 DECK BEAM/COLUMN CONNECTION S3.0 1 1/2" = 1'-0"

5 TYPICAL LEDGER BOLT SPACING S3.0 3/4" = 1'-0"

DECK BEAM/COLUMN CORNER CONDITION S3.0 3/4" = 1'-0"

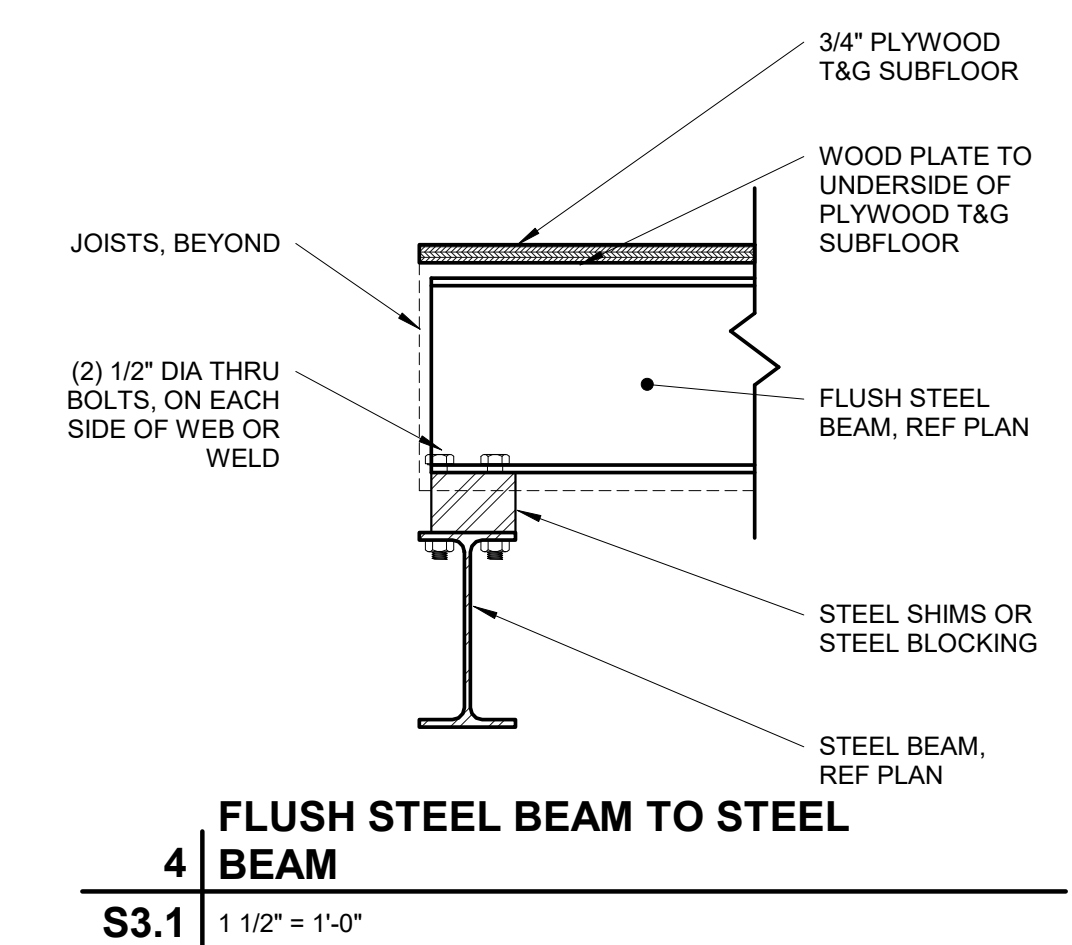

4 FLUSH STEEL BEAM TO STEEL BEAM
S3.1 1 1/2" = 1'-0"

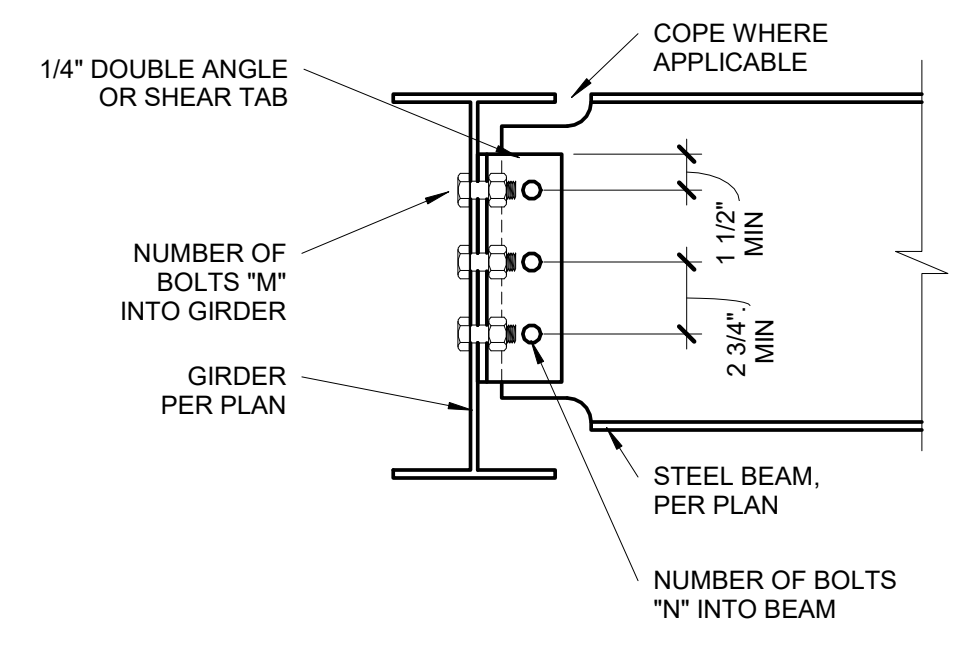

3 BEAM TO GIRDER CONNECTION
S3.1 1 1/2" = 1'-0"

BEAM SIZE	# OF BOLTS "N"	# OF BOLTS "M"
W8, W10	2	4
W12, W14	3	6
W16, W18	4	8

NOTES:
1. THESE CONNECTIONS ARE TYPICAL, UNO.
2. NUMBER OF BOLTS IN UPSET BEAM CONNECTIONS DETERMINED BY SMALLER OF TWO BEAMS AT CONNECTION.
3. ALL AROUND 1/4" FILLET WELD MAY BE SUBSTITUTED FOR EITHER BOLTED CONNECTION.
4. ALL BOLTS 3/4" DIAMETER, A325-N, UNO.

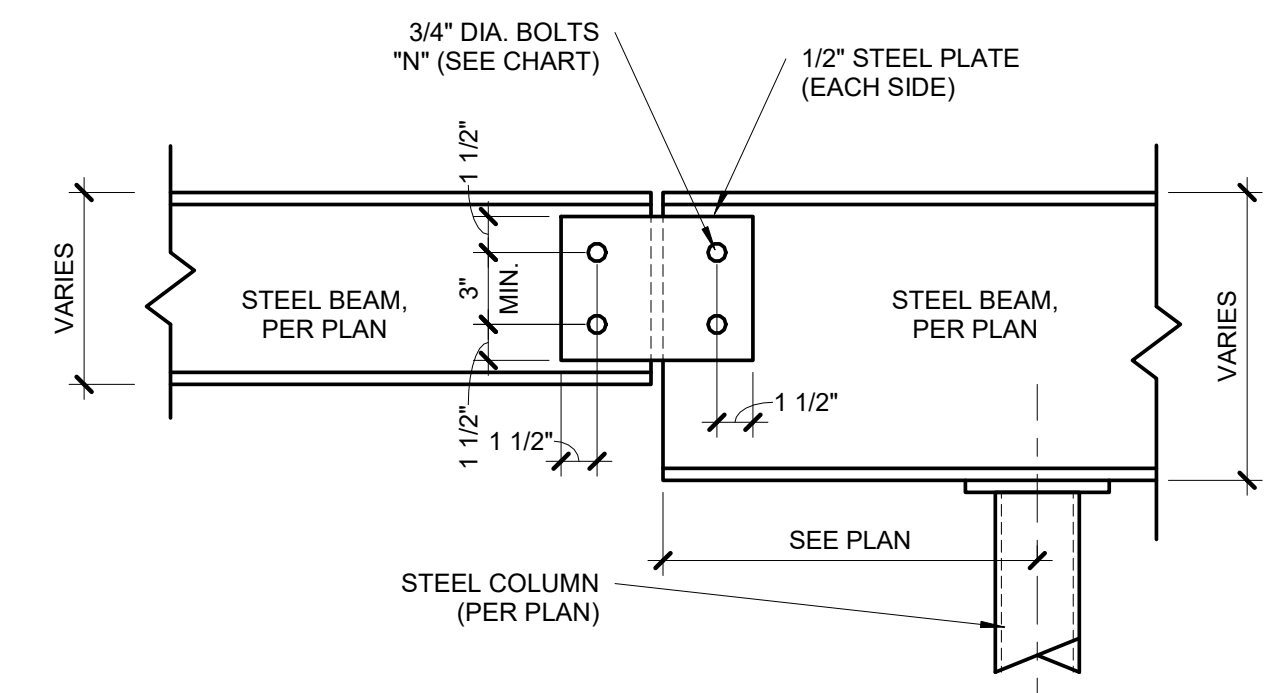

2 BEAM SPLICE DETAIL
S3.1 1 1/2" = 1'-0"

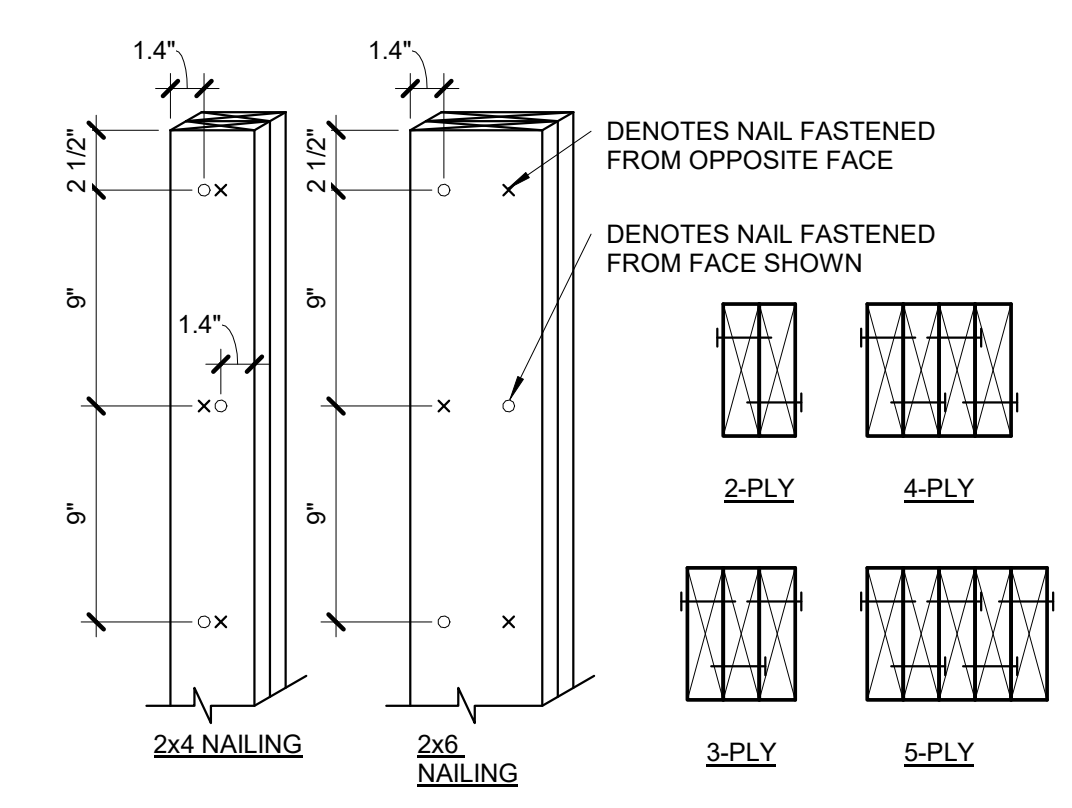

1 BUILT-UP STUD COLUMN
S3.1 1 1/2" = 1'-0"

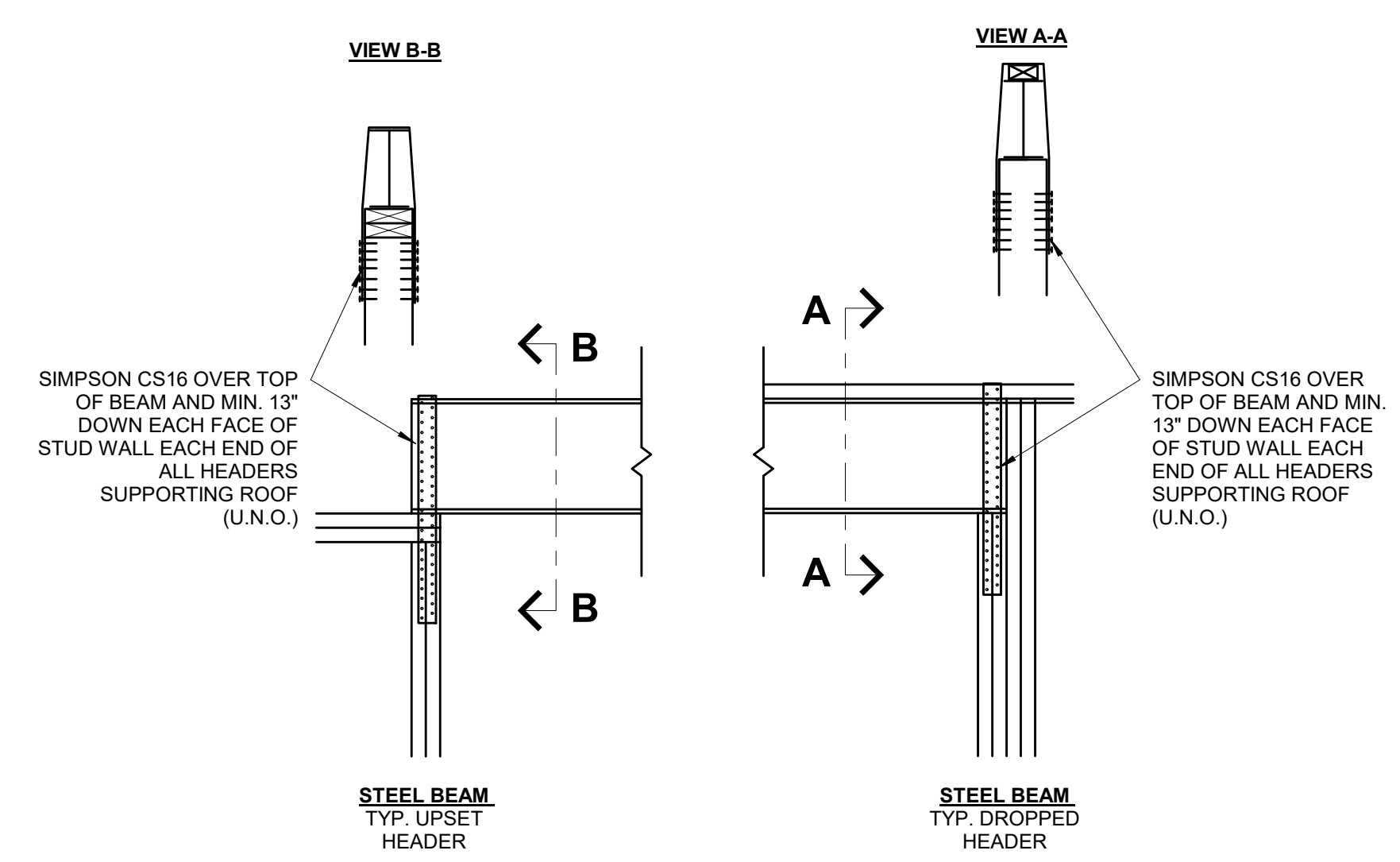

6 ROOF SUPPORTING BEAM HOLD DOWN
S3.1 3/4" = 1'-0" (COMPLIANCE WITH IRC R602.11)

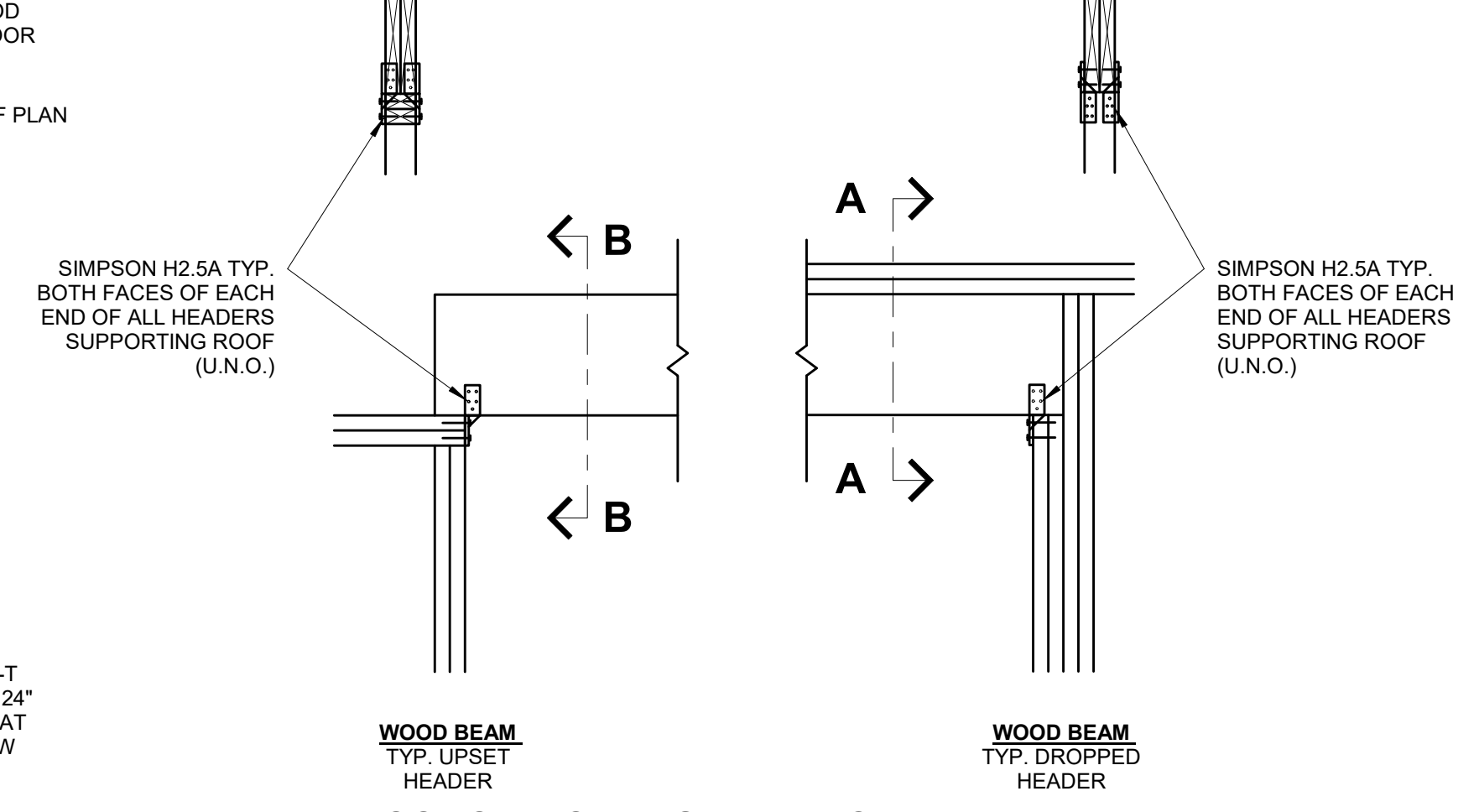

9 WOOD PLATE TO STEEL BEAM CONNECTION
S3.1 1 1/2" = 1'-0"

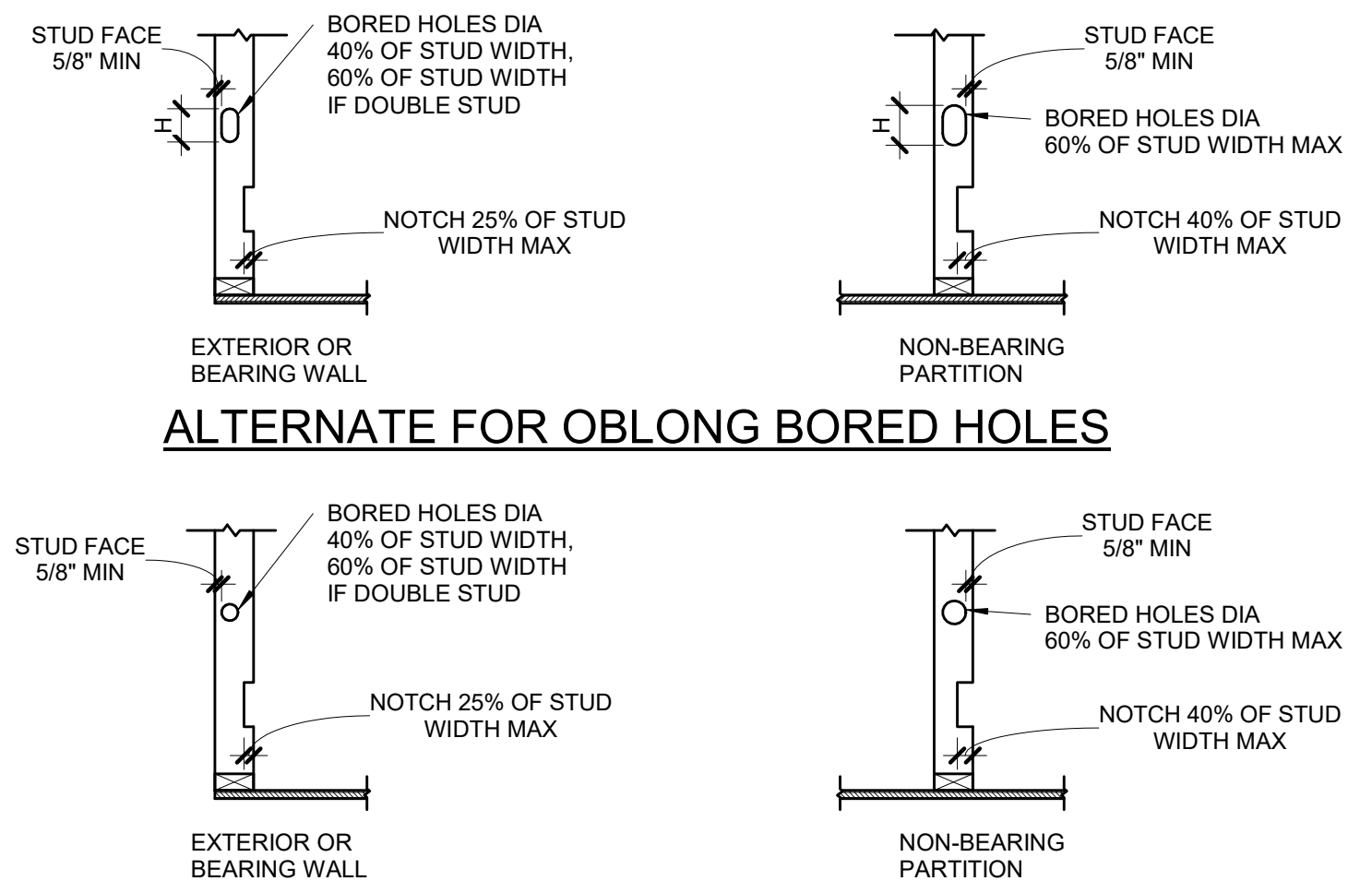

WALL SIZE	BORED HOLE SIZE		WALL NOTCH	
	STUDS LOAD BEARING OR EXTERIOR WALL	NON LOAD BEARING WALL	LOAD BEARING WALL	NON LOAD BEARING WALL
2x4	1 3/8"	2 1/8"	7/8"	1 3/8"
(2) 2x4	-	2 1/8"	7/8"	1 3/8"
2x6	2 1/4"	-	3 15/16"	2 1/4"
(2) 2x6	-	3 5/16"	3 1/8"	2 1/4"
2x8	2 7/8"	-	4 3/8"	2 7/8"
(2) 2x8	-	4 3/8"	4 3/8"	2 7/8"

PLATES:
TOP AND BOTTOM PLATE HOLE, CUT OR NOTCH THAT IS 50% MORE OF WIDTH MUST BE REPAIRED USING 16 GA (MIN) METAL TIE THAT IS AT LEAST 1-1/2" WIDE IF WALL IS A SHEAR WALL IT MUST BE REPAIRED USING HARDY FRAME SADDLE (HFS).

WALL SIZE	HOLE SIZE	VERTICAL HOLE SIZE (H)
2x4	1 3/4"	D+1/2" AT LVLs 1&2
2x6	2 3/4"	D+1" AT LVL 3
2x8	3 5/8"	D+1 1/4" AT LVL 4
		D+1 1/2" AT LVL 5

NOTE:
SEE SECTION R602.6 AND FIGURES R602.6.1 AND R602.6.2

5 DRILLING & NOTCHING DETAIL
S3.1 3/4" = 1'-0"

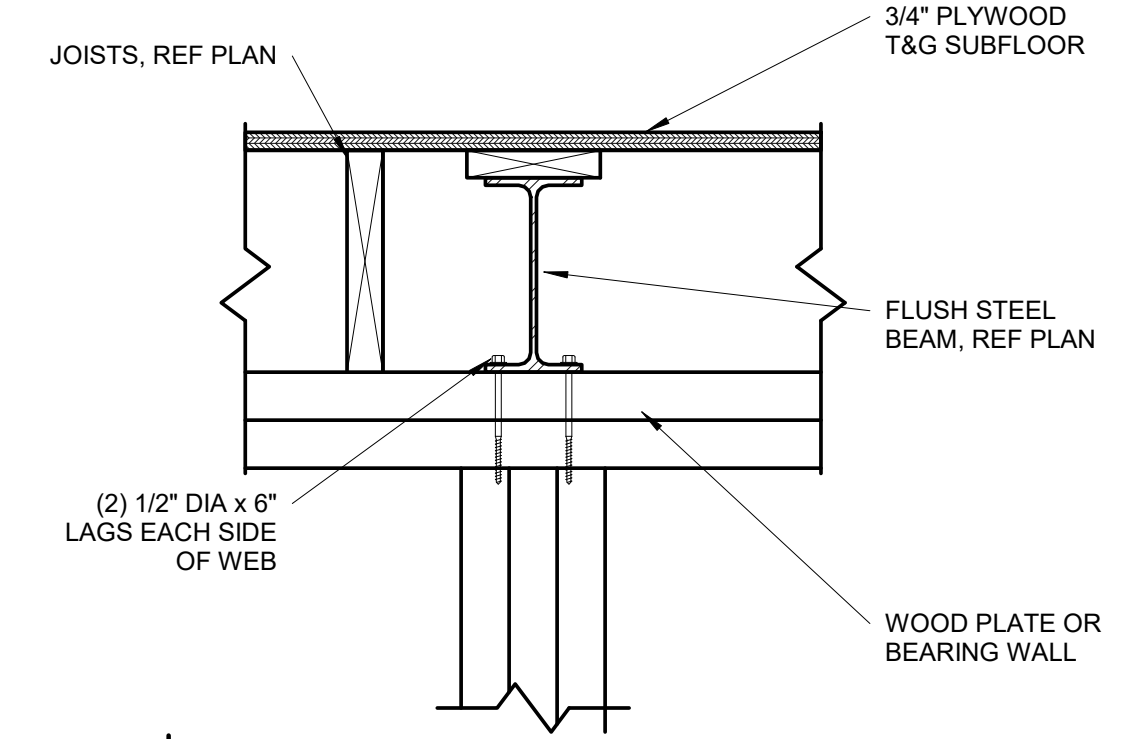

8 FLUSH STEEL BEAM CONNECTION
S3.1 1 1/2" = 1'-0"

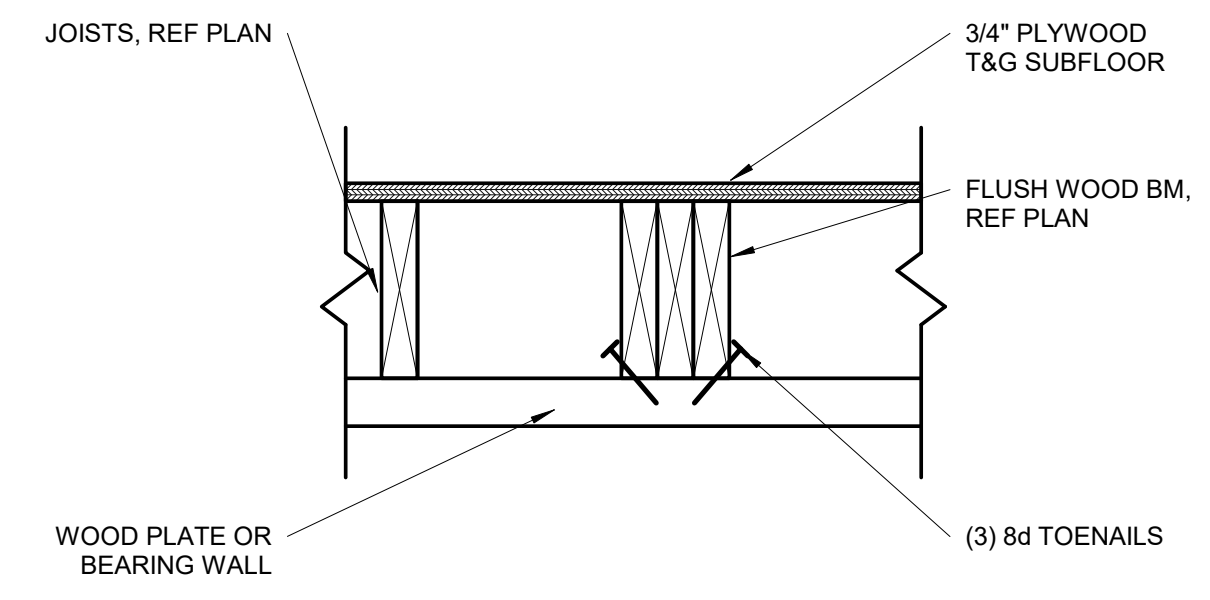

7 FLUSH WOOD BEAM CONNECTION
S3.1 1 1/2" = 1'-0"

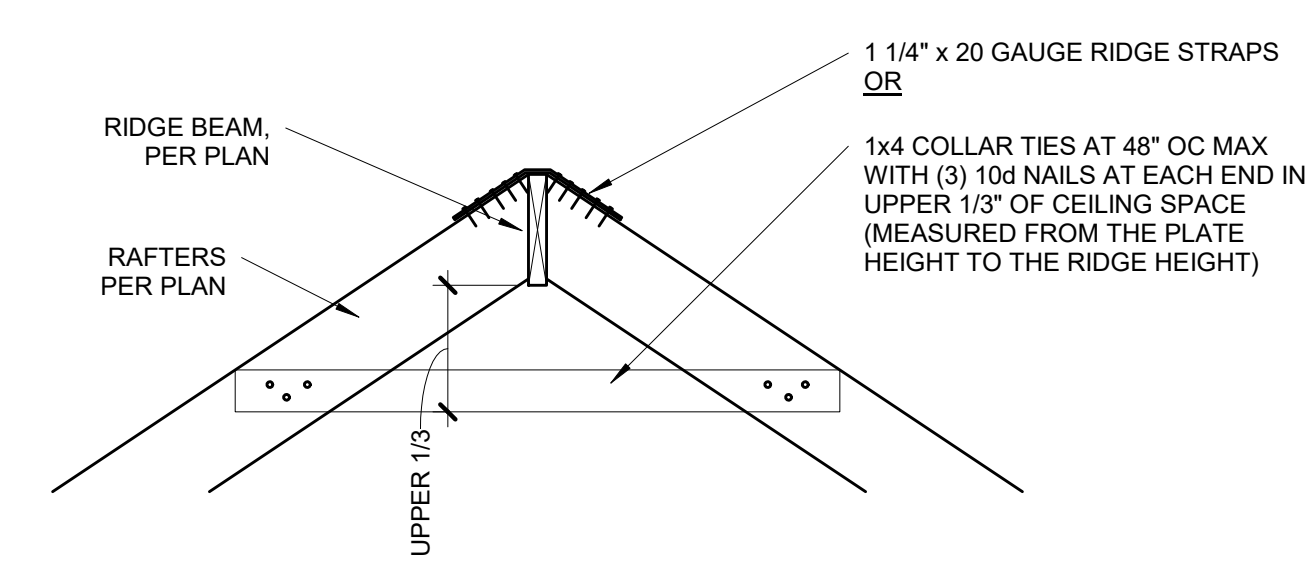

12 RIDGE BEAM DETAIL
S3.1 3/4" = 1'-0"

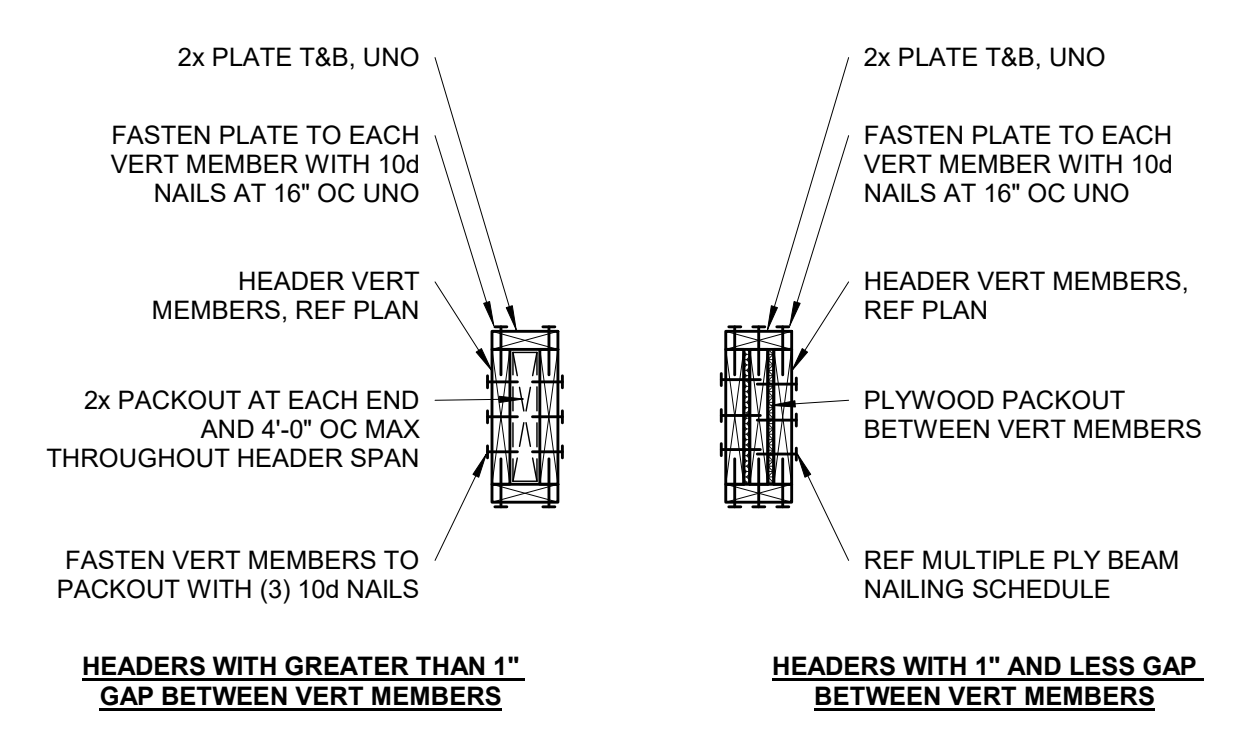

11 TYPICAL WOOD HEADER DETAIL
S3.1 NOT TO SCALE

2 - PLY	3 - PLY	4 - PLY
(3) ROWS OF 16d x 3-1/2" NAILS AT 6" OC	(3) ROWS OF 16d x 3-1/2" NAILS AT 4" OC	(2) ROWS OF 1/2" DIA. A307 THRU-BOLTS AT 12" OC STAGGERED

NOTES:
1. NAILING SHOWN APPLIES UNLESS SPECIFICALLY NOTED IN DETAILS.
2. SPACE NAILS EVENLY THROUGHOUT DEPTH OF BEAM.

10 MULTIPLE PLY BEAM NAILING SCHEDULE
S3.1 NOT TO SCALE

1 BUILT-UP STUD COLUMN
S3.1 1 1/2" = 1'-0"

DATE	COMMENTS

UPLIFT CONNECTION SCHEDULE

OVERHANG SPAN: 1'-11" TO 1'-9"			
RAFTER SPACING	UPLIFT CONNECTOR	EXPOSURE B	EXPOSURE C
12" OC	SIMPSON H2.5A	(1) AT 24" OC	(1) AT 24" OC
16" OC	SIMPSON H2.5A	(1) AT 32" OC	(1) AT 16" OC
24" OC	SIMPSON H2.5A	(1) AT 24" OC	(1) AT 24" OC
OVERHANG SPAN: 1'-10" TO 2'-6"			
RAFTER SPACING	UPLIFT CONNECTOR	EXPOSURE B	EXPOSURE C
12" OC	SIMPSON H2.5A	(1) AT 12" OC	(1) AT 12" OC
16" OC	SIMPSON H2.5A	(1) AT 16" OC	(2) AT 16" OC
24" OC	SIMPSON H2.5A	(2) AT 24" OC	(2) AT 24" OC
OVERHANG SPAN: 2'-7" TO 3'-9"			
RAFTER SPACING	UPLIFT CONNECTOR	EXPOSURE B	EXPOSURE C
12" OC	SIMPSON H2.5A	(2) AT 12" OC	(2) AT 12" OC
16" OC	SIMPSON H2.5A	(2) AT 16" OC	(2) AT 16" OC
24" OC	SIMPSON H2.5A	(2) AT 24" OC	N/A

OVERHANG SPAN	MIN BACKSPAN LENGTH
≤ 1'-0"	1'-0"
1'-1" to 2'-0"	EQUALS OVERHANG SPAN
≥ 2'-1"	OVERHANG SPAN x 2

NOTES:
-CHART IS ONLY APPLICABLE IF NO RAFTER BEAM SHOWN ON PLAN.
-CONTACT EOR IF OVERHANG LENGTH EXCEEDS CHART OPTIONS.
-ALTERNATE, REF BARGE RAFTER DETAIL FOR OVERHANGS 1'-0" OR LESS.

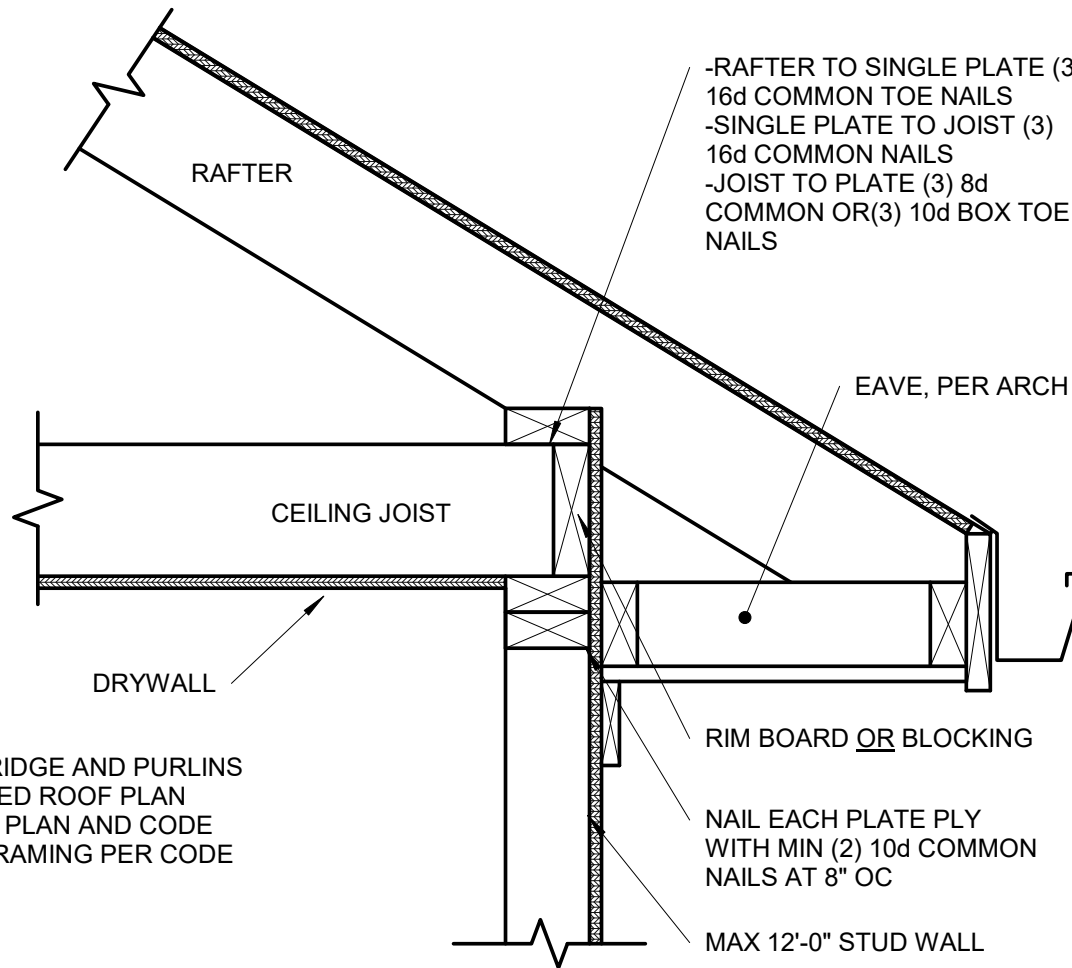

NOTES:
-SUPPORT ROOF RIDGE AND PURLINS PER APEX DESIGNED ROOF PLAN
-RAFTER TIES PER PLAN AND CODE
-REMAINDER OF FRAMING PER CODE

9 OPTIONAL RAFTER BEARING

S3.2 1 1/2" = 1'-0"

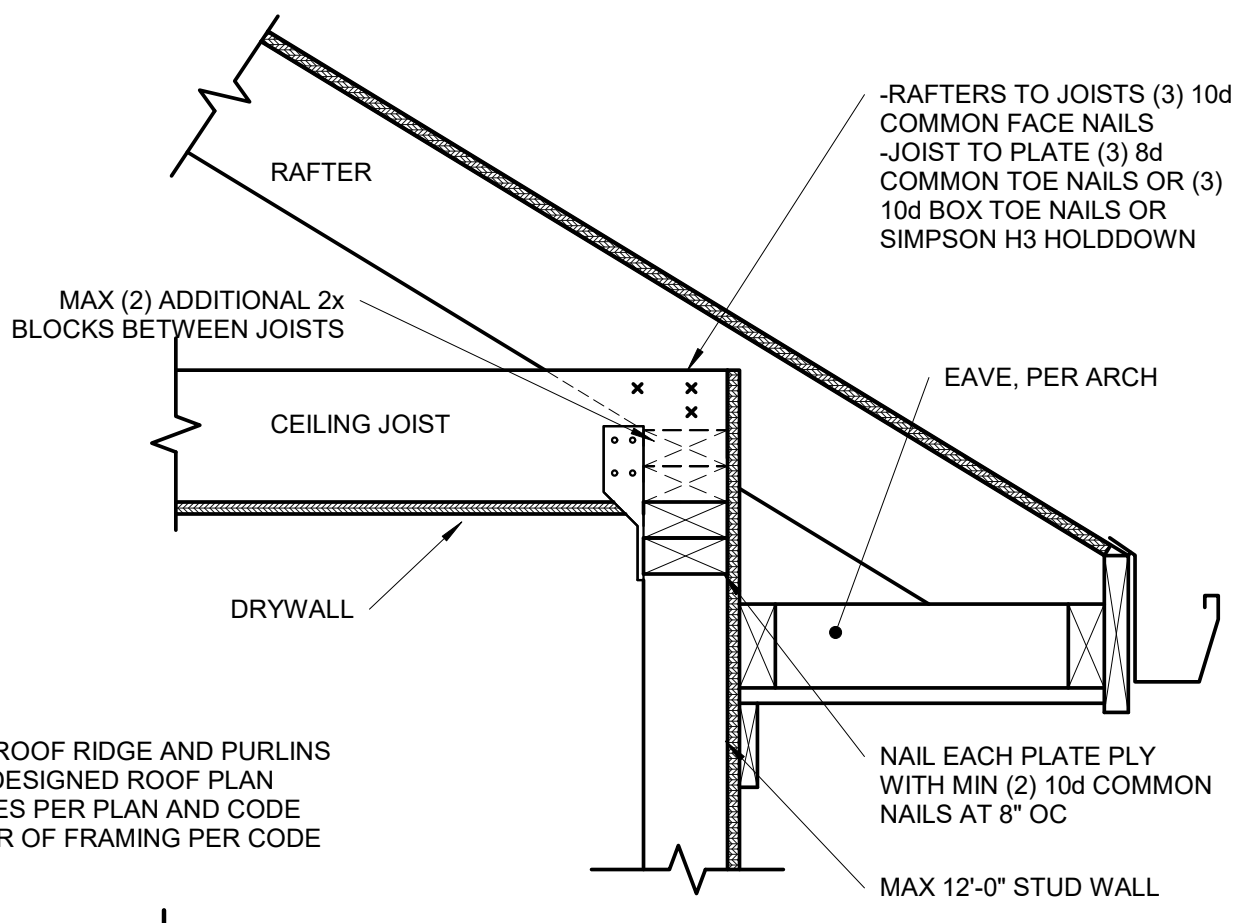

NOTES:
-SUPPORT ROOF RIDGE AND PURLINS PER APEX DESIGNED ROOF PLAN
-RAFTER TIES PER PLAN AND CODE
-REMAINDER OF FRAMING PER CODE

8 OPTIONAL RAFTER BEARING

S3.2 1 1/2" = 1'-0"

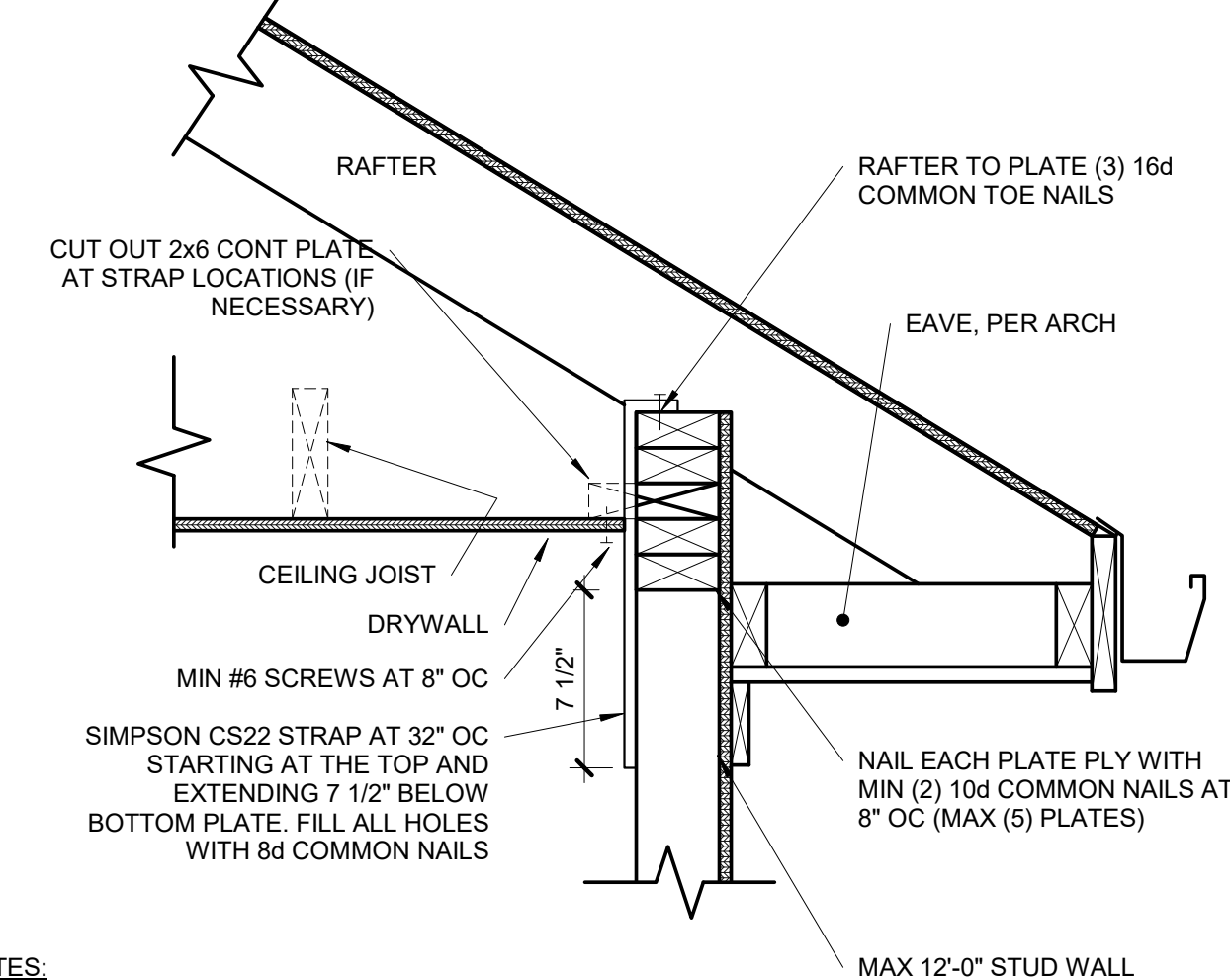

NOTES:
-SUPPORT ROOF RIDGE AND PURLINS PER APEX DESIGNED ROOF PLAN
-RAFTER TIES PER PLAN AND CODE
-REMAINDER OF FRAMING PER CODE

7 OPTIONAL RAFTER BEARING

S3.2 1 1/2" = 1'-0"

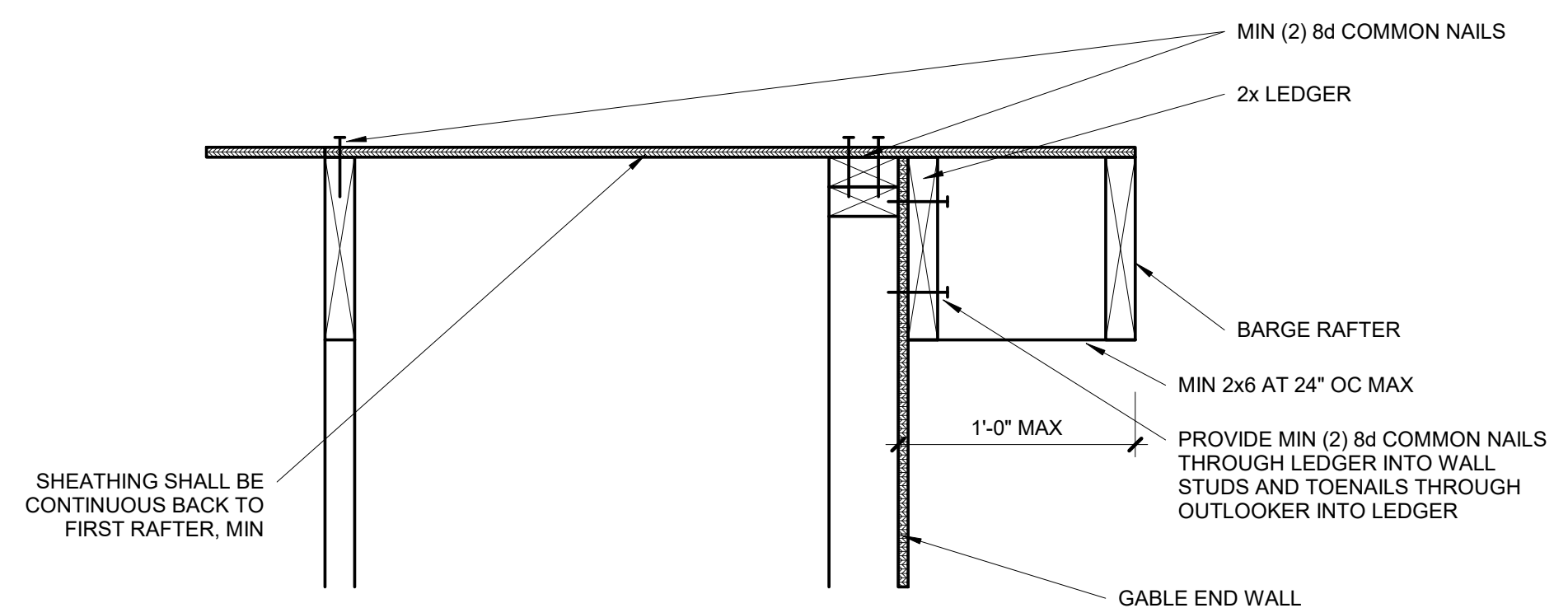

6 OPTIONAL OVERHANG 1'-0" OR LESS

S3.2 1 1/2" = 1'-0"

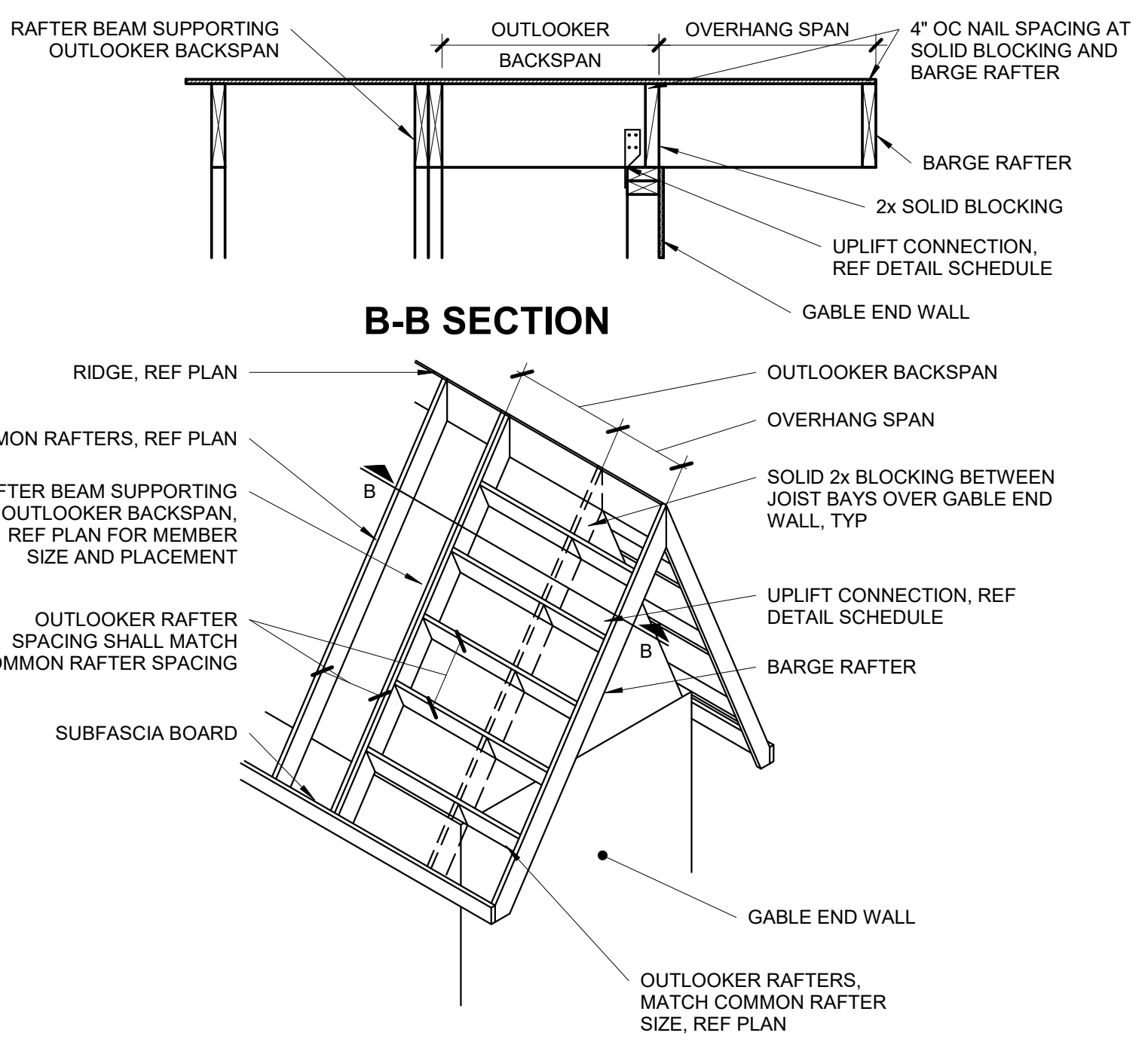

5 OUTLOOKER RAFTERS ROOF FRAMING

S3.2 NOT TO SCALE

REQUIRED NUMBER OF SISTER PLIES

LIGHT ROOF						
# OF SISTER PLIES	2x VALLEY			LVL VALLEY		
	2x6	2x8	2x10	2x6	2x8	2x10
0	4'-8"	6'-2"	7'-11"	8'-8"	11'-5"	14'-7"
1	9'-5"	-	-	1	-	-
2	-	N/A	N/A	2	N/A	N/A

HEAVY ROOF						
# OF SISTER PLIES	2x VALLEY			LVL VALLEY		
	2x6	2x8	2x10	2x6	2x8	2x10
0	3'-6"	4'-7"	5'-11"	6'-6"	8'-7"	10'-11"
1	7'-1"	9'-3"	-	1	13'-1"	-
2	-	-	N/A	2	-	N/A

*VALLEYS OF A LENGTH GREATER THAN THAT FOUND IN THE CELL ABOVE ARE CONTROLLED BY BENDING. APPLY THE NUMBER OF SISTER PLIES CORRESPONDING TO THIS ROW.
1. THIS TABLE IS INTENDED TO BE USED IN CONJUNCTION WITH THE STAMPED, ENGINEERED PLANS AS THEY ARE DRAWN BY APEX. BRACING LOCATIONS SHALL DETERMINE HORIZONTAL UNSUPPORTED SPAN FROM VALLEY BEARING AND BE USED TO DETERMINE THE NUMBER OF SISTERS REQUIRED. BRACING LOCATIONS ARE NOT TO BE INFERRED USING THIS TABLE.
2. TABLE VALUES ARE BASED ON A DEPTH OF MEMBER REMAINING, d, EQUAL TO THE DEPTH OF THE RAFTERS. IF d IS OBSERVED TO BE LESS THAN THE DEPTH OF THE RAFTER, THE VALLEY WILL NEED TO BE EITHER REPLACED OR ANALYZED BY APEX.
3. TABLE VALUES ARE VALID FOR TAPERED CUTS ONLY. REF DETAIL 4/S3.2.
4. IF MULTI-PLY VALLEY IS SPECIFIED ON PLAN TREAT EACH ADDITIONAL PLY AS A SISTER PLY WHEN LOOKING UP MAX SPAN.
5. MAX 14'-0" HORIZONTAL RAFTER SPAN IN BOTH DIRECTIONS FROM VALLEY.
6. ALL HIPS ARE DESIGNED TO BE CONTROLLED BY BENDING. SHEAR AT BEARING WITH MIN 5 1/2" DEPTH DOES NOT CONTROL DESIGN.

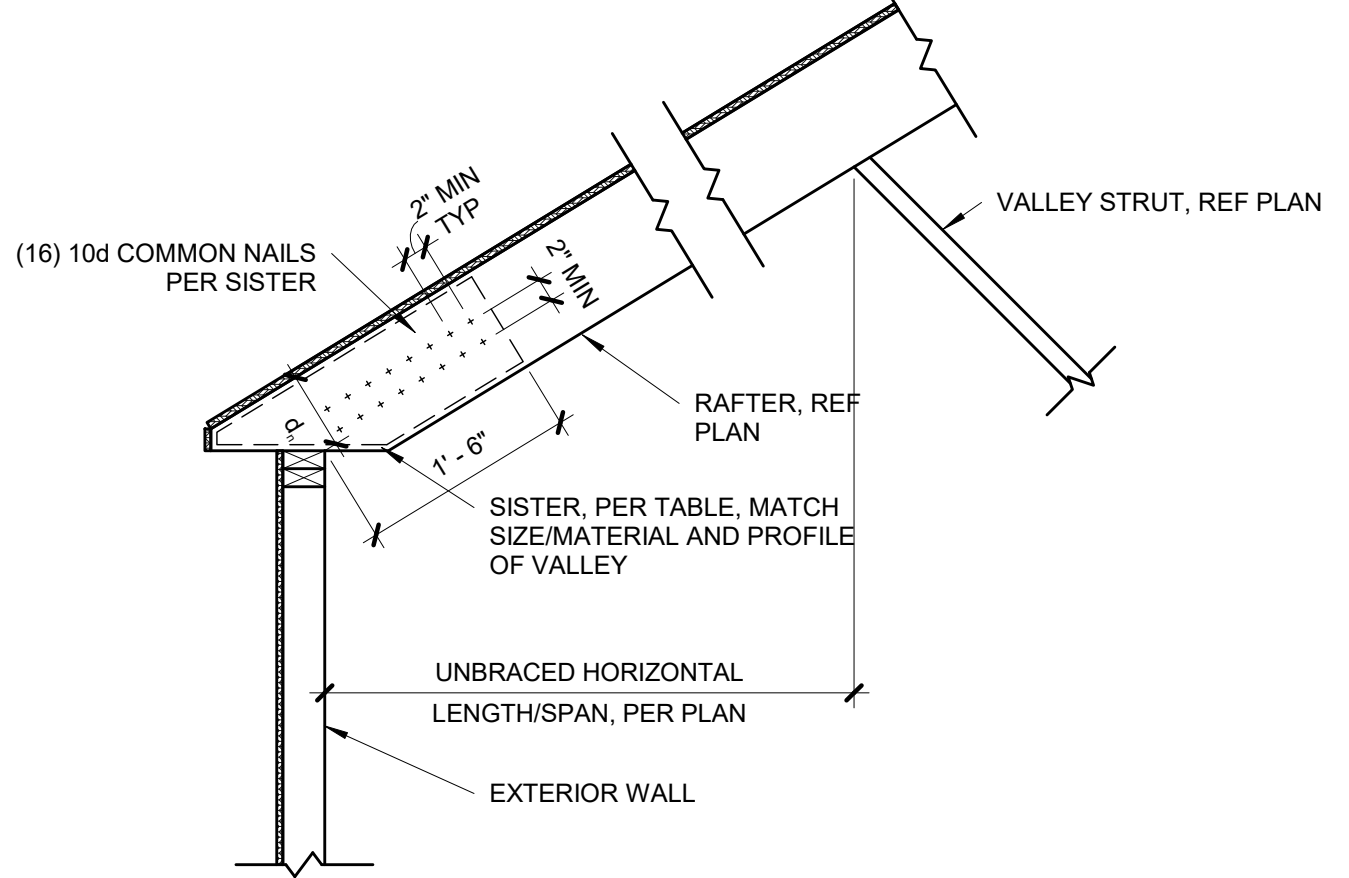

4 TAPERED VALLEY

S3.2 3/4" = 1'-0"

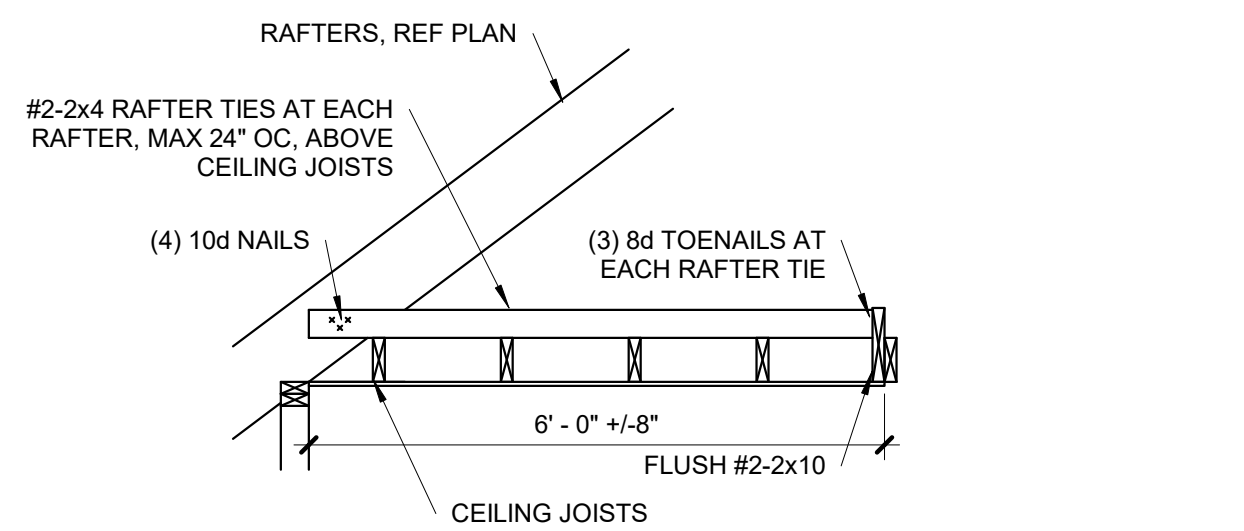

A-A SECTION

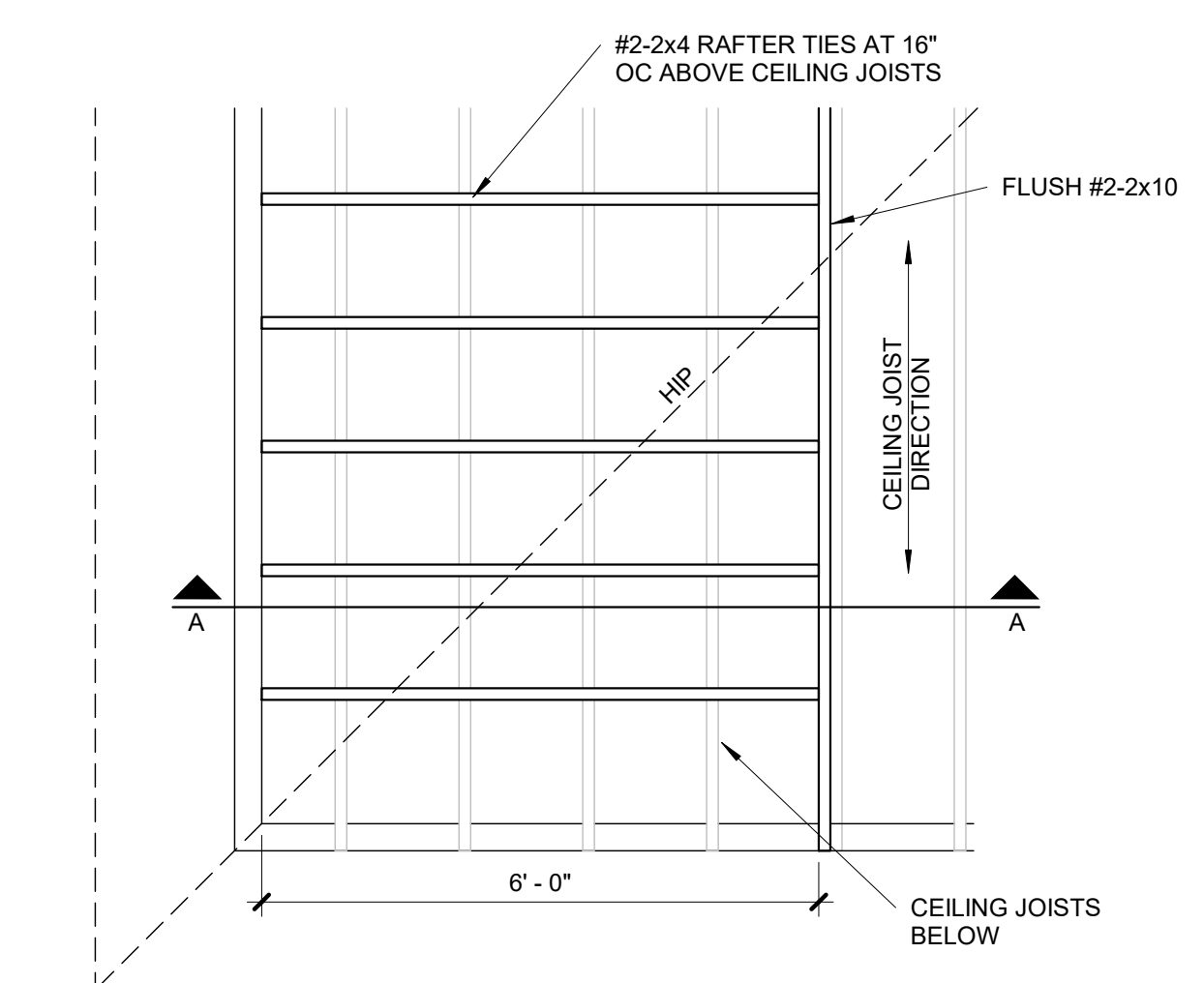

3 ROOF WITH PERP CEILING JOISTS

S3.2 1/2" = 1'-0"

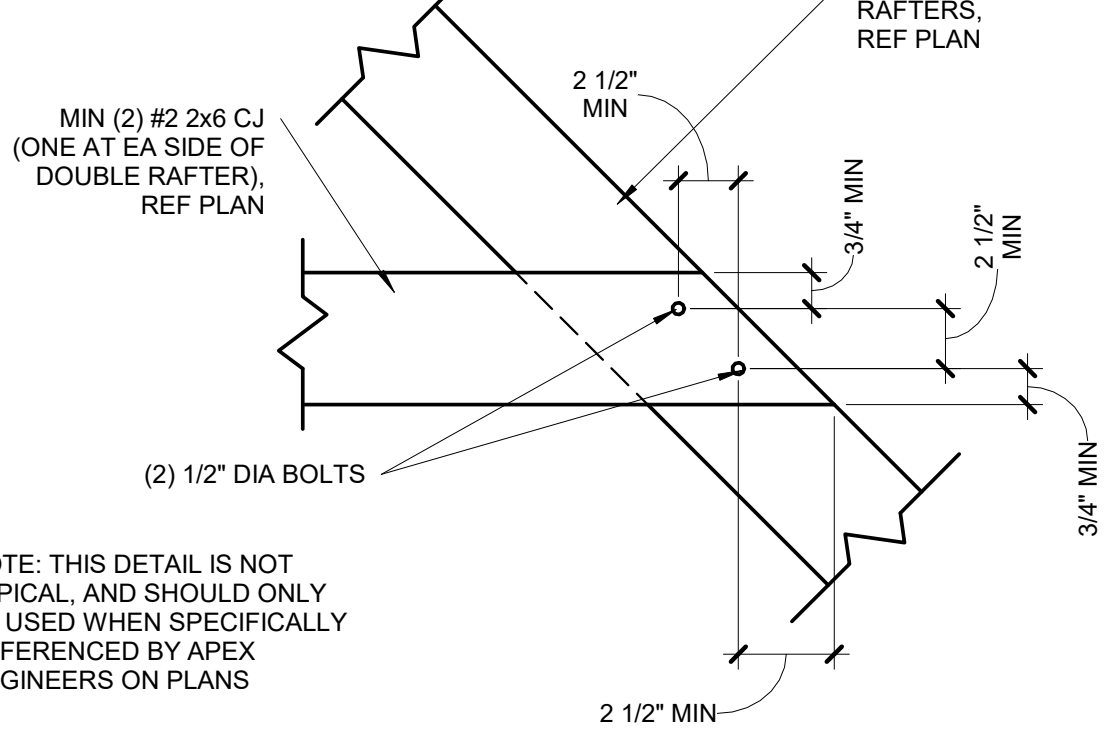

NOTE: THIS DETAIL IS NOT TYPICAL, AND SHOULD ONLY BE USED WHEN SPECIFICALLY REFERENCED BY APEX ENGINEERS ON PLANS

2 BOLTED RAFTER HIP CONNECTION

S3.2 1 1/2" = 1'-0"

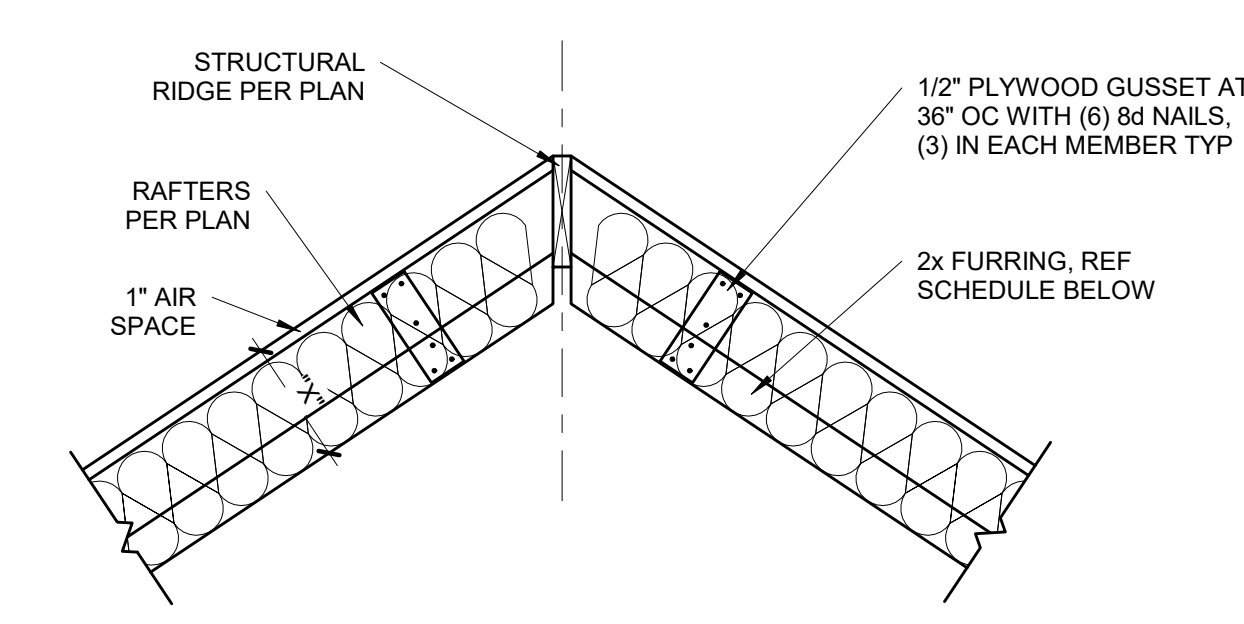

FURR OUT SCHEDULE

RAFTER SIZE	R-30C INSULATION (X=9 1/4")	R-38C INSULATION (X=11 1/4")
2x6	2x6	2x8
2x8	2x4	2x6
2x10	NOT REQUIRED	2x4
2x12	NOT REQUIRED	REQUIRED

NOTES:
1. ALL VAULTED RAFTERS SHALL BE #2-2x6 DF-L, MINIMUM, AT 16" OC, PER SPAN CHART, UNLESS NOTED OTHERWISE.
2. ALL VAULTS SHALL BE FURRED DOWN WITH 2x FRAMING TO THE REQUIRED DEPTH OF INSULATION, PLUS 1" AIR SPACE.
3. R-30C INSULATION = 8 1/4" THICK
4. R-38C INSULATION = 10 1/4" THICK
5. INSULATION REQUIREMENTS MAY BE REDUCED TO R30 IF ROOF/CEILING ASSEMBLY DOES NOT ALLOW SUFFICIENT SPACE BUT IS LIMITED TO VAULTED CEILING AREAS THAT ARE LESS THAN 500 SQUARE FEET OR 20 PERCENT OF THE TOTAL INSULATED CEILING AREA, WHICHEVER IS LESS. (PER N1102.2.2)

1 VAULTED RAFTER INSULATION FURR OUT

S3.2 3/4" = 1'-0"

DATE	COMMENTS

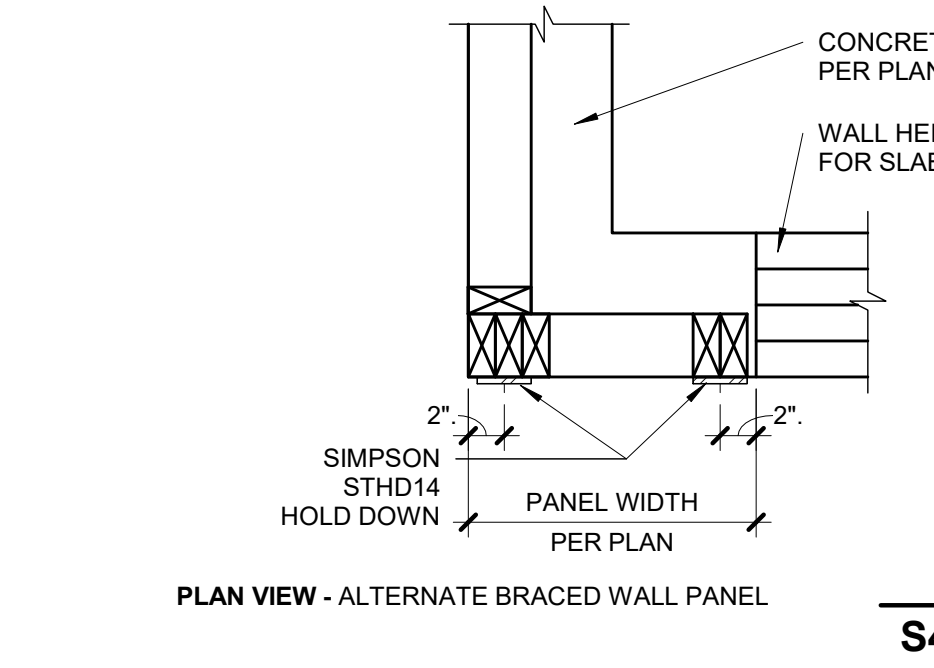
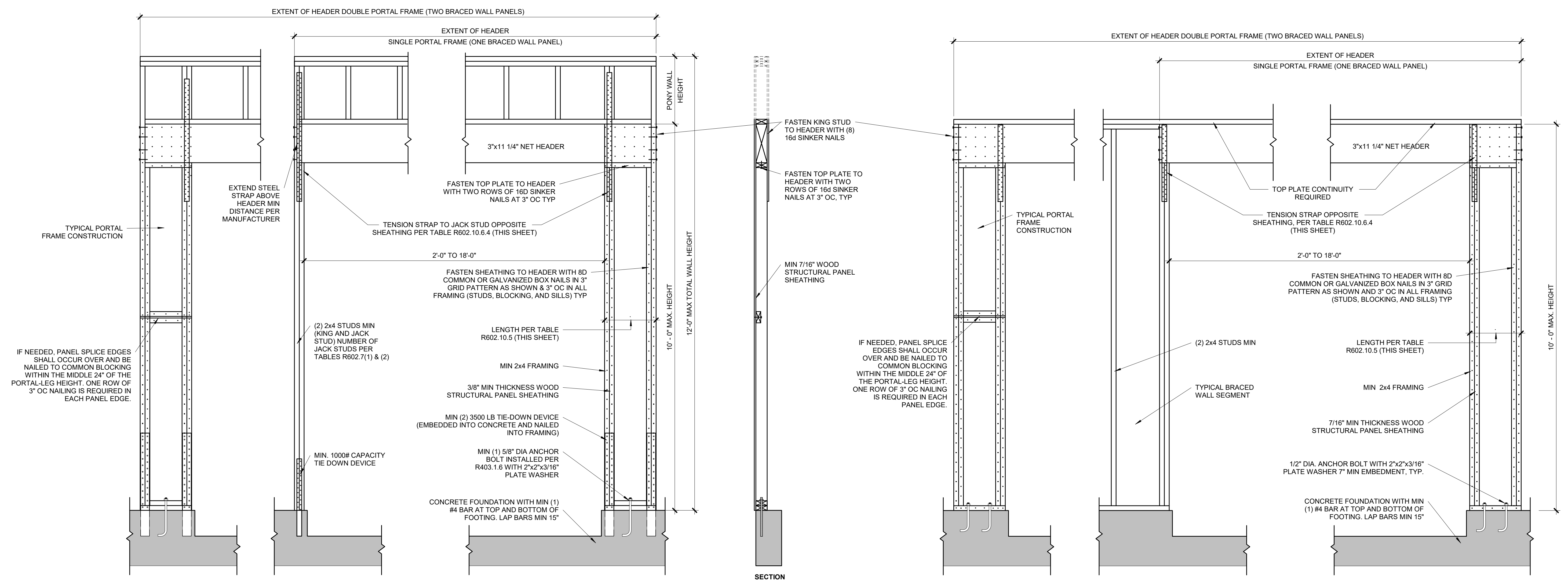

1 PORTAL FRAME WITH HOLD DOWNS (METHOD PFH)
S4.0 3/4" = 1'-0" (PER IRC R602.10.6.2)

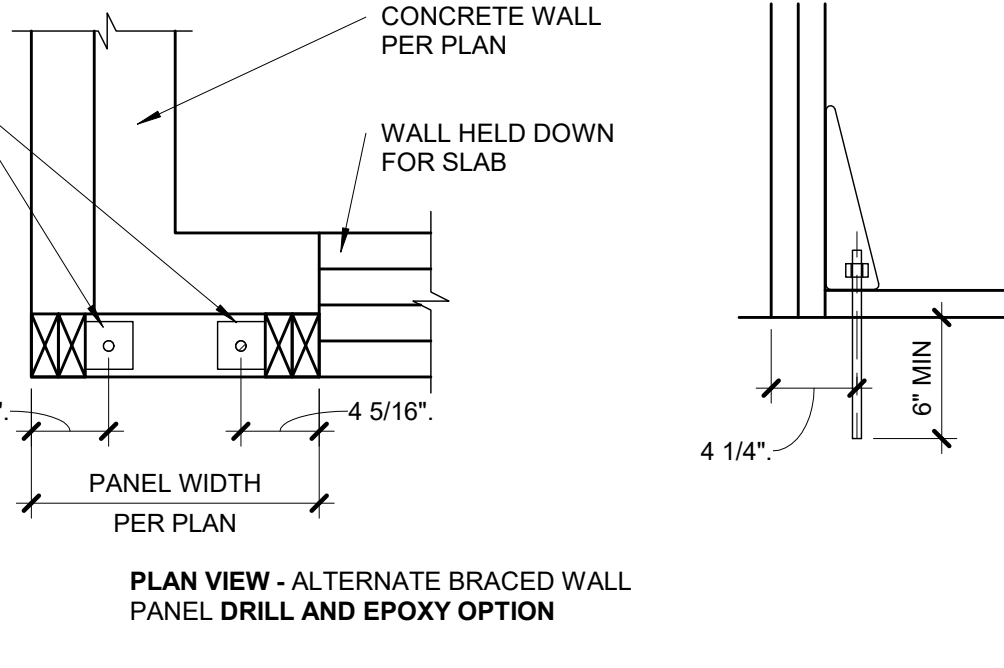

PLAN VIEW - ALTERNATE BRACED WALL PANEL DRILL AND EPOXY OPTION

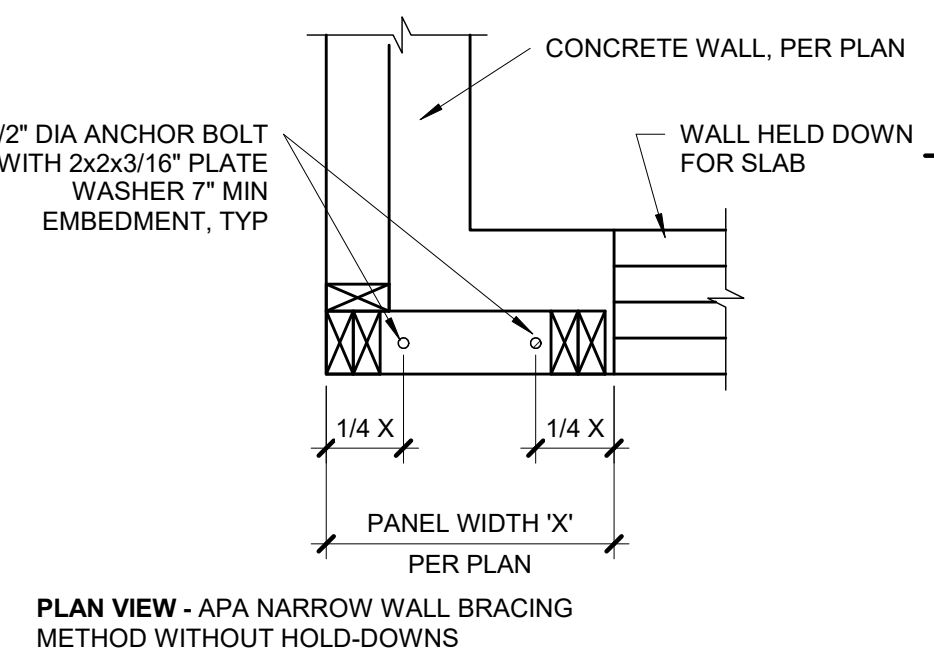

PLAN VIEW - APA NARROW WALL BRACING METHOD WITHOUT HOLD-DOWNS

PORTAL FRAME AT GARAGE DOOR WITHOUT HOLD DOWNS (METHOD PFG)
S4.0 ALT 3/4" = 1'-0" (ALT ALLOWED AT GARAGE DOOR ONLY) (PER IRC R602.10.6.3)

TABLE R602.10.5 (PARTIAL)

METHOD	MINIMUM LENGTH OF BRACED WALL PANELS			
	MIN LENGTH (INCHES)			
	8 FEET	9 FEET	10 FEET	11 FEET
SUPPORTING ROOF ONLY	16	16	16	16
ONE STORY AND ROOF	24	24	24	24
PFG	24	27	30	30

NOTE: MAX HEADER HEIGHT IS 10'-0", BUT WALL HEIGHT SHALL BE PERMITTED TO BE INCREASED TO 12'-0" WITH PONY WALL

TABLE R602.10.6.4

TENSION CAPACITY STRAP TABLE				
MIN WALL STUD FRAMING NOMINAL SIZE AND GRADE	MAX PONY WALL HEIGHT (FEET)	MAX TOTAL WALL HEIGHT (FEET)	MAX OPENING WIDTH (FEET)	TENSION STRAP CAPACITY REQ (LBS)
115 MPH, EXP B				
2x4 #2 GRADE	0	10	18	1,000
			9	1,000
	1	10	16	1,025
			18	1,275
	2	10	9	1,000
			18	2,500
	2	12	9	1,500
			18	3,375
4	12	9	3,975	
		12	3,775	
2x6 STUD GRADE	2	12	9	1,000
			16	2,150
	4	12	9	2,550
			16	2,400
			9	1,750
			18	3,800

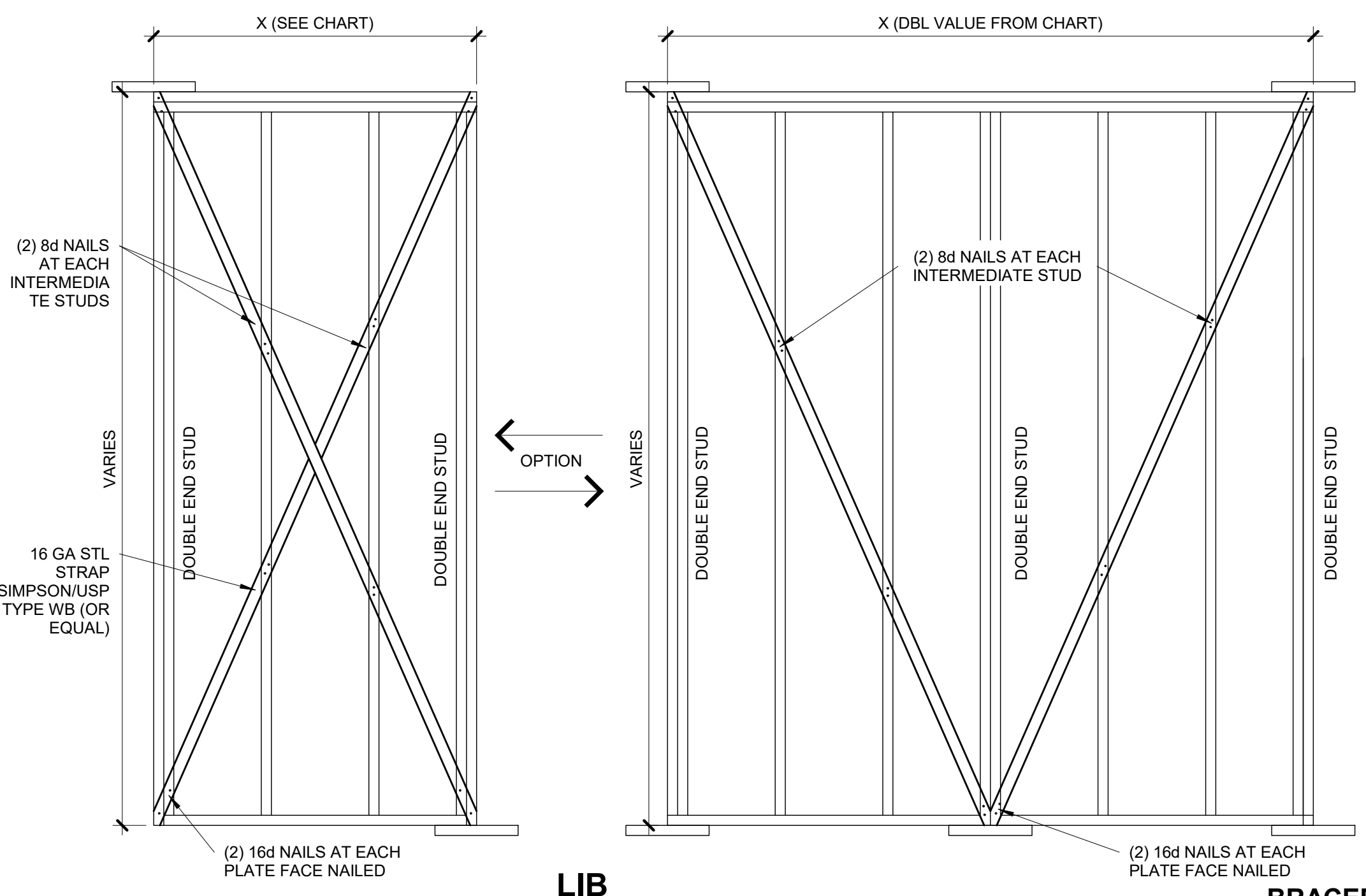

BRACED WALL PANEL SCHEDULE

WALL HEIGHT	MIN WALL LENGTH (X)	MAX WALL LENGTH (X)
8'-0"	4'-7"	8'-0"
9'-0"	5'-2"	9'-0"
10'-0"	5'-9"	10'-0"
11'-0"	NP	-
12'-0"	NP	-

NOTE: BRACED WALL PANEL LENGTHS BASED ON WALL HEIGHT FOR IRC, LIB

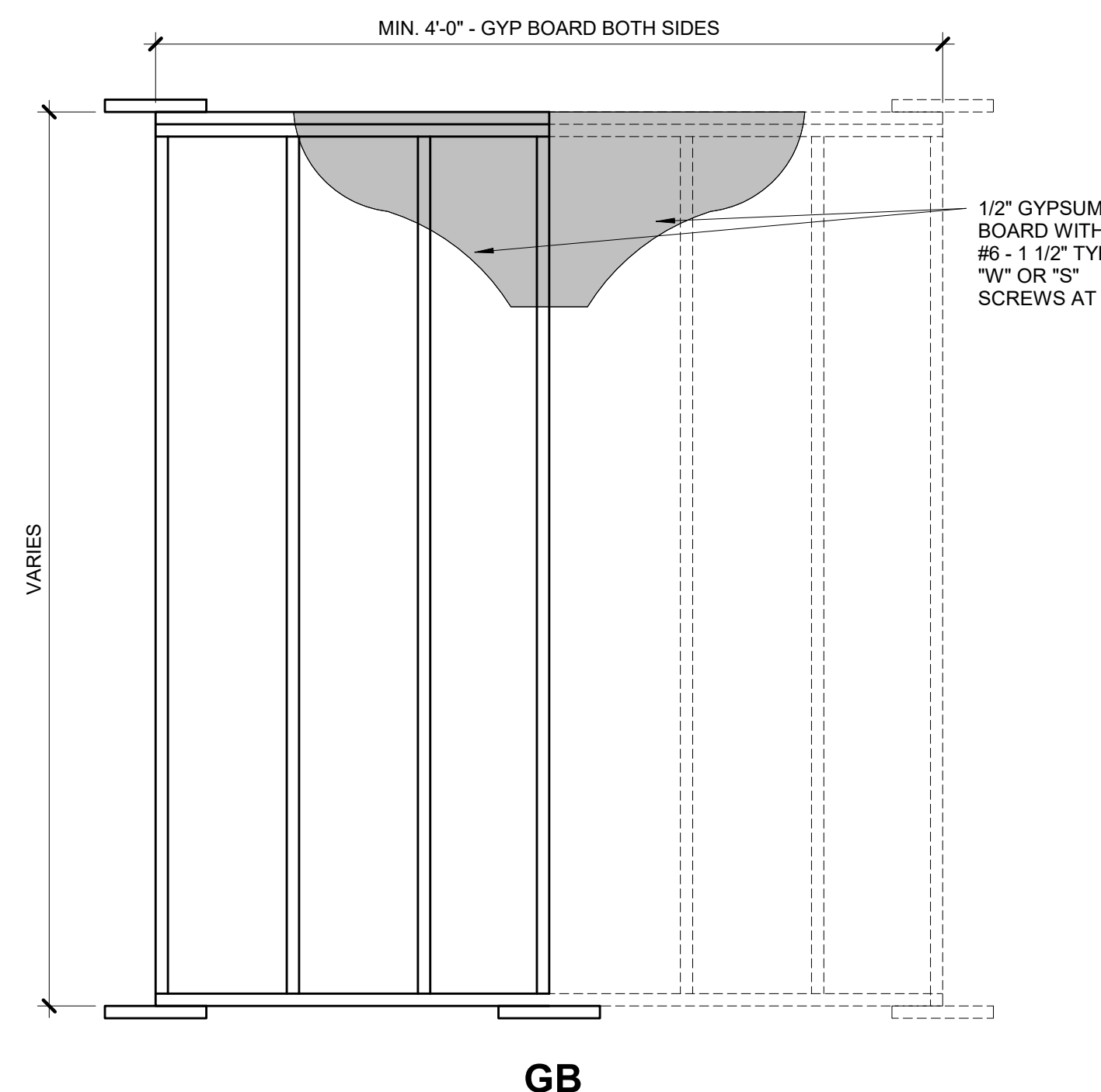

LIB
2 BRACED WALL PANEL-IRC METHODS LIB AND GB
S4.0 3/4" = 1'-0"

BRACED WALL METHODOLOGY
CONTINUOUS EXTERIOR SHEATHING (CS-WSP) PER WSP METHOD (BELOW) UNLESS OTHERWISE NOTED ON THE PLAN

XXXX EXTERIOR BRACED WALLS:
WSP METHOD:
WOOD STRUCTURAL PANEL SHEATHING WITH A THICKNESS NOT LESS THAN 3/8" WITH MINIMUM SPAN RATING OF 2400 FOR 16" OC STUD SPACING WITH 6d COMMON NAILS AT 6" OC EDGES AND 12" OC FIELD OR SHEATHING THICKNESS NOT LESS THAN 7/16" WITH MINIMUM SPAN RATING OF 2416 FOR 24" OC SPACING WITH 8d COMMON NAILS AT 6" OC EDGES AND 12" OC IN FIELD.
(NOTE: FRAMING MEMBERS 16" OC MAX UNBLOCKED, AND WITH SHEATHING APPLIED DIRECTLY TO FRAMING MEMBERS)

///// INTERIOR BRACED WALLS (REF 2/S4.0):
GB METHOD:
1/2" MIN GYPSUM BOARD OVER STUDS SPACED 24" MAX FASTENED WITH #6 - 1 1/4" TYPE "W" OR "S" DRYWALL SCREWS AT 7" OC EDGES AND FIELD (MIN. 4'-0" SECTION FOR BOTH SIDES.)
OR
LIB METHOD:
1x4 WOOD FASTENED WITH (3) 8d COMMON NAILS OR SIMPSON / USP 16 GA TYPE WB (OR EQUAL) STL X-BRACE(S) AT 45° TO 60° ANGLES, MAXIMUM 16" OC STUD FASTENED PER MANUFACTURER'S SPECIFICATIONS.

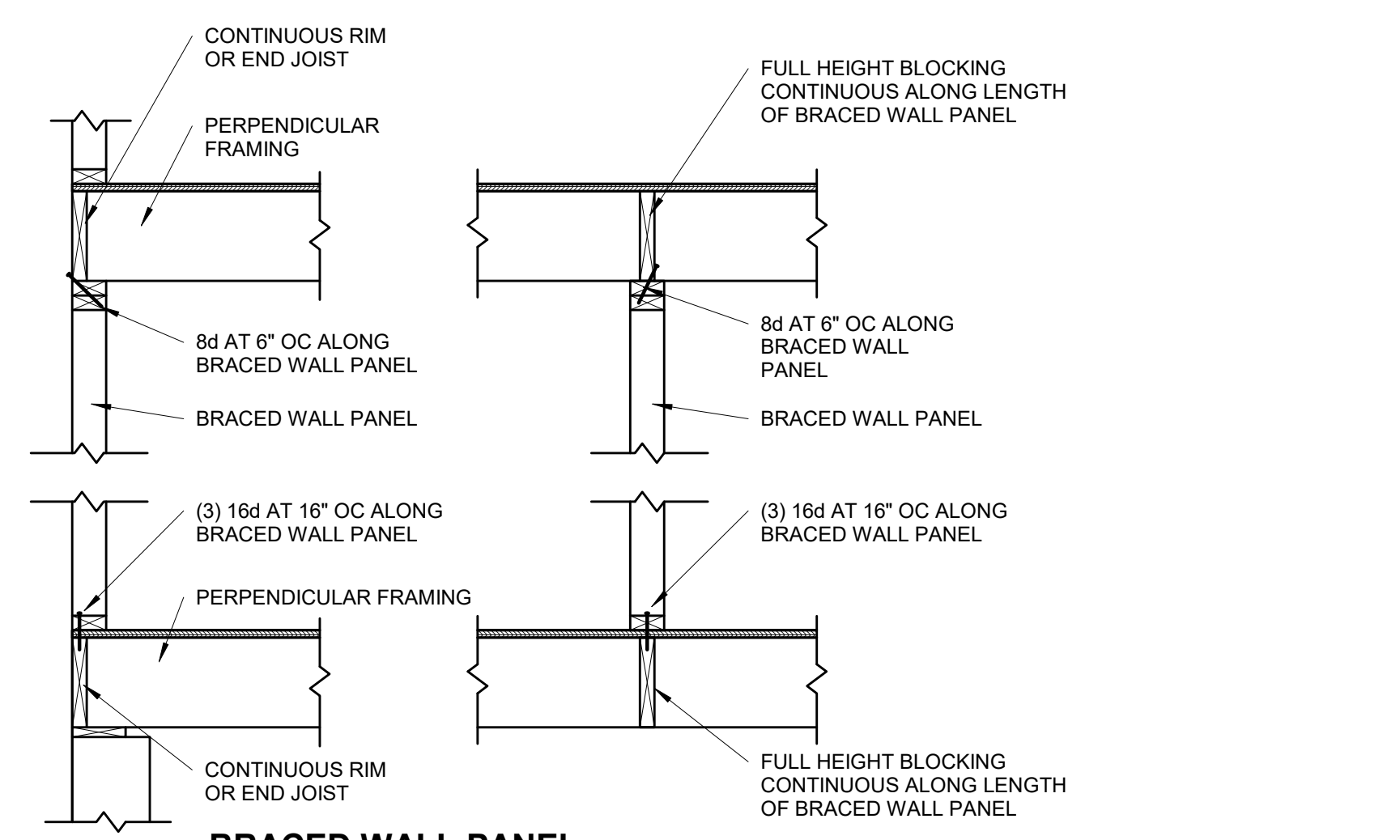

BRACED WALL PANEL CONNECTION WHEN PERPENDICULAR TO FLOOR/CEILING FRAMING

S4.1 3/4" = 1'-0"

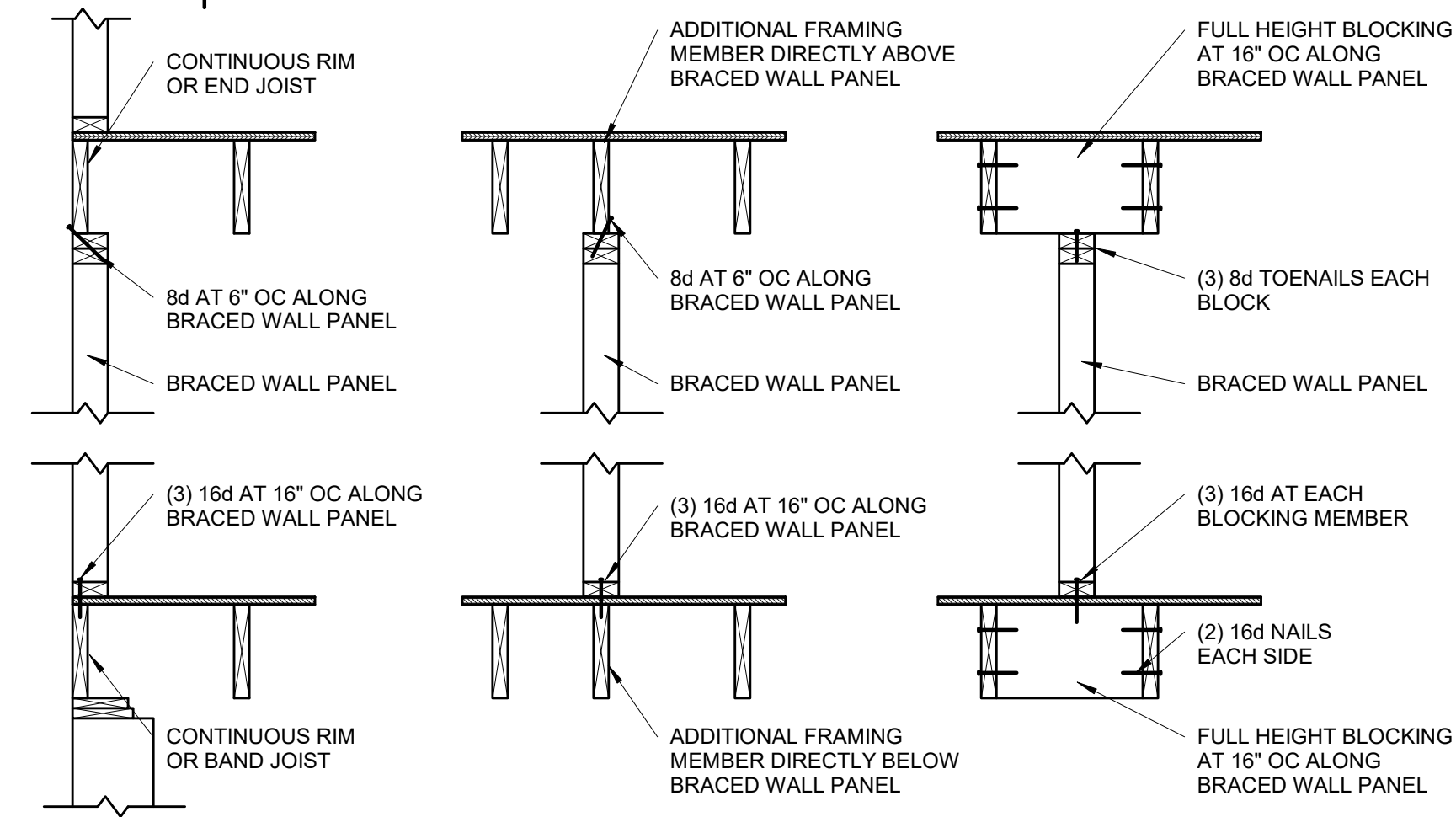

BRACED WALL PANEL CONNECTION WHEN PARALLEL TO FLOOR/CEILING FRAMING

S4.1 3/4" = 1'-0"

CONT. SHEATHED BRACED WALL END CONDITIONS

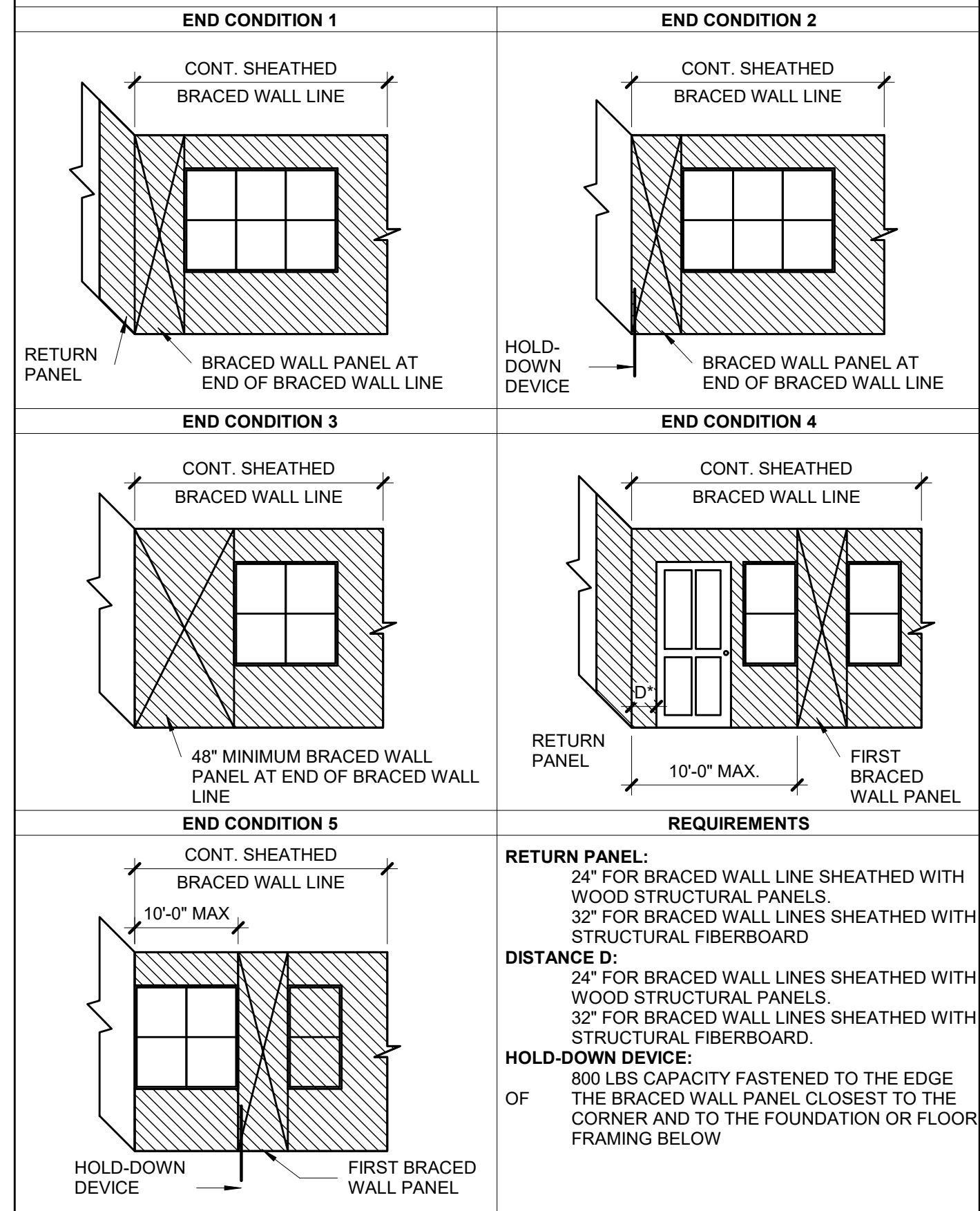

CONTINUOUS SHEATHED BRACED WALL END CONDITIONS

S4.1 NOT TO SCALE. (COMPLIANCE WITH IRC R602.10.7)

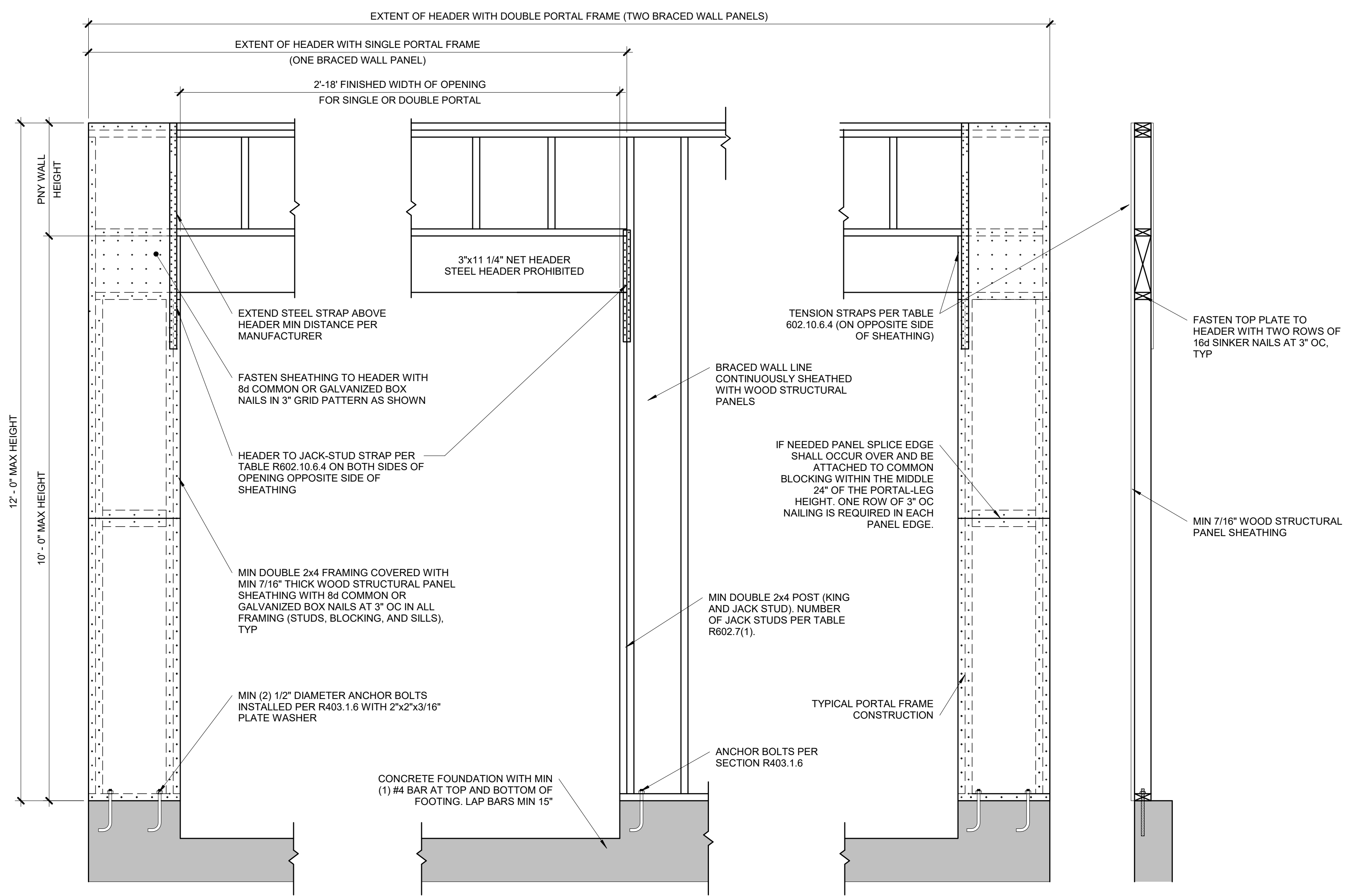

OVER CONCRETE OR MASONRY BLOCK FOUNDATION

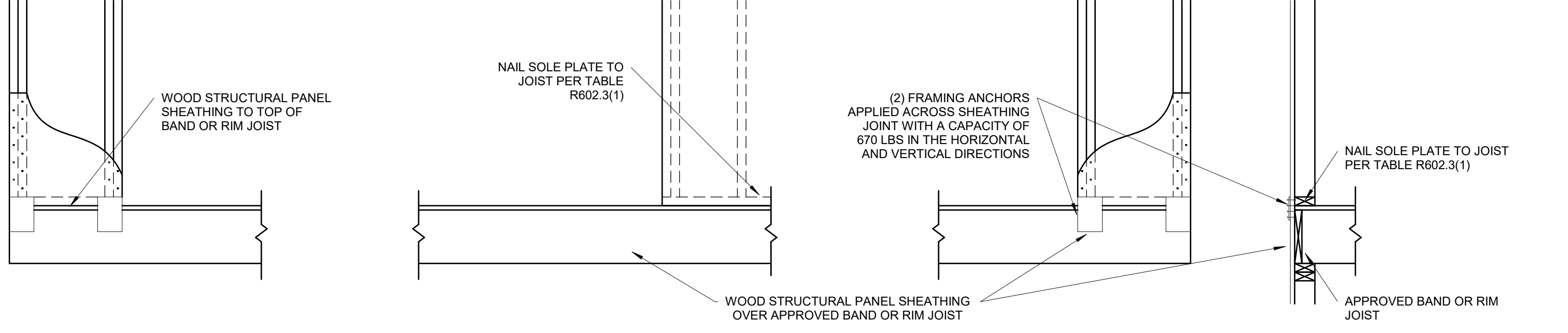

OVER RAISE WOOD FLOOR - FRAMING ANCHOR OPTION

(WHEN PORTAL SHEATHING DOES NOT LAP OVER BAND OR RIM JOIST)

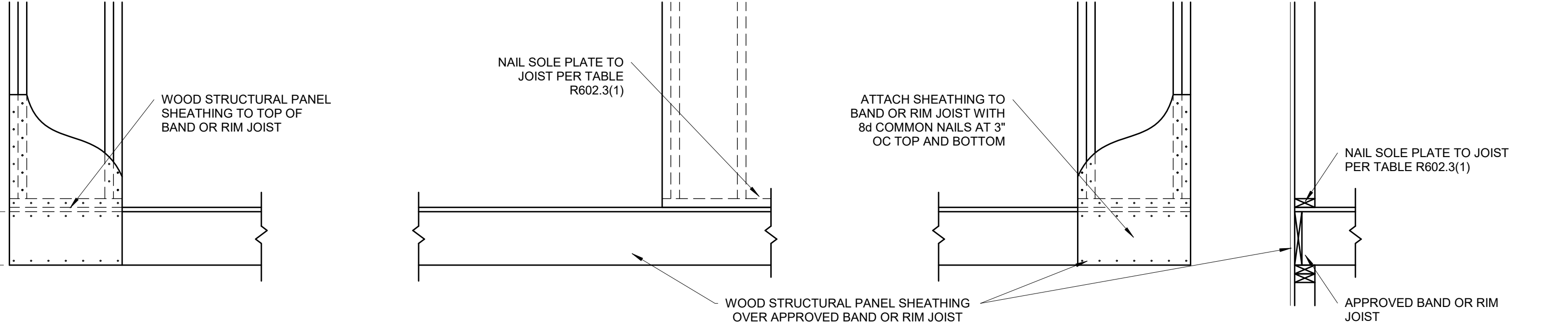

OVER RAISE WOOD FLOOR - OVERLAP OPTION

(WHEN PORTAL SHEATHING LAPS OVER BAND OR RIMBOARD)

BRACED WALL PANEL-IRC METHOD CS-PF CONTINUOUSLY SHEATHED PORTAL FRAME

1 PANEL CONSTRUCTION

S4.1 3/4" = 1'-0" (PER IRC R602.10.6.4)