

SHEET CATALOG

INDEX NO.	DESCRIPTION
T-01	COVER PAGE
S-01	MOUNTING DETAIL
S-02	STRUCTURAL DETAIL
S-03	ROOF FRAMING DETAILS-1
S-04	ROOF FRAMING DETAILS-2
E-01	SINGLE LINE DIAGRAM
PL-01	WARNING PLACARDS
PL-02	ROOF ACCESS POINT
SS	SPEC SHEET(S)

SCOPE OF WORK

GENERAL SYSTEM INFORMATION:
 SYSTEM SIZE:
 16800W DC, 13650W AC, 14.4 kWh ENERGY STORAGE SYSTEM
 MODULES:
 (42) REC SOLAR REC400NP3 BLACK (400W)
 INVERTER:
 (42) ENPHASE IQ8M-72-2-US (240V),
 BRANCH DETAILS:
 1X11, 1X11, 1X10 & 1X10 ENPHASE BRANCH

APPLICABLE CODES

- ELECTRIC CODE: NEC 2017
- FIRE CODE: IFC 2018
- BUILDING CODE: IBC 2018
- RESIDENTIAL CODE: IRC 2018

GENERAL NOTES

1. MODULES ARE LISTED UNDER UL 1703/61730 AND CONFORM TO THE STANDARDS.
2. INVERTERS ARE LISTED UNDER UL 1741 AND CONFORM TO THE STANDARDS.
3. DRAWINGS ARE DIAGRAMMATIC, INDICATING GENERAL ARRANGEMENT OF THE PV SYSTEM AND THE ACTUAL SITE CONDITION MIGHT VARY.
4. WORKING CLEARANCES AROUND THE NEW PV ELECTRICAL EQUIPMENT WILL BE MAINTAINED IN ACCORDANCE WITH NEC 110.26.
5. ALL GROUND WIRING CONNECTED TO THE MAIN SERVICE GROUNDING IN MAIN SERVICE PANEL/ SERVICE EQUIPMENT.
6. ALL CONDUCTORS SHALL BE 600V, 90°C STANDARD COPPER UNLESS OTHERWISE NOTED.
7. WHEN REQUIRED, A LADDER SHALL BE IN PLACE FOR INSPECTION IN COMPLIANCE WITH OSHA REGULATIONS.
8. THE SYSTEM WILL NOT BE INTERCONNECTED BY THE CONTRACTOR UNTIL APPROVAL FROM THE LOCAL JURISDICTION AND/OR THE UTILITY.
9. ROOF ACCESS POINT SHALL BE LOCATED IN AREAS THAT DO NOT REQUIRE THE PLACEMENT OF GROUND LADDERS OVER OPENINGS SUCH AS WINDOWS OR DOORS, AND LOCATED AT STRONG POINTS OF BUILDING CONSTRUCTION WHERE THE ACCESS POINT DOES NOT CONFLICT WITH OVERHEAD OBSTRUCTIONS SUCH AS TREES, WIRES OR SIGNS.
10. PV ARRAY COMBINER/JUNCTION BOX PROVIDES TRANSITION FROM ARRAY WIRING TO CONDUIT WIRING

JEFFREY BRANDHORST - 16.800kW DC, 13.650kW AC

SITE PLAN LAYOUT

TOTAL AREA OF ROOF (SQ.FT)	2937
TOTAL ARRAY AREA (SQ.FT)	892.3017
TOTAL AREA OF ARRAY COVERED IN THE ROOF (%)	30.38

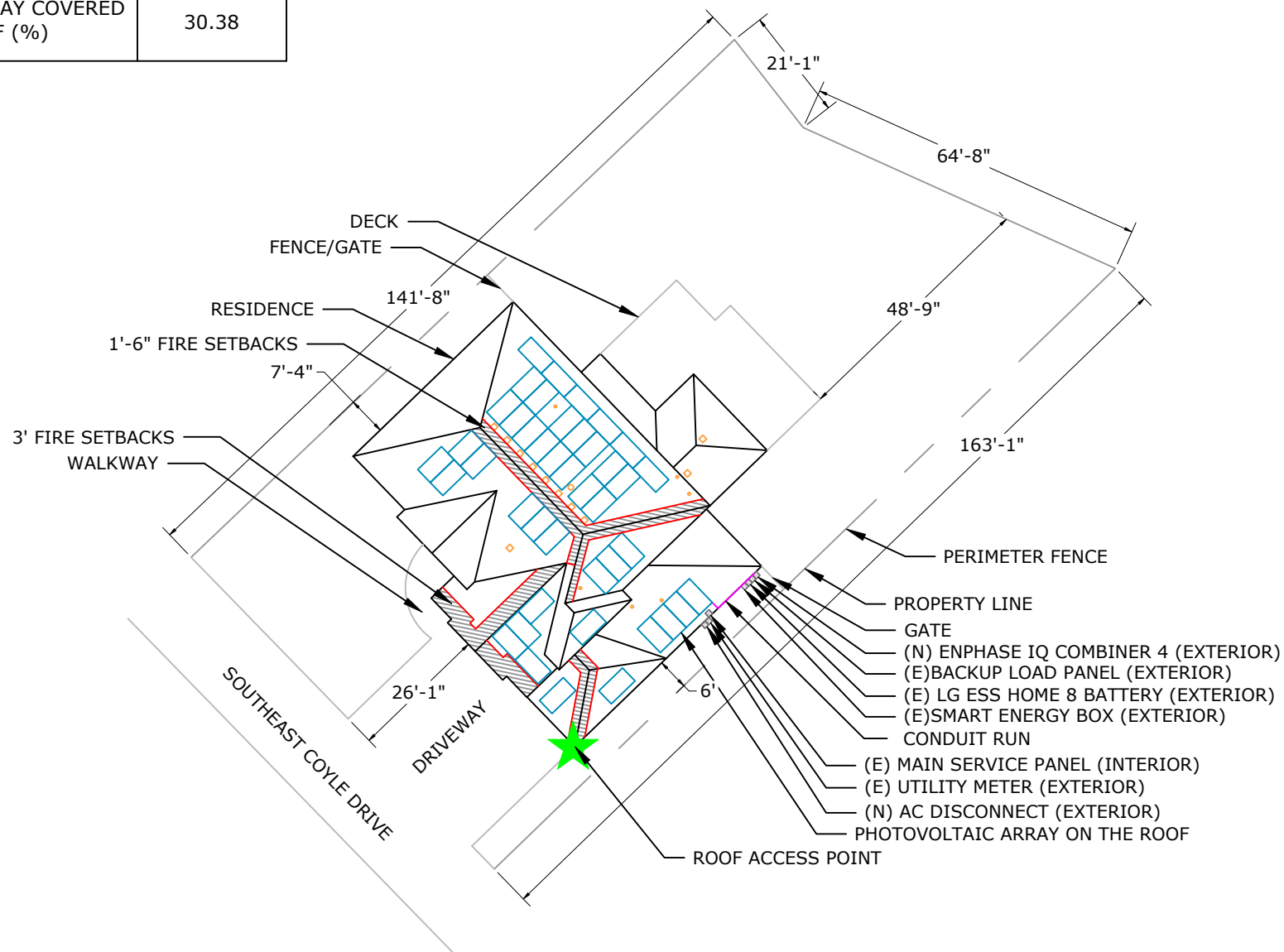

SCALE: 1"=30'-0"

ENGINEERING SCOPE OF WORK

1. ILLUMINE INDUSTRIES INC. HAS ONLY PROVIDED DRAFTING SERVICES FOR THE PERMIT DRAWINGS. NO ACTUAL ENGINEERING WORK, ENGINEERING REVIEW OR ENGINEERING APPROVAL HAS BEEN CONDUCTED BY ILLUMINE INDUSTRIES INC UNLESS NOTED OTHERWISE.
2. WHEN A PROFESSIONAL ENGINEER APPROVES AND SEALS THE DESIGN FOR COMPONENTS OF THEIR RESPECTIVE DISCIPLINE (STRUCTURAL/ ELECTRICAL) SHOWN ON THESE PERMIT DRAWINGS, HE/SHE:
 - a. TAKES FULL DIRECT CONTROL OF THE ENGINEERED DESIGN
 - b. IS GIVEN ACCESS TO PERSONALLY SUPERVISE AND RECTIFY ANY ASPECT OF THE ENGINEERED DESIGN
 - c. HAS FULLY ACCEPTED RESPONSIBILITY FOR THE ENGINEERED DESIGN

VICINITY MAP

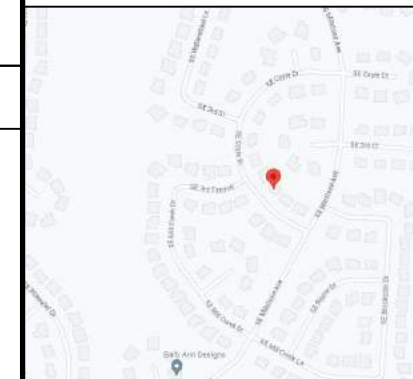

CUSTOMER INFORMATION

NAME: JEFFREY BRANDHORST
 ADDRESS: 257 SOUTHEAST COYLE DRIVE, LEE'S SUMMIT, MO 64063
 38.911451, -94.306996
 APN: 60240171300000000
 AHJ: MO-CITY OF LEE'S SUMMIT
 UTILITY: KCPL-M
 PRN NUMBER: RGS-88302



COVER PAGE

DRAFTED BY: B.PATIL	PAPER SIZE: 17"X11"
QC'ED BY: D.XAVIER	
SCALE: AS NOTED	REV: E
DATE: 12/1/2023	T-01

INSTALLATION NOTES

1. STRUCTURAL ROOF MEMBER LOCATIONS ARE ESTIMATED AND SHOULD BE LOCATED AND VERIFIED BY THE CONTRACTOR WHEN LAG BOLT PENETRATION OR MECHANICAL ATTACHMENT TO THE STRUCTURE IS REQUIRED.

2. ROOFTOP PENETRATIONS FOR SOLAR RACKING WILL BE COMPLETED AND SEALED WITH APPROVED SEALANT PER CODE BY A LICENSED CONTRACTOR.

3. LAGS MUST HAVE A MINIMUM 2.5" THREAD EMBEDMENT INTO THE STRUCTURAL MEMBER.

4. ALL PV RACKING ATTACHMENTS SHALL BE STAGGERED BY ROW BETWEEN THE ROOF FRAMING MEMBERS AS NECESSARY.

5. ROOF MOUNTED STANDARD RAIL REQUIRES ONE THERMAL EXPANSION GAP FOR EVERY RUN OF RAIL GREATER THAN 40'.

6. ALL CONDUCTORS AND CONDUITS ON THE ROOF SHALL BE MINIMUM 7/8" ABOVE THE ROOF SURFACE (INCLUDING CABLES UNDERNEATH MODULES AND RACKING).

7. THE PV INSTALLATION SHALL NOT OBSTRUCT ANY PLUMBING, MECHANICAL OR BUILDING ROOF VENTS

ROOF ACCESS PATHWAYS AND SETBACKS:

1204.2.1 SOLAR PHOTOVOLTAIC (PV) SYSTEMS FOR GROUP R-3 BUILDINGS

SOLAR PHOTOVOLTAIC (PV) SYSTEMS FOR GROUP R-3 BUILDINGS SHALL COMPLY WITH SECTIONS 1204.2.1.1 THROUGH 1204.2.1.3.

EXCEPTIONS:

1. THESE REQUIREMENTS SHALL NOT APPLY TO STRUCTURES DESIGNED AND CONSTRUCTED IN ACCORDANCE WITH THE INTERNATIONAL RESIDENTIAL CODE.

2. THESE REQUIREMENTS SHALL NOT APPLY TO ROOFS WITH SLOPES OF 2 UNITS VERTICAL IN 12 UNITS HORIZONTAL OR LESS.

1204.2.1.1 PATHWAYS TO RIDGE

NOT FEWER THAN TWO 36-INCH-WIDE (914 MM) PATHWAYS ON SEPARATE ROOF PLANES, FROM LOWEST ROOF EDGE TO RIDGE, SHALL BE PROVIDED ON ALL BUILDINGS. NOT FEWER THAN ONE PATHWAY SHALL BE PROVIDED ON THE STREET OR DRIVEWAY SIDE OF THE ROOF. FOR EACH ROOF PLANE WITH A PHOTOVOLTAIC ARRAY, NOT FEWER THAN ONE 36-INCH-WIDE (914 MM) PATHWAY FROM LOWEST ROOF EDGE TO RIDGE SHALL BE PROVIDED ON THE SAME ROOF PLANE AS THE PHOTOVOLTAIC ARRAY, ON AN ADJACENT ROOF PLANE OR STRADDLING THE SAME AND ADJACENT ROOF PLANES.

1204.2.1.2 SETBACKS AT RIDGE

FOR PHOTOVOLTAIC ARRAYS OCCUPYING 33 PERCENT OR LESS OF THE PLAN VIEW TOTAL ROOF AREA, A SETBACK OF NOT LESS THAN 18 INCHES (457 MM) WIDE IS REQUIRED ON BOTH SIDES OF A HORIZONTAL RIDGE. FOR PHOTOVOLTAIC ARRAYS OCCUPYING MORE THAN 33 PERCENT OF THE PLAN VIEW TOTAL ROOF AREA, A SETBACK OF NOT LESS THAN 36 INCHES (457 MM) WIDE IS REQUIRED ON BOTH SIDES OF A HORIZONTAL RIDGE.

1204.2.1.3 ALTERNATIVE SETBACKS AT RIDGE

WHERE AN AUTOMATIC SPRINKLER SYSTEM IS INSTALLED WITHIN THE DWELLING IN ACCORDANCE WITH SECTION 903.3.1.3, SETBACKS AT THE RIDGE SHALL CONFORM TO ONE OF THE FOLLOWING:

1. FOR PHOTOVOLTAIC ARRAYS OCCUPYING 66 PERCENT OR LESS OF THE PLAN VIEW TOTAL ROOF AREA, A SETBACK OF NOT LESS THAN 18 INCHES (457 MM) WIDE IS REQUIRED ON BOTH SIDES OF A HORIZONTAL RIDGE.

2. FOR PHOTOVOLTAIC ARRAYS OCCUPYING MORE THAN 66 PERCENT OF THE PLAN VIEW TOTAL ROOF AREA, A SETBACK OF NOT LESS THAN 36 INCHES (914 MM) WIDE IS REQUIRED ON BOTH SIDES OF A HORIZONTAL RIDGE.

1204.2.2 EMERGENCY ESCAPE AND RESCUE OPENINGS

PANELS AND MODULES INSTALLED ON GROUP R-3 BUILDINGS SHALL NOT BE PLACED ON THE PORTION OF A ROOF THAT IS BELOW AN EMERGENCY ESCAPE AND RESCUE OPENING. A PATHWAY OF NOT LESS THAN 36 INCHES (914 MM) WIDE SHALL BE PROVIDED TO THE EMERGENCY ESCAPE AND RESCUE OPENING.

SITE INFORMATION - WIND SPEED: 109 MPH AND SNOW LOAD: 20 PSF

SR. NO	AZIMUTH	PITCH	NO. OF MODULES	ARRAY AREA (SQ. FT.)	ROOF TYPE	ATTACHMENT	ROOF EXPOSURE	FRAME TYPE	FRAME SIZE	FRAME SPACING	MAX RAIL SPAN	OVER HANG
MP-01	46°	30°	21	446.2	COMPOSITION SHINGLE	QUICKMOUNT HALO ULTRAGRIP	ATTIC	PRE FABRICATED TRUSSES	2 X 4	2'-0"	4'-0"	1'-6"
MP-02	226°	30°	7	148.7	COMPOSITION SHINGLE	QUICKMOUNT HALO ULTRAGRIP	ATTIC	PRE FABRICATED TRUSSES	2 X 4	2'-0"	4'-0"	1'-6"
MP-03	136°	30°	4	85.0	COMPOSITION SHINGLE	QUICKMOUNT HALO ULTRAGRIP	ATTIC	PRE FABRICATED TRUSSES	2 X 4	2'-0"	4'-0"	1'-6"
MP-04	226°	30°	1	21.2	COMPOSITION SHINGLE	QUICKMOUNT HALO ULTRAGRIP	ATTIC	PRE FABRICATED TRUSSES	2 X 4	2'-0"	4'-0"	1'-6"
MP-05	136°	30°	1	21.2	COMPOSITION SHINGLE	QUICKMOUNT HALO ULTRAGRIP	ATTIC	PRE FABRICATED TRUSSES	2 X 4	2'-0"	4'-0"	1'-6"
MP-06	136°	30°	1	21.2	COMPOSITION SHINGLE	QUICKMOUNT HALO ULTRAGRIP	ATTIC	PRE FABRICATED TRUSSES	2 X 4	2'-0"	4'-0"	1'-6"
MP-07	136°	30°	4	85.0	COMPOSITION SHINGLE	QUICKMOUNT HALO ULTRAGRIP	ATTIC	PRE FABRICATED TRUSSES	2 X 4	2'-0"	4'-0"	1'-6"
MP-08	136°	30°	3	63.7	COMPOSITION SHINGLE	QUICKMOUNT HALO ULTRAGRIP	ATTIC	PRE FABRICATED TRUSSES	2 X 4	2'-0"	4'-0"	1'-6"

AERIAL VIEW



CUSTOMER INFORMATION

NAME: JEFFREY BRANDHORST

ADDRESS: 257 SOUTHEAST COYLE DRIVE, LEE'S SUMMIT, MO 64063

38.911451, -94.306996
APN: 6024017130000000

AHJ: MO-CITY OF LEE'S SUMMIT

UTILITY: KCPL-M

PRN NUMBER: RGS-88302



MOUNTING DETAIL

DRAFTED BY: B.PATIL
QC'ED BY: D.XAVIER

PAPER SIZE: 17"X11"

SCALE: AS NOTED

REV: E

DATE: 12/1/2023

S-01

NOTE: PENETRATIONS ARE STAGGERED

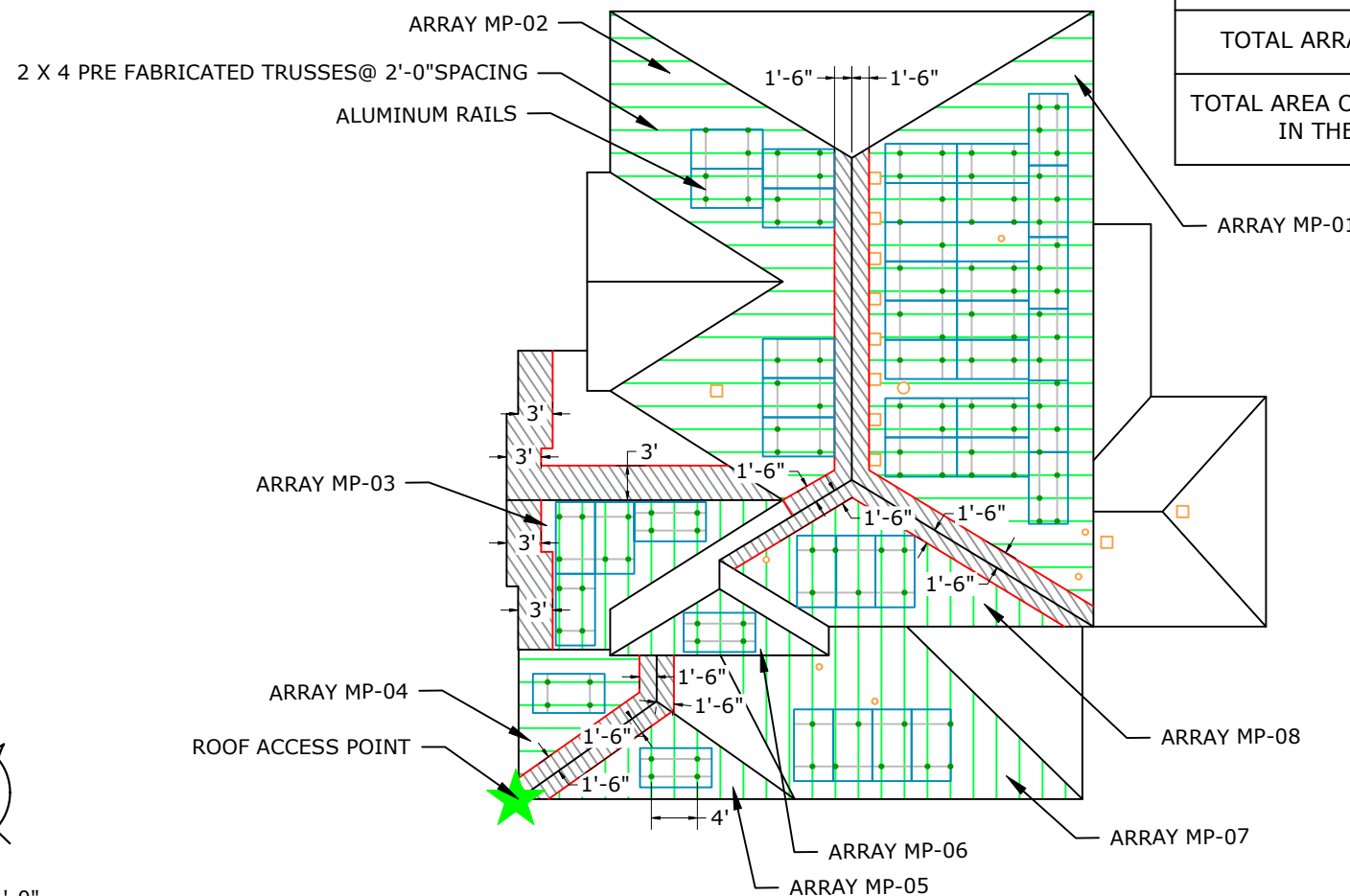

TOTAL AREA OF ROOF (SQ.FT)	2937
TOTAL ARRAY AREA (SQ.FT)	892.3017
TOTAL AREA OF ARRAY COVERED IN THE ROOF (%)	30.38



SCALE: 1/16" = 1'-0"

DEAD LOAD CALCULATIONS			
BOM	QUANTITY	LBS/UNIT	TOTAL WEIGHT (LBS)
MODULES	42	48	2016.00
MID-CLAMP	50	0.050	2.50
END-CLAMP	68	0.050	3.40
RAIL LENGTH	348	0.680	236.64
SPLICE BAR	8	0.360	2.88
QUICKMOUNT HALO ULTRAGRIP	119	0.57	67.83
MICROINVERTERS	42	2.38	99.96
TOTAL WEIGHT OF THE SYSTEM (LBS)			2429.21
TOTAL ARRAY AREA ON THE ROOF (SQ. FT.)			892.30
WEIGHT PER SQ. FT.(LBS)			2.72
WEIGHT PER PENETRATION (LBS)			20.41

MID-CLAMP AND END-CLAMP ANATOMY

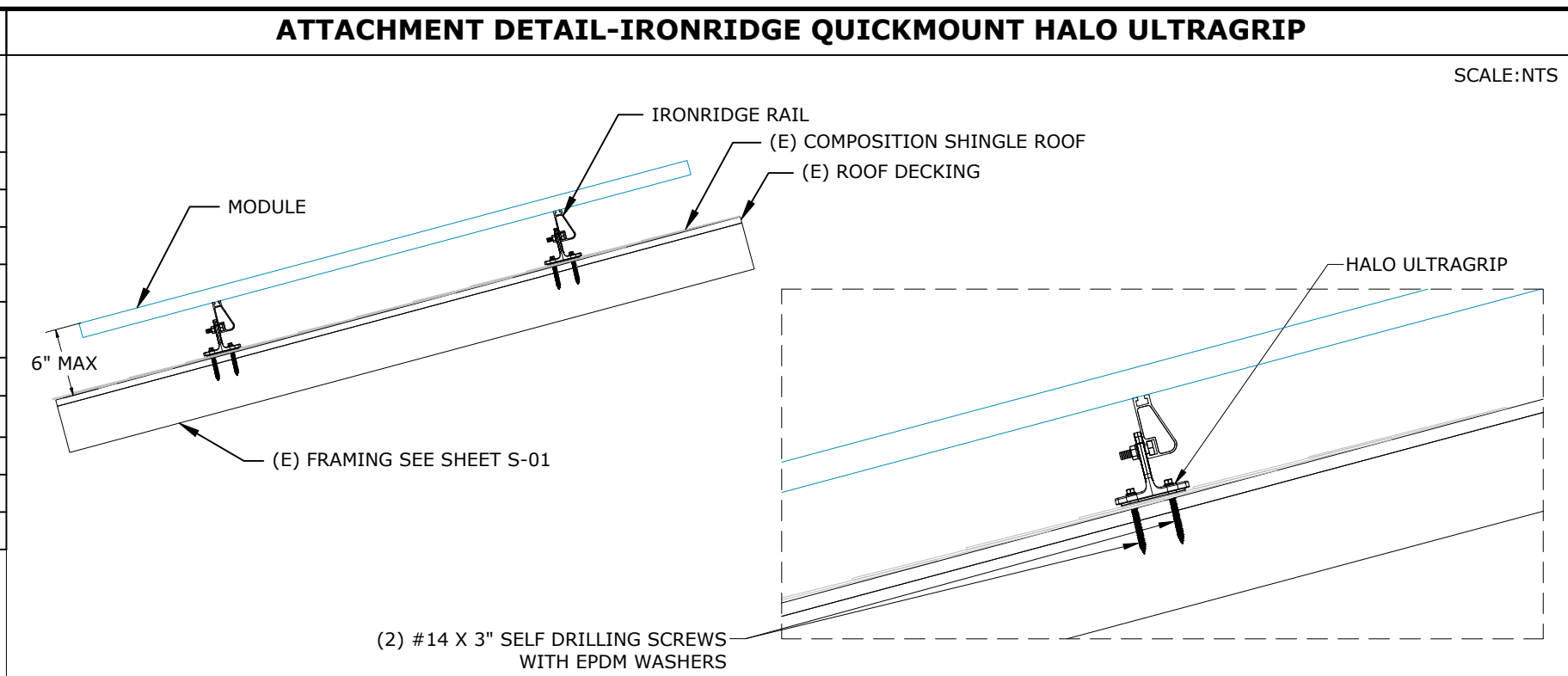
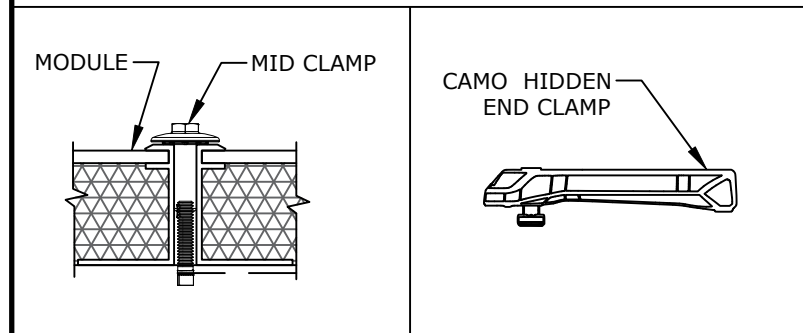

MODULES DATA	
REC SOLAR REC400NP3 BLACK (400W)	
MODULE DIMS	74.8"x40.9"x1.2"
SELF DRILLING SCREW	#14 X 3" SELF DRILLING SCREWS WITH EPDM WASHERS



CUSTOMER INFORMATION

NAME:JEFFREY BRANDHORST

ADDRESS:257 SOUTHEAST COYLE DRIVE, LEE'S SUMMIT, MO 64063

38.911451, -94.306996
APN: 60240171300000000

AHJ:MO-CITY OF LEE'S SUMMIT

UTILITY:KCPL-M

PRN NUMBER:RGS-88302



STRUCTURAL DETAIL

DRAFTED BY: B.PATIL QC'ED BY:D.XAVIER	PAPER SIZE:17"X11"
SCALE:AS NOTED	REV:E
DATE:12/1/2023	S-02

GROUNDING DETAILS

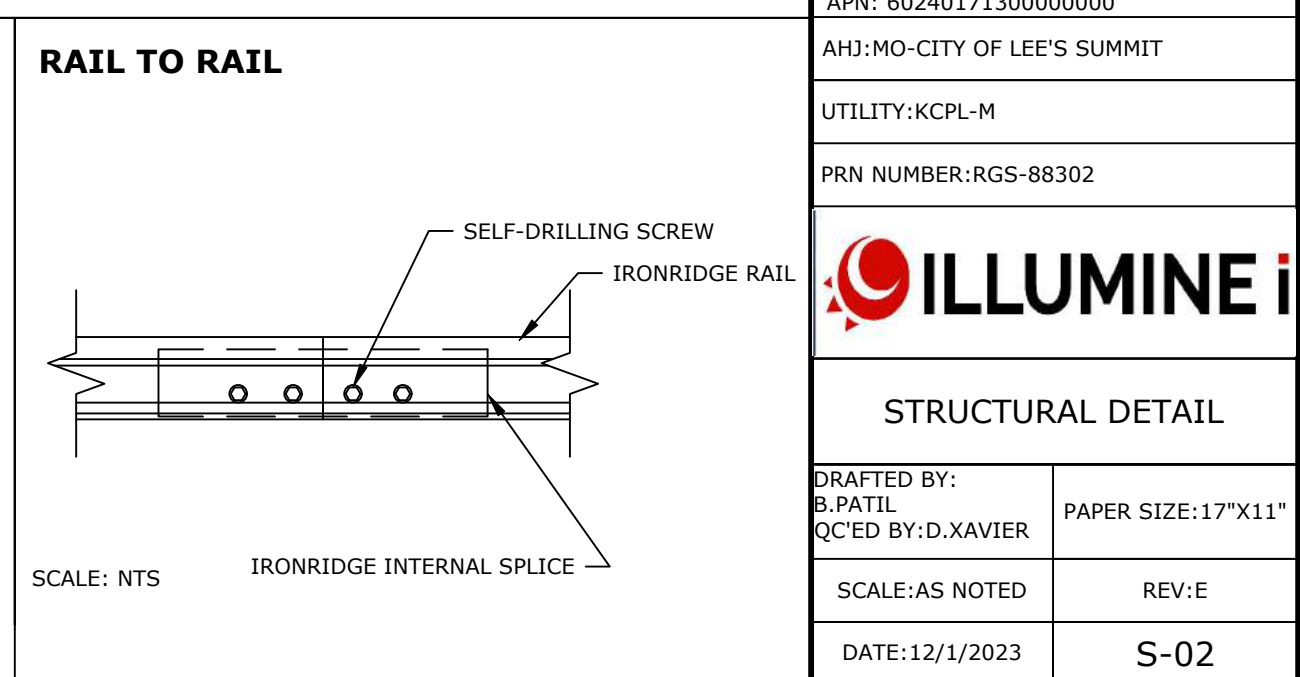
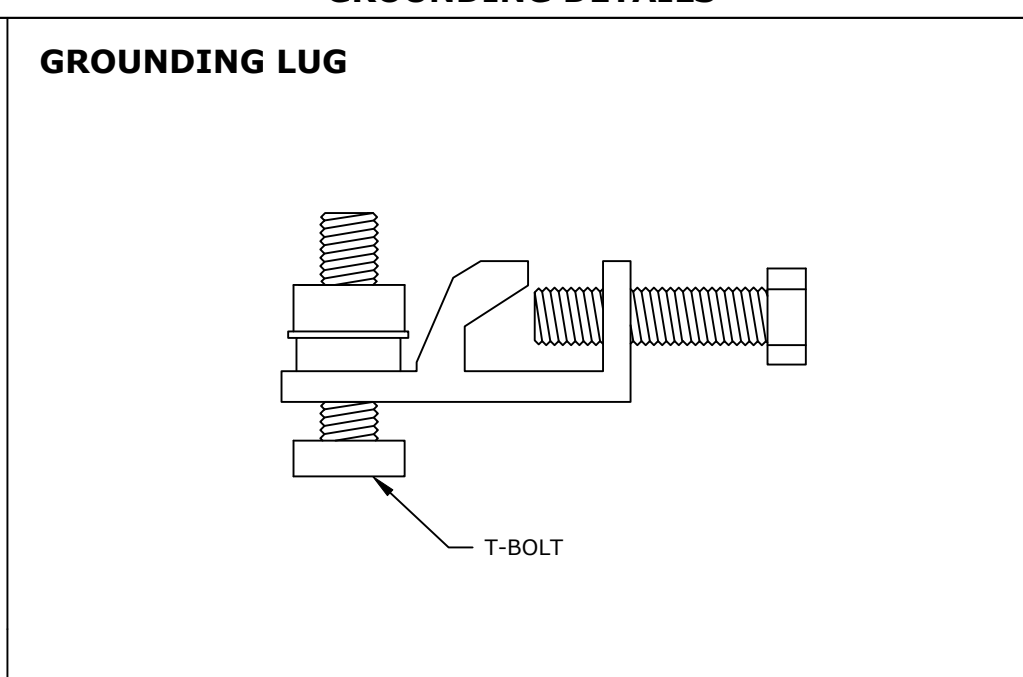
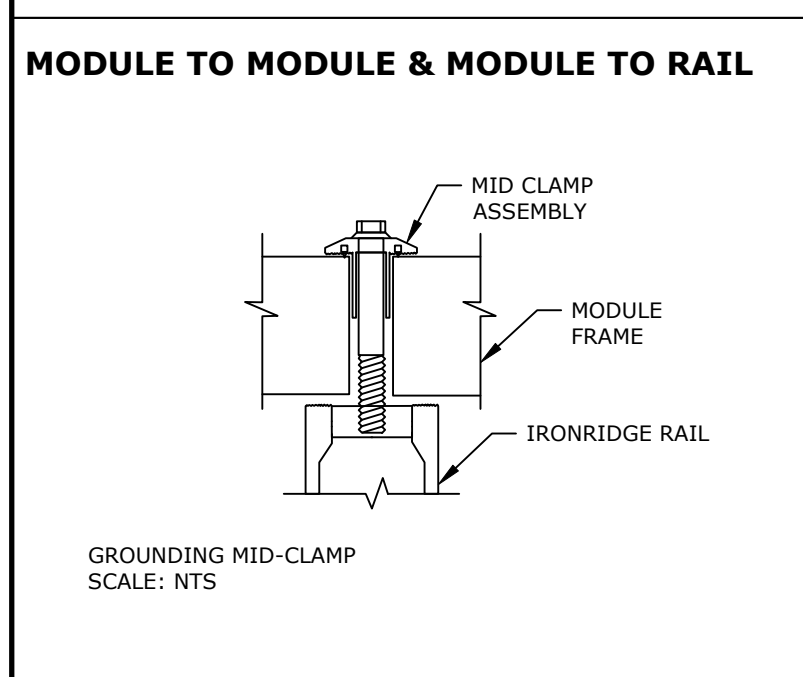

ROOF FRAMING DETAILS

MP-01,MP-02,MP-08:

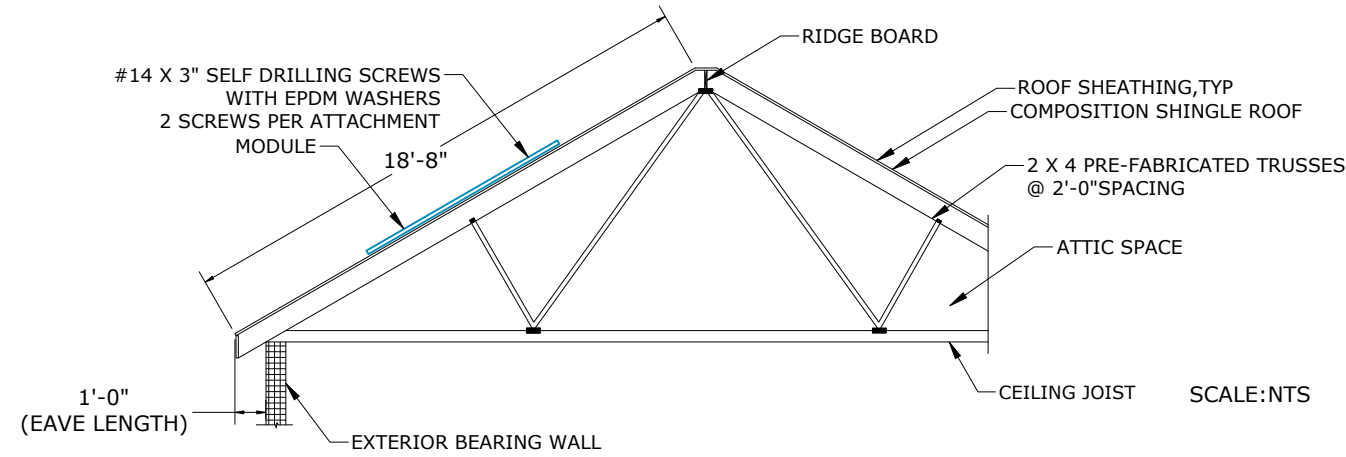

MP-03:

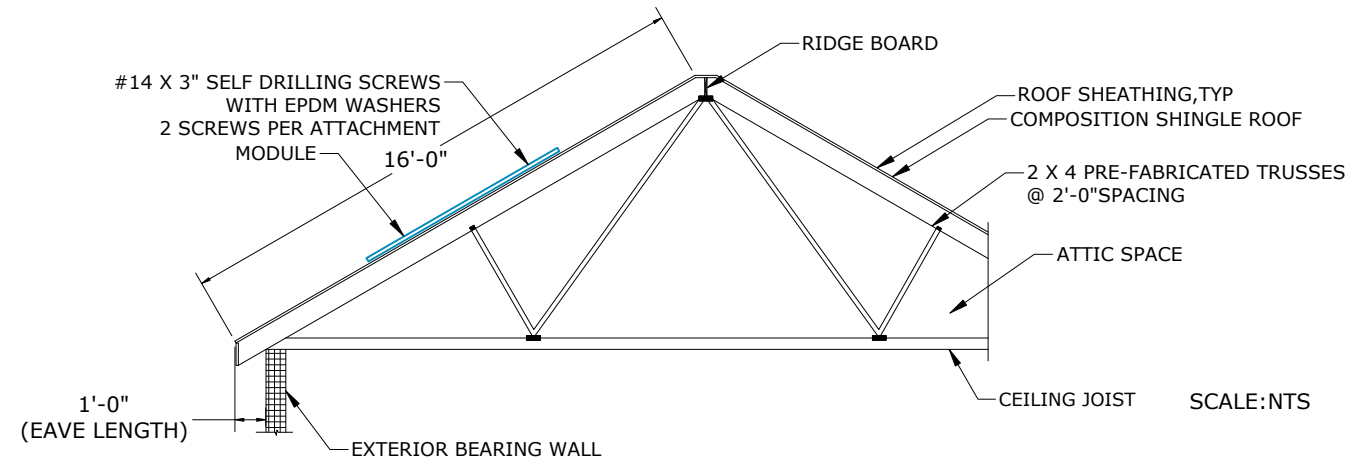

CUSTOMER INFORMATION

NAME: JEFFREY BRANDHORST

ADDRESS: 257 SOUTHEAST COYLE DRIVE,
LEE'S SUMMIT, MO 64063

38.911451, -94.306996
APN: 60240171300000000

AHJ: MO-CITY OF LEE'S SUMMIT

UTILITY: KCPL-M

PRN NUMBER: RGS-88302



ROOF FRAMING DETAILS-1

DRAFTED BY: B.PATIL	PAPER SIZE: 17"X11"
QC'ED BY: D.XAVIER	

SCALE: AS NOTED	REV: E
-----------------	--------

DATE: 12/1/2023	S-03
-----------------	------

ROOF FRAMING DETAILS

MP-04, MP-05, MP-06:

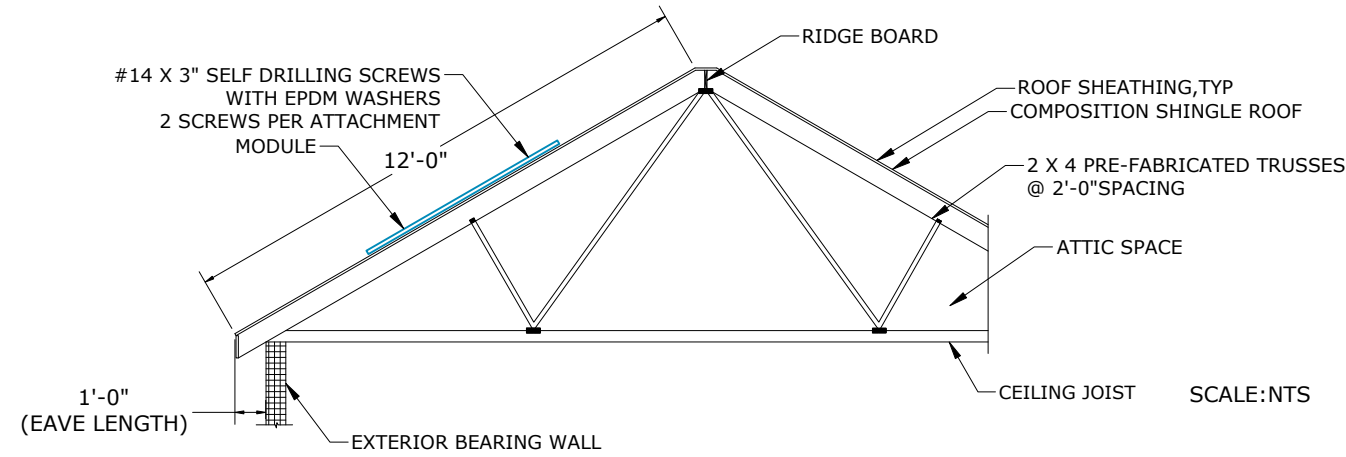

MP-07:

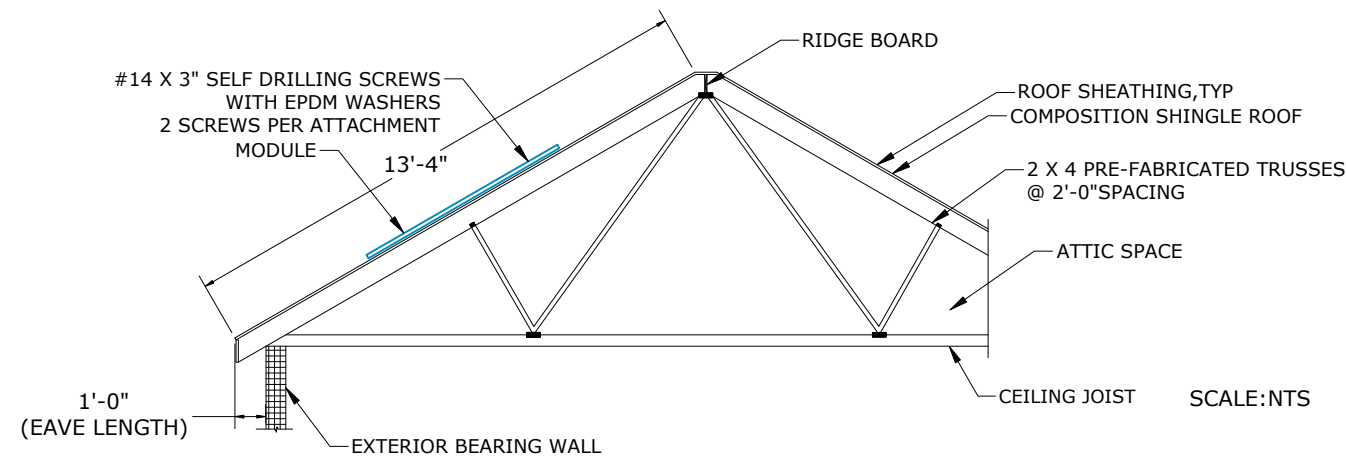

CUSTOMER INFORMATION

NAME: JEFFREY BRANDHORST

ADDRESS: 257 SOUTHEAST COYLE DRIVE,
LEE'S SUMMIT, MO 64063

38.911451, -94.306996
APN: 60240171300000000

AHJ: MO-CITY OF LEE'S SUMMIT

UTILITY: KCPL-M

PRN NUMBER: RGS-88302



ROOF FRAMING DETAILS-2

DRAFTED BY: B.PATIL QC'ED BY: D.XAVIER	PAPER SIZE: 17"X11"
----------------------------------------------	---------------------

SCALE: AS NOTED	REV: E
-----------------	--------

DATE: 12/1/2023	S-04
-----------------	------

SINGLE LINE DIAGRAM: DC SYSTEM SIZE -

16800 W, AC SYSTEM SIZE -

13650 W

ELECTRICAL NOTES

MICROINVERTER SPECIFICATIONS	
MODEL	ENPHASE IQ8M-72-2-US (240V)
MAX CONTINUOUS OUTPUT POWER	325VA
MAX OUTPUT CURRENT	1.35A
CEC WEIGHTED EFFICIENCY	97.5%
MAX NO OF MICROINVERTERS/BRANCH	11
MAX DC VOLTAGE	60V

MODULE SPECIFICATION	
MODEL	REC SOLAR REC400NP3 BLACK (400W)
MODULE POWER @ STC	400W
OPEN CIRCUIT VOLTAGE:Voc	45.0V
MAX POWER VOLTAGE:Vmp	37.6V
SHORT CIRCUIT CURRENT:Isc	11.39A
MAX POWER CURRENT:Imp	10.64A

NOTE: EACH MICROINVERTER IS RAPID SHUTDOWN COMPLIANT
 NOTE: THE FUSED AC DISCONNECT IS TO BE LOCATED WITHIN 4 FEET OF THE TAP

- CONDUCTORS EXPOSED TO WET LOCATIONS SHALL BE SUITABLE FOR USE IN WET LOCATIONS PER NEC 310.10(C).
- CONDUCTORS EXPOSED TO SUNLIGHT SHALL BE LISTED AS SUNLIGHT RESISTANT PER NEC 310.10(D).
- MAXIMUM DC/AC VOLTAGE DROP SHALL BE NO MORE THAN 2%.
- ALL CONDUCTORS SHALL BE IN CONDUIT UNLESS OTHERWISE NOTED.
- BREAKER/FUSE SIZED ACCORDING PER NEC ARTICLE 240.
- AC EQUIPMENT GROUNDING CONDUCTOR SIZED PER GEC 250.66.
- EQUIPMENT GROUNDING CONDUCTOR (EGC) SIZED PER NEC 250.122.
- AMBIENT TEMPERATURE ADJUSTMENT FACTOR IS BASED ON NEC 310.15(B)(2).
- CURRENT CARRYING CONDUCTOR ADJUSTMENT FACTOR IS BASED ON NEC 310.15(B)(3).
- MAX.SYSTEM VOLTAGE CORRECTION IS PER NEC 690.7.
- CONDUCTORS ARE SIZED PER NEC TABLE 310.15(B)(16).

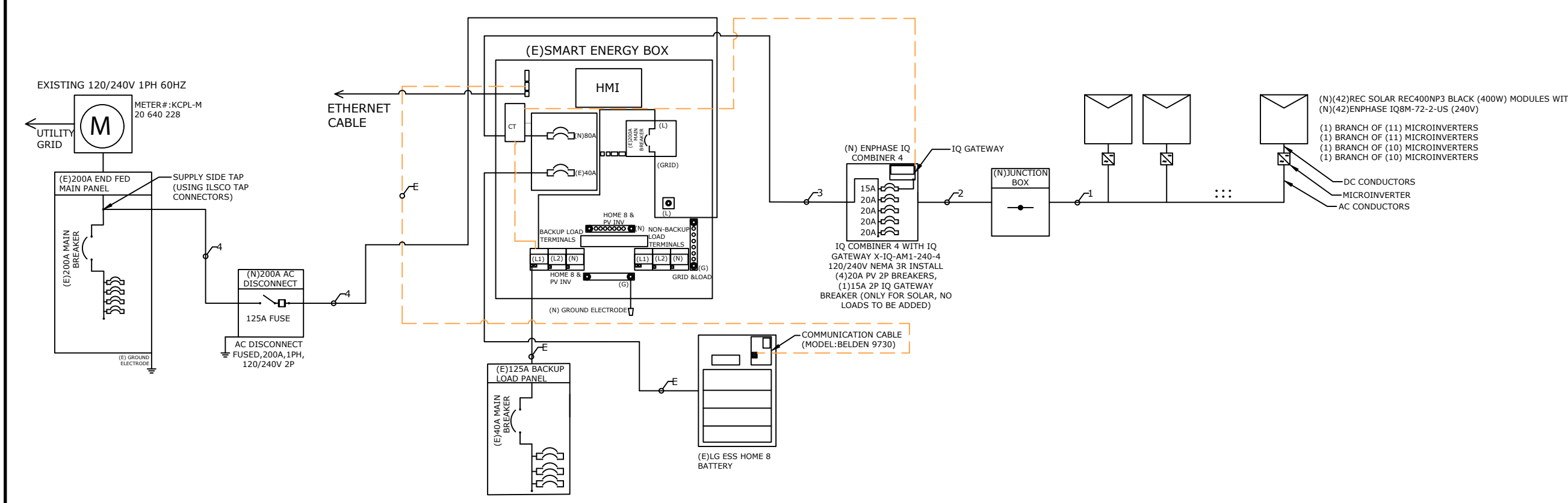

CUSTOMER INFORMATION

NAME: JEFFREY BRANDHORST
 ADDRESS: 257 SOUTHEAST COYLE DRIVE, LEE'S SUMMIT, MO 64063
 38.911451, -94.306996
 APN: 6024017130000000
 AHJ: MO-CITY OF LEE'S SUMMIT
 UTILITY: KCPL-M
 PRN NUMBER: RGS-88302

CONDUIT SCHEDULE				
TAG ID	CONDUIT SIZE	CONDUCTOR	NEUTRAL	GROUND
1	NONE	(2) 12 AWG ENPHASE Q CABLE PER BRANCH CIRCUIT	NONE	(1) 6 AWG BARE COPPER
2	1"EMT	(8) 10 AWG THWN-2	NONE	(1) 10 AWG THWN-2
3	1"EMT	(2) 4 AWG THWN-2	(1) 4 AWG THWN-2	(1) 8 AWG THWN-2
4	2"EMT	(2) 2 AWG THWN-2	(1) 2 AWG THWN-2	NONE

NOTE: MAIN PANEL RATING: 200A, MAIN BREAKER RATING: 200A
 LINE SIDE TAP: 100% ALLOWABLE BACKFEED IS = 200A
 OCPD CALCULATIONS:
 OVERCURRENT PROTECTION = (INVERTER O/P I * CONTINUOUS LOAD(1.25) * # OF INVERTERS) + (BATTERY O/P I * CONTINUOUS LOAD(1.25) * # OF BATTERIES)
 = (1.35*1.25*42) + (31.25*1.25*1) = 109.94A = PV BREAKER = 200A
 TOTAL REQUIRED BREAKER SIZE / FUSE SIZE = 125A BREAKER SIZE / FUSE SIZE



ELECTRICAL CALCULATIONS

AC WIRE SIZING CALCULATIONS BASED ON THE FOLLOWING EQUATIONS >>
 REQUIRED CONDUCTOR AMPACITY: INVERTER OUTPUT CURRENT * # OF INVERTERS = MAX CURRENT PER 690.8(A)(3) * 125% = MAX CURRENT PER 690.8(B)(1)
 CORRECTED AMPACITY CALCULATIONS: DERATED CONDUCTOR AMPACITY PER 690.8(B)(2) = AMPACITY * TEMPERATURE DERATE FACTOR * CONDUIT FILL DERATE
 DERATED CONDUCTOR AMPACITY CHECK : MAX CURRENT PER 690.8(B)(1) < DERATED CONDUCTOR AMPACITY

AC WIRE CALCULATIONS:- MATERIAL: COPPER & TEMPERATURE RATING: 90°C																			
TAG ID	REQUIRED CONDUCTOR AMPACITY				CORRECTED AMPACITY CALCULATION				DERATED CONDUCTOR AMPACITY CHECK										
1	1.35	X	11	=	14.85	X	1.25	=	18.56A	30	X	0.87	X	1	=	26.10A	18.56A	<	26.10A
2	1.35	X	11	=	14.85	X	1.25	=	18.56A	40	X	0.87	X	0.7	=	24.36A	18.56A	<	24.36A
3	1.35	X	42	=	56.70	X	1.25	=	70.88A	95	X	0.87	X	1	=	82.65A	70.88A	<	82.65A

SINGLE LINE DIAGRAM

DRAFTED BY: B.PATIL
 QC'ED BY: D.XAVIER
 SCALE: AS NOTED
 DATE: 12/1/2023
 PAPER SIZE: 17"X11"
 REV: E
 E-01

WARNING PLACARD

⚠ WARNING

ELECTRIC SHOCK HAZARD

TERMINALS ON BOTH LINE AND LOAD SIDE MAY BE ENERGIZED IN THE OPEN POSITION

INSTALLED ON: AC DISCONNECT, LOAD CENTERS, COMBINER PANELS, POINT OF INTERCONNECTION.
APPLICABLE CODE(S): NEC 690.13(B)

DEDICATED PHOTOVOLTAIC SYSTEM COMBINER PANEL NO LOAD SHALL BE ADDED TO THIS PANEL

INSTALLED ON: COMBINER PANEL

SOLAR PV SYSTEM EQUIPPED WITH RAPID SHUTDOWN

TURN RAPID SHUTDOWN SWITCH TO THE "OFF" POSITION TO SHUT DOWN PV SYSTEM AND REDUCE SHOCK HAZARD IN THE ARRAY

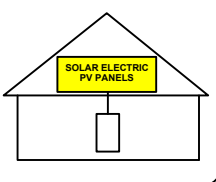

INSTALLED ON: WITHIN 3 FT OF SERVICE DISCONNECTING MEANS. MIN 3/8" BLACK TEXT ON YELLOW BACKGROUND & 3/16" BLACK TEXT ON WHITE BACKGROUND.
APPLICABLE CODE(S): NEC 690.56(C)(1)(a)

RAPID SHUTDOWN SWITCH FOR SOLAR PV SYSTEM

INSTALLED ON: MAIN SERVICE PANEL. REFLECTIVE. MIN 3/8" WHITE TEXT ON RED BACKGROUND.
APPLICABLE CODE(S): NEC 690.56(C)(3)

PHOTOVOLTAIC SYSTEM AC DISCONNECT SWITCH

RATED AC OPERATING CURRENT **56.70** AMPS AC
AC NOMINAL OPERATING VOLTAGE **240** VAC

INSTALLED ON: AC DISCONNECT(S), POINT OF INTERCONNECTION.
APPLICABLE CODE(S): NEC 690.54

⚠ WARNING ⚠
THREE POWER SOURCES
SOURCES: UTILITY GRID, BATTERY AND PV SOLAR ELECTRIC SYSTEM

INSTALLED ON: POINT OF INTERCONNECTION
APPLICABLE CODE(S): NEC 705.12(B)(3)

CAUTION: MULTIPLE SOURCES OF POWER



POWER TO THIS BUILDING IS ALSO SUPPLIED FROM THE FOLLOWING SOURCES WITH DISCONNECTS LOCATED AS SHOWN

PHOTOVOLTAIC ARRAY ON THE ROOF

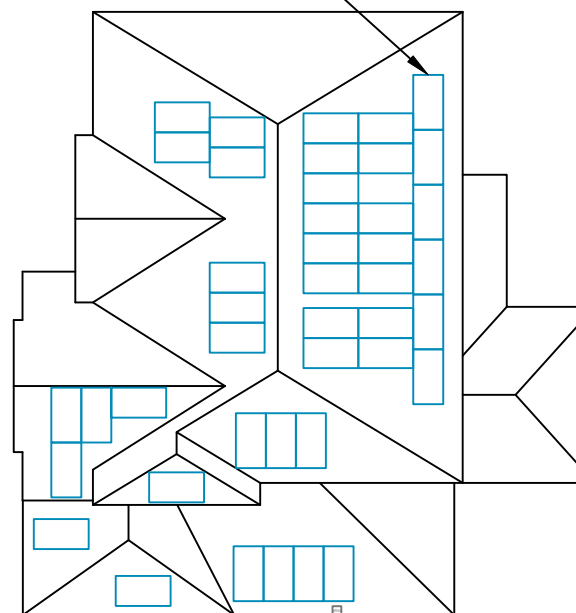

- (N) AC DISCONNECT (EXTERIOR)
- (E) UTILITY METER (EXTERIOR)
- (E) MAIN SERVICE PANEL (INTERIOR)
- (E) SMART ENERGY BOX (EXTERIOR)
- (E) LG ESS HOME 8 BATTERY (EXTERIOR)
- (E) BACKUP LOAD PANEL (EXTERIOR)
- (N) ENPHASE IQ COMBINER 4 (EXTERIOR)



257 SOUTHEAST COYLE DRIVE, LEE'S SUMMIT, MO 64063

SYSTEM UTILIZES MICROINVERTERS LOCATED UNDER EACH SOLAR MODULE

NOTES

1. PLACARDS SHALL MEET THE REQUIREMENTS OF ARTICLES 690 AND 705, UNLESS OTHERWISE SPECIFIED PER LOCAL AHJ REQUIREMENTS.
2. PLACARDS SHALL MEET THE REQUIREMENTS OF SECTION 110.21(B) AS REQUIRED AND SHALL COMPLY WITH ANSI Z535.4-2011, PRODUCT SAFETY SIGNS AND LABELS.
3. PLACARDS SHALL BE PERMANENTLY AFFIXED TO THE EQUIPMENT OR WIRING METHOD.
4. PLACARDS SHALL BE OF SUFFICIENT DURABILITY TO WITHSTAND THE ENVIRONMENT INVOLVED AND SHALL BE HANDWRITTEN.
5. PLACARDS SHALL NOT COVER EXISTING MANUFACTURER LABELS.

LABEL LOCATION

SERVICE PANEL
PER CODE: NEC 705.10



CUSTOMER INFORMATION

NAME: JEFFREY BRANDHORST

ADDRESS: 257 SOUTHEAST COYLE DRIVE, LEE'S SUMMIT, MO 64063

38.911451, -94.306996
APN: 6024017130000000

AHJ: MO-CITY OF LEE'S SUMMIT

UTILITY: KCPL-M

PRN NUMBER: RGS-88302



WARNING PLACARDS

DRAFTED BY: B.PATIL
QC'ED BY: D.XAVIER

PAPER SIZE: 17"X11"

SCALE: AS NOTED

REV: E

DATE: 12/1/2023

PL-01

ROOF ACCESS POINT

ROOF ACCESS POINT



CUSTOMER INFORMATION

NAME:JEFFREY BRANDHORST

ADDRESS:257 SOUTHEAST COYLE DRIVE,
LEE'S SUMMIT, MO 64063

38.911451, -94.306996
APN: 60240171300000000

AHJ:MO-CITY OF LEE'S SUMMIT

UTILITY:KCPL-M

PRN NUMBER:RGS-88302



ROOF ACCESS POINT

DRAFTED BY: B.PATIL	PAPER SIZE:17"X11"
QC'ED BY:D.XAVIER	

SCALE:AS NOTED	REV:E
----------------	-------

DATE:12/1/2023	PL-02
----------------	-------

SPEC SHEET

SOLAR'S MOST TRUSTED



REC N-PEAK 3 BLACK SERIES

PREMIUM FULL BLACK MONO N-TYPE SOLAR PANELS



- MONO N-TYPE: THE MOST EFFICIENT C-SI TECHNOLOGY
- NO LIGHT INDUCED DEGRADATION
- SUPER-STRONG FRAME UP TO 7000 PA SNOW LOAD
- FLEXIBLE INSTALLATION OPTIONS
- FEATURING REC'S PIONEERING TWIN DESIGN
- BIFACIAL CELLS CAN PRODUCE ENERGY FROM BOTH SIDES

400 WP POWER



REC N-PEAK 3 BLACK SERIES PRODUCT SPECIFICATIONS

GENERAL DATA	
Cell type:	132 half-cut mono c-Si n-type cells 6 strings of 22 cells in series
Glass:	0.13 in solar glass with anti-reflective surface treatment in accordance with EN12150
Backsheet:	Highly resistant polymer (black)
Frame:	Anodized aluminum (black) with silver support bars
Junction box:	3-part, 3 bypass diodes, lead-free IP68 rated, in accordance with IEC 62790
Connectors:	Stäubli MC4 PV-KBT4/KST4 (12 AWG) in accordance with IEC 62852, IP68 only when connected
Cable:	12 AWG PV wire, 47.2 ± 47.2 in in accordance with EN 50618
Dimensions:	74.8 x 40.9 x 1.2 in (19.7 sq-ft)
Weight:	48.0 lbs
Origin:	Made in Singapore

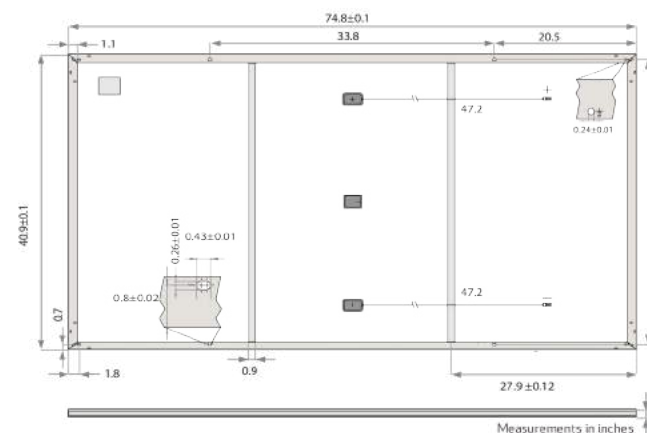

ELECTRICAL DATA		Product Code: RECxxxNP3 Black	
Power Output - P _{MAX} (Wp)	390	400	
Watt Class Sorting - (W)	0/+10	0/+10	
Nominal Power Voltage - V _{MPP} (V)	36.8	37.6	
Nominal Power Current - I _{MPP} (A)	10.60	10.64	
Open Circuit Voltage - V _{OC} (V)	44.8	45.0	
Short Circuit Current - I _{SC} (A)	11.31	11.39	
Panel Efficiency (%)	19.5	20.3	
Power Output - P _{MAX} (Wp)	295	302	
Nominal Power Voltage - V _{MPP} (V)	34.4	35.2	
Nominal Power Current - I _{MPP} (A)	8.56	8.59	
Open Circuit Voltage - V _{OC} (V)	41.9	42.1	
Short Circuit Current - I _{SC} (A)	9.13	9.20	

STC
NMOT

Values at standard test conditions (STC: air mass AM1.5, irradiance 1000 W/m², temperature 25°C), based on a production spread with a tolerance of P_{MAX}, V_{OC} & I_{SC} ±3% within one watt class. Nominal module operating temperature (NMOT: air mass AM1.5, irradiance 800W/m², temperature 20°C, windspeed 1 m/s). *Where xxx indicates the nominal power class (P_{MAX}) at STC above.

MAXIMUM RATINGS	
Operational temperature:	-40 ... +185°F
Maximum system voltage:	1000 V
Maximum test load (front):	+7000 Pa (146 lbs/sq-ft)*
Maximum test load (rear):	-4000 Pa (83.5 lbs/sq-ft)*
Max series fuse rating:	25 A
Max reverse current:	25 A

*See installation manual for mounting instructions. Design load = Test load / 1.5 (safety factor)

WARRANTY			
	Standard	REC ProTrust	
Installed by an REC Certified Solar Professional	No	Yes	Yes
System Size	All	<25 kW	25-500 kW
Product Warranty (yrs)	20	25	25
Power Warranty (yrs)	25	25	25
Labor Warranty (yrs)	0	25	10
Power in Year 1	98%	98%	98%
Annual Degradation	0.25%	0.25%	0.25%
Power in Year 25	92%	92%	92%

The REC ProTrust Warranty is only available on panels purchased through an REC Certified Solar Professional installer. Warranty conditions apply. See www.recgroup.com for more details.

CERTIFICATIONS	
IEC 61215-2:2016, IEC 61730-2:2016, UL 61730	
IEC 62804	PID
IEC 61701	Salt Mist
IEC 62716	Ammonia Resistance
UL 61730	Fire Type Class 2
UL 790	Fire Class Type C
IEC 62782	Dynamic Mechanical Load
IEC 61215-2:2016	Hailstone (1.37 m)
ISO 14001, ISO 9001, IEC 45001, IEC 62941	

TEMPERATURE RATINGS*	
Nominal Module Operating Temperature:	44.3°C (±2°C)
Temperature coefficient of P _{MAX} :	-0.34 %/°C
Temperature coefficient of V _{OC} :	-0.26 %/°C
Temperature coefficient of I _{SC} :	0.04 %/°C

DELIVERY INFORMATION	
Panels per pallet:	33
Panels per 40 ft GP/high cube container:	792 (24 pallets)
Panels per 53 ft truck:	TBD

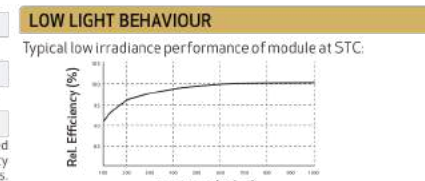

Available from:

Founded in 1996, REC Group is an international pioneering solar energy company dedicated to empowering consumers with clean, affordable solar power. As Solar's Most Trusted, REC is committed to high quality, innovation, and a low carbon footprint in the solar materials and solar panels it manufactures. Headquartered in Norway with operational headquarters in Singapore, REC also has regional hubs in North America, Europe, and Asia-Pacific.

REC Solar PTE. LTD.
20 Tuas South Ave. 14
Singapore 637312
post@recgroup.com



Ref: Rev. 1.1 - 11.22 Specifications subject to change without notice.



CUSTOMER INFORMATION

NAME: JEFFREY BRANDHORST

ADDRESS: 257 SOUTHEAST COYLE DRIVE, LEE'S SUMMIT, MO 64063

38.911451, -94.306996
APN: 6024017130000000

AHJ: MO-CITY OF LEE'S SUMMIT

UTILITY: KCPL-M

PRN NUMBER: RGS-88302



MODULE SPEC SHEET

DRAFTED BY: B.PATIL
QC'ED BY: D.XAVIER

PAPER SIZE: 17"X11"

SCALE: AS NOTED

REV: E

DATE: 12/1/2023

SS-01

SPEC SHEET



DATA SHEET



IQ8M and IQ8A Microinverters

Our newest IQ8 Microinverters are the industry's first microgrid-forming, software defined microinverters with split-phase power conversion capability to convert DC power to AC power efficiently. The brain of the semiconductor-based microinverter is our proprietary application specific integrated circuit (ASIC) which enables the microinverter to operate in grid-tied or off-grid modes. This chip is built in advanced 55nm technology with high speed digital logic and has superfast response times to changing loads and grid events, alleviating constraints on battery sizing for home energy systems.



Part of the Enphase Energy System, IQ8 Series Microinverters integrate with the IQ Battery, IQ Gateway, and the Enphase App monitoring and analysis software.



IQ8 Series Microinverters redefine reliability standards with more than one million cumulative hours of power-on testing, enabling an industry-leading limited warranty of up to 25 years.



Connect PV modules quickly and easily to IQ8 Series Microinverters using the included Q-DCC-2 adapter cable with plug-n-play MC4 connectors.



IQ8 Series Microinverters are UL listed as PV Rapid Shutdown Equipment and conform with various regulations, when installed according to manufacturer's instructions.

Easy to install

- Lightweight and compact with plug-n-play connectors
- Power Line Communication (PLC) between components
- Faster installation with simple two-wire cabling

High productivity and reliability

- Produce power even when the grid is down*
- More than one million cumulative hours of testing
- Class II double-insulated enclosure
- Optimized for the latest high-powered PV modules

Microgrid-forming

- Complies with the latest advanced grid support**
- Remote automatic updates for the latest grid requirements
- Configurable to support a wide range of grid profiles
- Meets CA Rule 21 (UL 1741-SA) and IEEE 1547:2018 (UL 1741-SB 3rd Ed.)

Note:

IQ8 Microinverters cannot be mixed together with previous generations of Enphase microinverters (IQ7 Series, IQ6 Series, etc.) in the same system.

IQ8M and IQ8A Microinverters

INPUT DATA (DC)		IQ8M-72-2-US	IQ8A-72-2-US
Commonly used module pairings ¹	W	260 - 460	295 - 500
Module compatibility		54-cell / 108 half-cell, 60-cell / 120 half-cell, 66-cell / 132 half-cell and 72-cell / 144 half-cell	
MPPT voltage range	V	30 - 45	32 - 45
Operating range	V	16 - 58	
Min. / Max. start voltage	V	22 / 58	
Max. input DC voltage	V	60	
Max. continuous input DC current	A	12	
Max. input DC short-circuit current	A	25	
Max. module I _{sc}	A	20	
Overtoltage class DC port		II	
DC port backfeed current	mA	0	
PV array configuration		1 x 1 Ungrounded array; No additional DC side protection required; AC side protection requires max 20A per branch circuit	
OUTPUT DATA (AC)		IQ8M-72-2-US	IQ8A-72-2-US
Peak output power	VA	330	366
Max. continuous output power	VA	325	349
Nominal (L-L) voltage / range ²	V	240 / 211 - 264	
Max. continuous output current	A	1.35	1.45
Nominal frequency	Hz	60	
Extended frequency range	Hz	47 - 68	
AC short circuit fault current over 3 cycles	Arms	2	
Max. units per 20 A (L-L) branch circuit ³		11	
Total harmonic distortion		<5%	
Overtoltage class AC port		III	
AC port backfeed current	mA	30	
Power factor setting		1.0	
Grid-tied power factor (adjustable)		0.85 leading - 0.85 lagging	
Peak efficiency	%	97.8	97.7
CEC weighted efficiency	%	97.5	97
Night-time power consumption	mW	60	
MECHANICAL DATA			
Ambient temperature range		-40°C to +60°C (-40°F to +140°F)	
Relative humidity range		4% to 100% (condensing)	
DC Connector type		MC4	
Dimensions (H x W x D)		212 mm (8.3") x 175 mm (6.9") x 30.2 mm (1.2")	
Weight		1.08 kg (2.38 lbs)	
Cooling		Natural convection - no fans	
Approved for wet locations		Yes	
Pollution degree		PD3	
Enclosure		Class II double-insulated, corrosion resistant polymeric enclosure	
Environ. category / UV exposure rating		NEMA Type 6 / outdoor	
COMPLIANCE			
Certifications		CA Rule 21 (UL 1741-SA), UL 62109-1, IEEE 1547:2018 (UL 1741-SB 3 rd Ed.), FCC Part 15 Class B, ICES-0003 Class B, CAN / CSA-C22.2 NO. 107.1-01 This product is UL Listed as PV Rapid Shutdown Equipment and conforms with NEC 2014, NEC 2017, and NEC 2020 section 690.12 and C22.1-2018 Rule 64-218 Rapid Shutdown of PV Systems, for AC and DC conductors, when installed according to manufacturer's instructions.	

(1) Pairing PV modules with wattage above the limit may result in additional clipping losses. See the compatibility calculator at <https://link.enphase.com/module-compatibility>. (2) Nominal voltage range can be extended beyond nominal if required by the utility. (3) Limits may vary. Refer to local requirements to define the number of microinverters per branch in your area.

IQ8MA-12A-DS-0069-03-EN-US-2022-12-27



CUSTOMER INFORMATION

NAME: JEFFREY BRANDHORST

ADDRESS: 257 SOUTHEAST COYLE DRIVE, LEE'S SUMMIT, MO 64063

38.911451, -94.306996
APN: 6024017130000000

AHJ: MO-CITY OF LEE'S SUMMIT

UTILITY: KCPL-M

PRN NUMBER: RGS-88302



INVERTER SPEC SHEET

DRAFTED BY: B.PATIL
QC'ED BY: D.XAVIER
PAPER SIZE: 17"X11"

SCALE: AS NOTED
REV: E

DATE: 12/1/2023
SS-02

SPEC SHEET

Data Sheet
Enphase Networking

Enphase IQ Combiner 4/4C

X-IQ-AM1-240-4
X-IQ-AM1-240-4C



X-IQ-AM1-240-4C

X-IQ-AM1-240-4

The **Enphase IQ Combiner 4/4C** with Enphase IQ Gateway and integrated LTE-M1 cell modem (included only with IQ Combiner 4C) consolidates interconnection equipment into a single enclosure and streamlines IQ microinverters and storage installations by providing a consistent, pre-wired solution for residential applications. It offers up to four 2-pole input circuits and Eaton BR series busbar assembly.

Smart

- Includes IQ Gateway for communication and control
- Includes Enphase Mobile Connect cellular modem (CELLMODEM-M1-06-SP-05), included only with IQ Combiner 4C
- Includes solar shield to match Enphase IQ Battery aesthetics and deflect heat
- Flexible networking supports Wi-Fi, Ethernet, or cellular
- Optional AC receptacle available for PLC bridge
- Provides production metering and consumption monitoring

Simple

- Centered mounting brackets support single stud mounting
- Supports bottom, back and side conduit entry
- Up to four 2-pole branch circuits for 240 VAC plug-in breakers (not included)
- 80A total PV or storage branch circuits

Reliable

- Durable NRTL-certified NEMA type 3R enclosure
- Five-year limited warranty
- Two years labor reimbursement program coverage included for both the IQ Combiner SKU's
- UL listed

Enphase IQ Combiner 4/4C

MODEL NUMBER

IQ Combiner 4 (X-IQ-AM1-240-4)	IQ Combiner 4 with Enphase IQ Gateway printed circuit board for integrated revenue grade PV production metering (ANSI C12.20 +/- 0.5%) and consumption monitoring (+/- 2.5%). Includes a silver solar shield to match the IQ Battery system and IQ System Controller 2 and to deflect heat.
IQ Combiner 4C (X-IQ-AM1-240-4C)	IQ Combiner 4C with Enphase IQ Gateway printed circuit board for integrated revenue grade PV production metering (ANSI C12.20 +/- 0.5%) and consumption monitoring (+/- 2.5%). Includes Enphase Mobile Connect cellular modem (CELLMODEM-M1-06-SP-05), a plug-and-play industrial-grade cell modem for systems up to 60 microinverters. (Available in the US, Canada, Mexico, Puerto Rico, and the US Virgin Islands, where there is adequate cellular service in the installation area.) Includes a silver solar shield to match the IQ Battery and IQ System Controller and to deflect heat.

ACCESSORIES AND REPLACEMENT PARTS

Ensemble Communications Kit COMMS-CELLMODEM-M1-06 CELLMODEM-M1-06-SP-05 CELLMODEM-M1-06-AT-05	- Includes COMMS-KIT-01 and CELLMODEM-M1-06-SP-05 with 5-year Sprint data plan for Ensemble sites - 4G based LTE-M1 cellular modem with 5-year Sprint data plan - 4G based LTE-M1 cellular modem with 5-year AT&T data plan
Circuit Breakers BRK-10A-2-240V BRK-15A-2-240V BRK-20A-2P-240V BRK-15A-2P-240V-B BRK-20A-2P-240V-B	Supports Eaton BR210, BR215, BR220, BR230, BR240, BR250, and BR260 circuit breakers. Circuit breaker, 2 pole, 10A, Eaton BR210 Circuit breaker, 2 pole, 15A, Eaton BR215 Circuit breaker, 2 pole, 20A, Eaton BR220 Circuit breaker, 2 pole, 15A, Eaton BR215B with hold down kit support Circuit breaker, 2 pole, 20A, Eaton BR220B with hold down kit support
EPLC-01	Power line carrier (communication bridge pair), quantity - one pair
XA-SOLARSHIELD-ES	Replacement solar shield for IQ Combiner 4/4C
XA-PLUG-120-3	Accessory receptacle for Power Line Carrier in IQ Combiner 4/4C (required for EPLC-01)
XA-ENV-PCBA-3	Replacement IQ Gateway printed circuit board (PCB) for Combiner 4/4C
X-IQ-NA-HD-125A	Hold down kit for Eaton circuit breaker with screws.

ELECTRICAL SPECIFICATIONS

Rating	Continuous duty
System voltage	120/240 VAC, 60 Hz
Eaton BR series busbar rating	125 A
Max. continuous current rating	65 A
Max. continuous current rating (input from PV/storage)	64 A
Max. fuse/circuit rating (output)	90 A
Branch circuits (solar and/or storage)	Up to four 2-pole Eaton BR series Distributed Generation (DG) breakers only (not included)
Max. total branch circuit breaker rating (input)	80A of distributed generation / 95A with IQ Gateway breaker included
Production metering CT	200 A solid core pre-installed and wired to IQ Gateway
Consumption monitoring CT (CT-200-SPLIT)	A pair of 200 A split core current transformers

MECHANICAL DATA

Dimensions (WxHxD)	37.5 x 49.5 x 16.8 cm (14.75" x 19.5" x 6.63"). Height is 21.06" (53.5 cm) with mounting brackets.
Weight	7.5 kg (16.5 lbs)
Ambient temperature range	-40° C to +46° C (-40° to 115° F)
Cooling	Natural convection, plus heat shield
Enclosure environmental rating	Outdoor, NRTL-certified, NEMA type 3R, polycarbonate construction
Wire sizes	- 20 A to 50 A breaker inputs: 14 to 4 AWG copper conductors - 60 A breaker branch input: 4 to 1/0 AWG copper conductors - Main lug combined output: 10 to 2/0 AWG copper conductors - Neutral and ground: 14 to 1/0 copper conductors Always follow local code requirements for conductor sizing.
Altitude	To 2000 meters (6,560 feet)

INTERNET CONNECTION OPTIONS

Integrated Wi-Fi	802.11b/g/n
Cellular	CELLMODEM-M1-06-SP-05, CELLMODEM-M1-06-AT-05 (4G based LTE-M1 cellular modem). Note that an Enphase Mobile Connect cellular modem is required for all Ensemble installations.
Ethernet	Optional, 802.3, Cat5E (or Cat 5) UTP Ethernet cable (not included)

COMPLIANCE

Compliance, IQ Combiner	UL 1741, CAN/CSA C22.2 No. 107.1, 47 CFR, Part 15, Class B, ICES 003 Production metering: ANSI C12.20 accuracy class 0.5 (PV production) Consumption metering: accuracy class 2.5
Compliance, IQ Gateway	UL 60601-1/CANCSA 22.2 No. 61010-1

To learn more about Enphase offerings, visit enphase.com

© 2021 Enphase Energy. All rights reserved. Enphase, the Enphase logo, IQ Combiner 4/4C, and other names are trademarks of Enphase Energy, Inc. Data subject to change. 10-21-2021



CUSTOMER INFORMATION

NAME: JEFFREY BRANDHORST

ADDRESS: 257 SOUTHEAST COYLE DRIVE,
LEE'S SUMMIT, MO 64063

38.911451, -94.306996
APN: 6024017130000000

AHJ: MO-CITY OF LEE'S SUMMIT

UTILITY: KCPL-M

PRN NUMBER: RGS-88302



COMBINER SPEC SHEET

DRAFTED BY: B.PATIL
QC'ED BY: D.XAVIER
PAPER SIZE: 17"X11"

SCALE: AS NOTED
REV: E

DATE: 12/1/2023
SS-03



To learn more about Enphase offerings, visit enphase.com





The Respect Your Roof Deserves

When integrating with a home, solar attachments must be dependable for the lifetime of the rooftop. Due to recent innovations, many asphalt shingles have bonded courses. A mount that protects without the need to pry shingles can really speed things up.

Halo UltraGrip™ (HUG™) is here to respect the roof. Its Halo is a cast-aluminum barrier that encases the UltraGrip, our industrial-grade, foam-and-mastic seal. This allows HUG to accelerate the installation process and provide the utmost in waterproofing protection. Give your roof a HUG.™



UltraGrip™ Seal Technology
HUG UltraGrip utilizes a state-of-the-art seal design that uses a unique, foam-and-mastic combination. The foam-backed adhesive provides an entirely new flashing system that conforms and adheres to every nook and cranny of composition shingles, filling gaps and shingle step-downs (up to 1/8" in height).

Multi-Tiered Waterproofing
HUG utilizes a multi-tiered stack of components to provide revolutionary waterproofing protection. The Halo cast-aluminum, raised-perimeter foundation surrounds the UltraGrip base—a foam-backed mastic seal combination that prevents water intrusion by adhering and sealing with the shingle surface.

Halo UltraGrip™ is part of the QuickMount® product line.



Rafter & Deck Mounting Options
Mount HUG to the roof rafters, the roof deck, or both with our custom-engineered RD (rafter-or-deck) Structural Screw. The RD Structural Screw anchors HUG to the roof with an EPDM sealing washer, completing the stack of waterproofing barriers. See backside for more installation information.

Triple Rated & Certified to Respect the Roof™
UL 2703, 441 (27)
TAS 100(A)-95

Tech Brief

Adaptive, Rafter-Friendly Installation



Hit the rafter? Good to go!
When you find a rafter, you can move on. Only 2 RD Structural Screws are needed.



Miss the rafter? Try it again.
Place another screw to the left or right. If rafter is found, install 3rd and final screw.



Still no luck? Install the rest.
If more than 3 screws miss the rafter, secure six screws to deck mount it.

Tech Brief

Trusted Strength & Less Hassle



25-Year Warranty
Product guaranteed free of impairing defects.

Structural capacities of HUG™ were reviewed in many load directions, with racking rail running cross-slope or up-slope in relation to roof pitch.

For further details, see the HUG certification letters for attaching to rafters and decking.

IronRidge designed the HUG, in combination with the RD Structural Screw to streamline installs, which means the following:

- No prying shingles
- No roof nail interference
- No pilot holes necessary
- No sealant (in most cases)
- No butyl shims needed

Attachment Loading

The rafter-mounted HUG has been tested and rated to support 1004 (lbs) of uplift and 368 (lbs) of lateral load.

Structural Design

Parts are designed and certified for compliance with the International Building Code & ASCE/SEI-7.

Water Seal Ratings

HUG passed both the UL 441 Section 27 "Rain Test" and TAS 100(A)-95 "Wind Driven Rain Test" by Intertek.

UL 2703 System

Systems conform to UL 2703 mechanical and bonding requirements. See Flush Mount Manual for more info.



CUSTOMER INFORMATION

NAME: JEFFREY BRANDHORST

ADDRESS: 257 SOUTHEAST COYLE DRIVE, LEE'S SUMMIT, MO 64063

38.911451, -94.306996
APN: 6024017130000000

AHJ: MO-CITY OF LEE'S SUMMIT

UTILITY: KCPL-M

PRN NUMBER: RGS-88302



MOUNT SPEC SHEET

DRAFTED BY: B.PATIL
QC'ED BY: D.XAVIER

PAPER SIZE: 17"X11"

SCALE: AS NOTED

REV: E

DATE: 12/1/2023

SS-04



XR Rail Family

Tech Brief

Solar Is Not Always Sunny

Over their lifetime, solar panels experience countless extreme weather events. Not just the worst storms in years, but the worst storms in 40 years. High winds capable of ripping panels from a roof, and snowfalls weighing enough to buckle a panel frame.

XR Rails are the structural backbone preventing these results. They resist uplift, protect against buckling and safely and efficiently transfer loads into the building structure. Their superior spanning capability requires fewer roof attachments, reducing the number of roof penetrations and the amount of installation time.

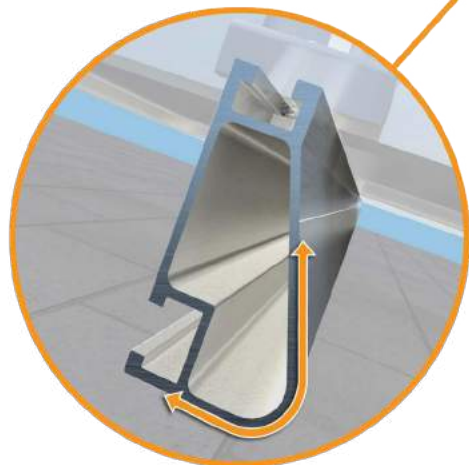
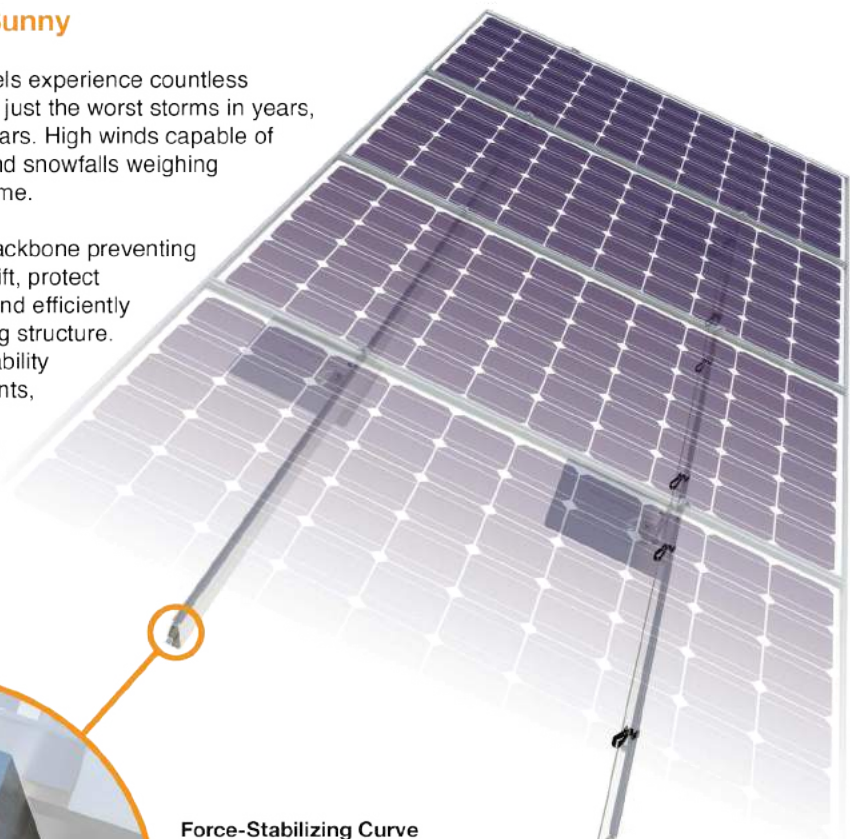

Force-Stabilizing Curve

Sloped roofs generate both vertical and lateral forces on mounting rails which can cause them to bend and twist. The curved shape of XR Rails is specially designed to increase strength in both directions while resisting the twisting. This unique feature ensures greater security during extreme weather and a longer system lifetime.

Compatible with Flat & Pitched Roofs

XR Rails are compatible with FlashFoot and other pitched roof attachments.

IronRidge offers a range of tilt leg options for flat roof mounting applications.

Corrosion-Resistant Materials

All XR Rails are made of marine-grade aluminum alloy, then protected with an anodized finish. Anodizing prevents surface and structural corrosion, while also providing a more attractive appearance.



XR Rail Family

The XR Rail Family offers the strength of a curved rail in three targeted sizes. Each size supports specific design loads, while minimizing material costs. Depending on your location, there is an XR Rail to match.

Tech Brief



XR10

XR10 is a sleek, low-profile mounting rail, designed for regions with light or no snow. It achieves 6 foot spans, while remaining light and economical.

- 6' spanning capability
- Moderate load capability
- Clear anodized finish
- Internal splices available



XR100

XR100 is the ultimate residential mounting rail. It supports a range of wind and snow conditions, while also maximizing spans up to 8 feet.

- 8' spanning capability
- Heavy load capability
- Clear & black anodized finish
- Internal splices available



XR1000

XR1000 is a heavyweight among solar mounting rails. It's built to handle extreme climates and spans 12 feet or more for commercial applications.

- 12' spanning capability
- Extreme load capability
- Clear anodized finish
- Internal splices available

Rail Selection

The following table was prepared in compliance with applicable engineering codes and standards. Values are based on the following criteria: ASCE 7-10, Roof Zone 1, Exposure B, Roof Slope of 7 to 27 degrees and Mean Building Height of 30 ft. Visit IronRidge.com for detailed span tables and certifications.

Load		Rail Span					
Snow (PSF)	Wind (MPH)	4'	5' 4"	6'	8'	10'	12'
None	100	XR10		XR100		XR1000	
	120						
	140						
10-20	160						
	100						
	120						
30	140						
	160						
	100						
40	160						
	100						
50-70	160						
80-90	160						



CUSTOMER INFORMATION

NAME: JEFFREY BRANDHORST

ADDRESS: 257 SOUTHEAST COYLE DRIVE, LEE'S SUMMIT, MO 64063

38.911451, -94.306996
APN: 6024017130000000

AHJ: MO-CITY OF LEE'S SUMMIT

UTILITY: KCPL-M

PRN NUMBER: RGS-88302



RAIL SPEC SHEET

DRAFTED BY: B.PATIL
QC'ED BY: D.XAVIER

PAPER SIZE: 17"X11"

SCALE: AS NOTED

REV: E

DATE: 12/1/2023

SS-05

SPEC SHEET



INFORMATION SHEET

KUP-L-Tap, Insul-Eater Single Use Insulation Piercing Connectors

1) Specifications:

Conductors - Class B or C Aluminum and or Copper wires
 Temperature rating - 90°C

Item ID	Run	Tap	Torque (in-lbs)	Tools (Socket & Box wrenches)	Voltage
IPC-1/0-2	1/0 - 8 AWG	#2 - #8 AWG	192	1/2"	300 (480 grounded Y system)
IPC-4/0-6	4/0 - #4 AWG	#6 - #14 AWG	156	1/2"	600
IPC-4/0-2/0 * +	4/0 - #2 AWG	2/0 - #6 AWG	300	1/2"	600
IPC-250-4/0 * #	250 kcmil-#1 AWG	4/0 - #6 AWG	360	5/8"	600
IPC-350-4/0	350 kcmil-4/0	4/0 - #10 AWG	300	5/8"	300 (480 grounded Y system)
IPC-350-350	350 kcmil-4/0	350 kcmil-4/0	300	5/8"	300 (480 grounded Y system)
IPC-500-12	500-250 kcmil	#10-#12 AWG	300	5/8"	300 (480 grounded Y system)
IPC-500-250	500-250 kcmil	250 - #4 AWG	720	5/8" & 1 1/16"	600
IPC-500-500 *	500-300 kcmil	500-250 kcmil	900	7/8"	600
IPC-750-500 *	750-500kcmil	500-350kcmil	900	7/8"	600

* Can be used on bare wire or bare & insulated wire combinations
 * - When used on bare conductor, break out the tabs and extend wire 1.5 - 2" beyond the connector body.
 + Tap side is limited to .528" OD including the insulation.
 # Max OD on the main is .730" including insulation

-IPC-250-4/0 & IPC-4/0-2/0- To insure the top and bottom are aligned -There are lines on the side of the connector to help.

2) Installation Instructions For Use as a Run and Tap:

- a) Remove the tab blocking the **Main** conductor groove with screwdriver or **pliers**.
 - Tap must be broken cleanly to the bottom of the channel.
- b) Cut insulated cable end **squarely** and apply a crisscrossed layer of UL listed electrical **tape over the exposed end of the wire**.
 Tape the exposed wire end with Two pieces of **tape** measuring approximately three inches long.
- c) **Separate** the connector halves by loosening the bolt.
- d) Slide the connector over the run conductor.
- e) Insert the **tap** conductor until it **butts** up against the **tab**.
BE SURE THE TAP CONDUCTOR IS ALL THE WAY THROUGH THE CONNECTOR.
- f) Center both conductors over the piercing teeth, and finger tighten the bolt.
-(Refer to the diagram below for correct placement of conductors)
- g) Holding the connector firmly in your hand, tighten the bolt to the **torque** in the above table.



3) Additional Information

- a) Connector can be used on **BUILDING CODE (Stranded CLASS B or C)** wire either copper and/or aluminum conductors
- b) The Insul-Eater is **fully** insulated without an external cover or tape
- c) The Insul-Eater connector should not be installed when **tap conductor is under load**

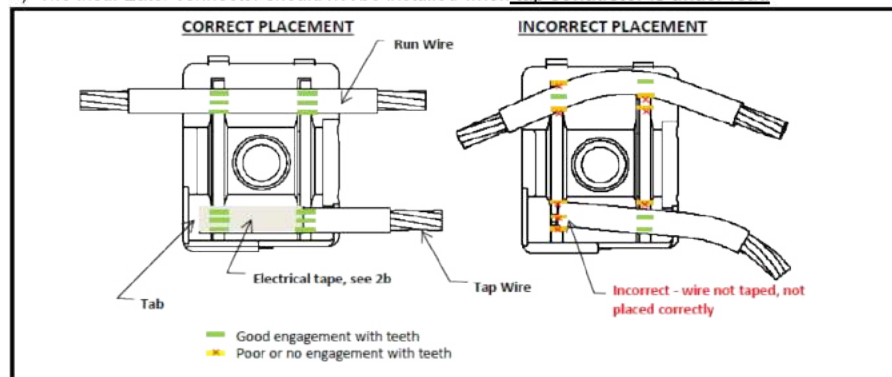

Form 73
 Revised 6-15-2016



CUSTOMER INFORMATION

NAME: JEFFREY BRANDHORST

ADDRESS: 257 SOUTHEAST COYLE DRIVE,
 LEE'S SUMMIT, MO 64063

38.911451, -94.306996
 APN: 6024017130000000

AHJ: MO-CITY OF LEE'S SUMMIT

UTILITY: KCPL-M

PRN NUMBER: RGS-88302



TAP CONNECTOR SPEC SHEET

DRAFTED BY: B.PATIL QC'ED BY: D.XAVIER	PAPER SIZE: 17"X11"
SCALE: AS NOTED	REV: E
DATE: 12/1/2023	SS-06



Solar, Sleeker Than Ever

Most solar installations use mounting rails and fasteners to secure modules to the building structure, but these critical components often protrude from the sides of the modules, giving arrays a coarse look.

CAMO is an invisible fastener that secures solar modules flush to rail ends, creating a clean, sleek appearance. CAMO works with nearly all solar modules and installs without tools or torque specifications. It simply rotates into place to structurally secure and electrically bond with the module.

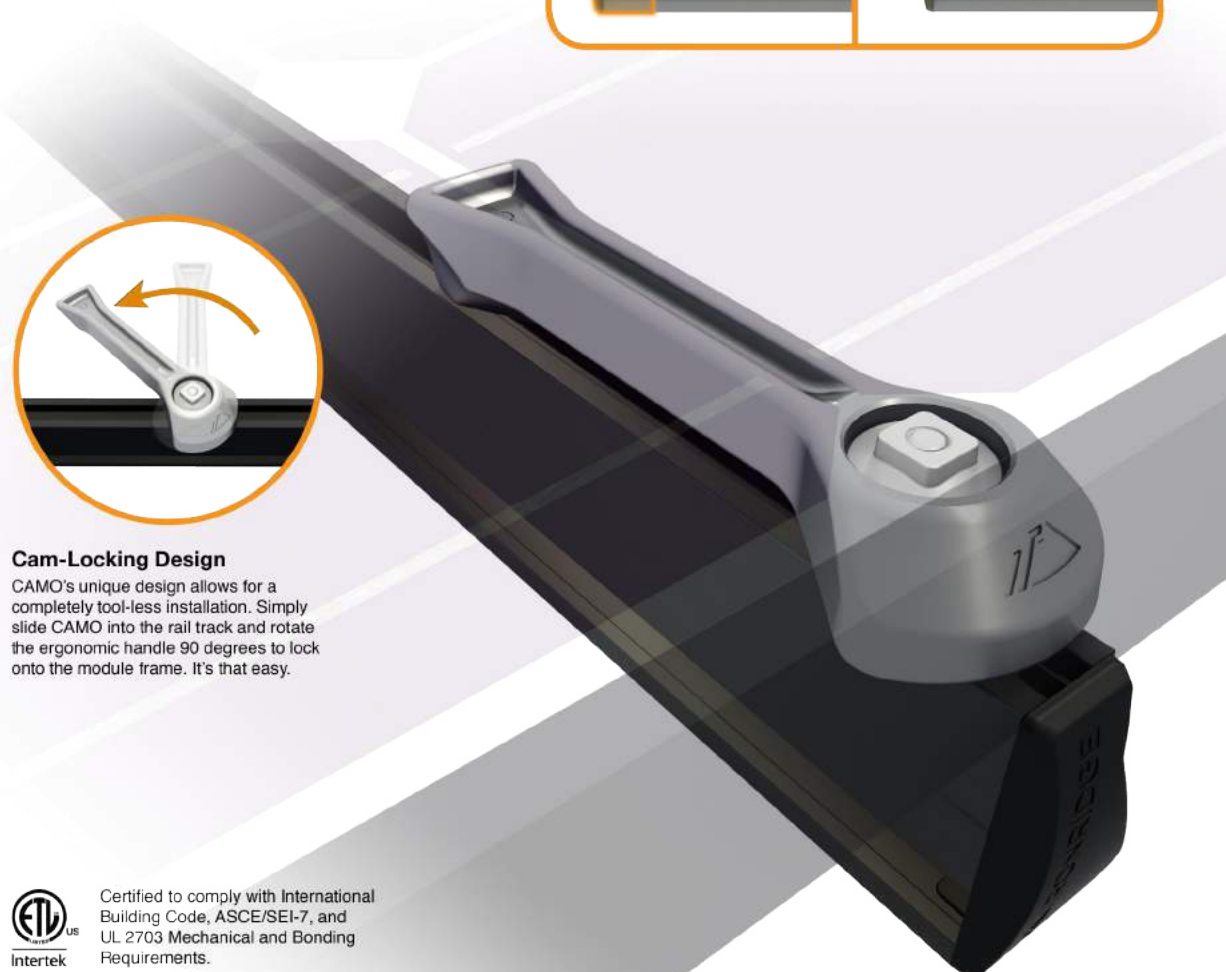

Cam-Locking Design

CAMO's unique design allows for a completely tool-less installation. Simply slide CAMO into the rail track and rotate the ergonomic handle 90 degrees to lock onto the module frame. It's that easy.

 Certified to comply with International Building Code, ASCE/SEI-7, and UL 2703 Mechanical and Bonding Requirements.

Tech Brief

Hidden End Cam

Easy, Tool-Less Installation

A. PLACE CAMO

Slide CAMO into rail track far enough to clear the module frame. CAMO requires 6" of clearance from end of rail.

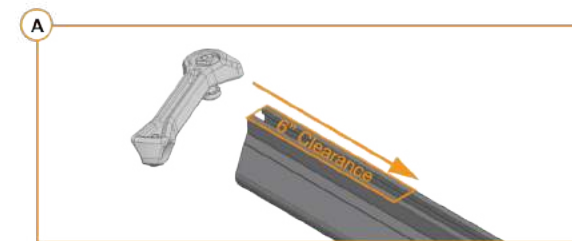

B. PLACE MODULE

Place module on rails and align flush with rail ends (module cells not shown in image to provide clarity). The module can overhang the rail no more than 1/4".



C. SLIDE CAMO

Pull CAMO towards rail end, at a 45 degree angle, so linear bonding pin contacts the module flange edge.

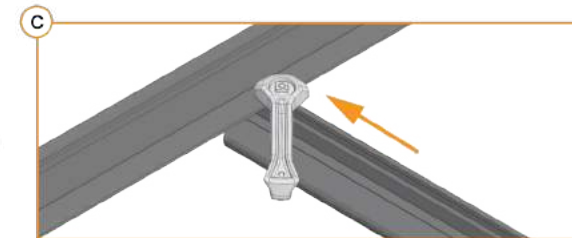

D. SECURE CAMO

Rotate handle with an upwards motion until CAMO snaps into rail track. Ensure CAMO bonding pins are fully seated on top of module frame.



Tech Brief

Tested & Certified

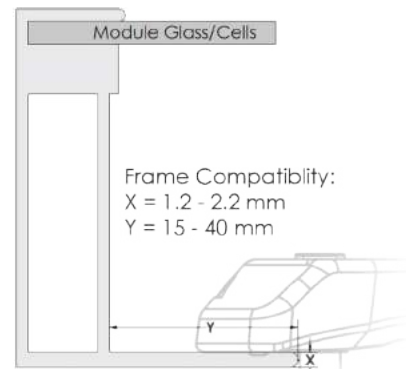

UL 2703

CAMO conforms to STD UL 2703 (2015) requirements and fits modules with bottom flanges that meet specifications shown in the frame compatibility diagram on the left.

See IronRidge Installation Manuals for full ratings and a list of certified compatible modules.



CUSTOMER INFORMATION

NAME: JEFFREY BRANDHORST

ADDRESS: 257 SOUTHEAST COYLE DRIVE, LEE'S SUMMIT, MO 64063

38.911451, -94.306996
APN: 60240171300000000

AHJ: MO-CITY OF LEE'S SUMMIT

UTILITY: KCPL-M

PRN NUMBER: RGS-88302



CAMO SPEC SHEET

DRAFTED BY: B.PATIL
QC'ED BY: D.XAVIER
PAPER SIZE: 17"X11"

SCALE: AS NOTED
REV: E

DATE: 12/1/2023
SS-07



UFO Family of Components

Tech Brief

Simplified Grounding for Every Application

The UFO family of components eliminates the need for separate grounding hardware by bonding solar modules directly to IronRidge XR Rails. All system types that feature the UFO family—Flush Mount, Tilt Mount and Ground Mount—are fully listed to the UL 2703 standard.

UFO hardware forms secure electrical bonds with both the module and the rail, resulting in many parallel grounding paths throughout the system. This leads to safer and more reliable installations.



Stopper Sleeve

The Stopper Sleeve snaps onto the UFO, converting it into a bonded end clamp.

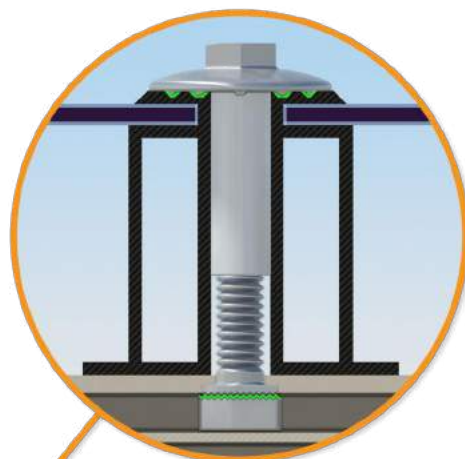

Universal Fastening Object (UFO)

The UFO securely bonds solar modules to XR Rails. It comes assembled and lubricated, and can fit a wide range of module heights.

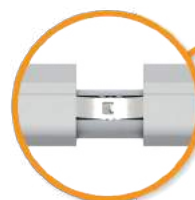

BOSS™ Splice

Bonded Structural Splice connects rails with built-in bonding teeth. No tools or hardware needed.

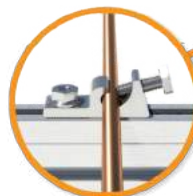

Grounding Lug

A single Grounding Lug connects an entire row of PV modules to the grounding conductor.



Bonded Attachments

The bonding bolt attaches and bonds the L-foot to the rail. It is installed with the same socket as the rest of the system.

System Diagram

Tech Brief

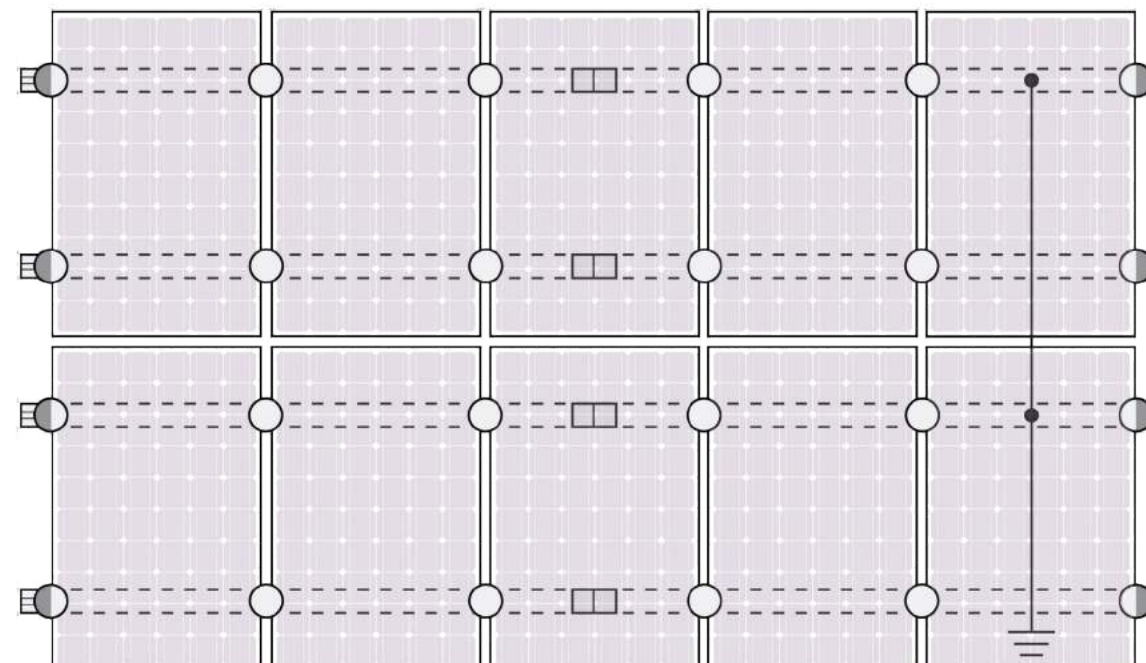

○ UFO ◐ Stopper Sleeve ● Grounding Lug ◻ BOSS™ Splice ≡ Ground Wire

⚠ Approved Enphase microinverters can provide equipment grounding of IronRidge systems, eliminating the need for grounding lugs and field installed equipment ground conductors (EGC). A minimum of two microinverters mounted to the same rail and connected to the same Engage cable is required. Refer to installation manuals for additional details.

UL Certification

The IronRidge Flush Mount, Tilt Mount, and Ground Mount Systems have been listed to UL 2703 by Intertek Group plc.

UL 2703 is the standard for evaluating solar mounting systems. It ensures these devices will maintain strong electrical and mechanical connections over an extended period of time in extreme outdoor environments.

Go to IronRidge.com/UFO

Cross-System Compatibility

Feature	Flush Mount	Tilt Mount	Ground Mount
XR Rails	✓	✓	XR100 & XR1000
UFO/Stopper	✓	✓	✓
BOSS™ Splice	✓	✓	N/A
Grounding Lugs	1 per Row	1 per Row	1 per Array
Microinverters & Power Optimizers	Compatible with most MLPE manufacturers. Refer to system installation manual.		
Fire Rating	Class A	Class A	N/A
Modules	Tested or Evaluated with over 400 Framed Modules Refer to installation manuals for a detailed list.		



CUSTOMER INFORMATION

NAME: JEFFREY BRANDHORST

ADDRESS: 257 SOUTHEAST COYLE DRIVE, LEE'S SUMMIT, MO 64063

38.911451, -94.306996
APN: 60240171300000000

AHJ: MO-CITY OF LEE'S SUMMIT

UTILITY: KCPL-M

PRN NUMBER: RGS-88302



UL CERTIFICATION SPEC SHEET

DRAFTED BY: B.PATIL
QC'ED BY: D.XAVIER

PAPER SIZE: 17"X11"

SCALE: AS NOTED

REV: E

DATE: 12/1/2023

SS-08