



construction managers

general contractors

design builders

SUBMITTAL REVIEW

Date: August 17, 2017

Submittal # 008 PRIVATE SANITARY STRUCTURES
33-3000-02-A

Subcontractor: Kat Excavation
Bart Fisher

Project#: 417 The Residence at Echelon

Submit To: NSPJ Architects
Tim Hauschild
Clint Evans

SUBMITTAL FOR APPROVAL	
Job Name/No: <u>417 Residences of Echelon</u>	
<input checked="" type="checkbox"/> REVIEWED	<input type="checkbox"/> REVISE & RESUBMIT
<input type="checkbox"/> REVIEWED& NOTED	<input type="checkbox"/> REJECTED
Submittal received for general compliance with the Contract Documents. Contractor's review does not relieve sub/vendor of responsibility for dimension, quantities, accuracy or completion of submittals or from any responsibilities required by terms and conditions of Subcontract/PO with Luke Draily Construction Co., Inc. Sub/Vendors shall follow all manufacturer installation instructions. Installing contractor shall be responsible to coordinate with trades for hookup, supports, routing, etc.	
By: <u>J. Wilcox</u>	Date: <u>8-17-17</u>

Engineering Solutions	Shop Drawing Review
Project: <u>Echelon</u>	Date: <u>8/24/17</u>
Submittal #: <u>Sanitary 3</u>	By: <u>MJS</u>
<input type="checkbox"/> APPROVED	<input type="checkbox"/> REJECTED
<input checked="" type="checkbox"/> APPROVED AS NOTED	

* A-4 ADDED

Job Name: THE RESIDENCE @ ECHELON SAN
 Job #: 17-1300
 Customer: KAT EXCAVATION INC 1038
 Structure ID: A-3
 Type: 4' DIA MANHOLES W/ 8" BASE

Rim: 1005.84'
 Invert: 1002.49'
 Rim to Invert: 3.35'
 Precast Height: 3.00'
 Overall Height: 4.35'

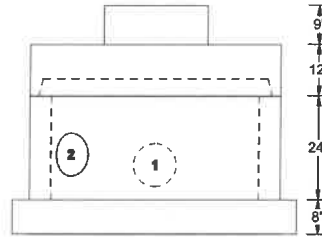
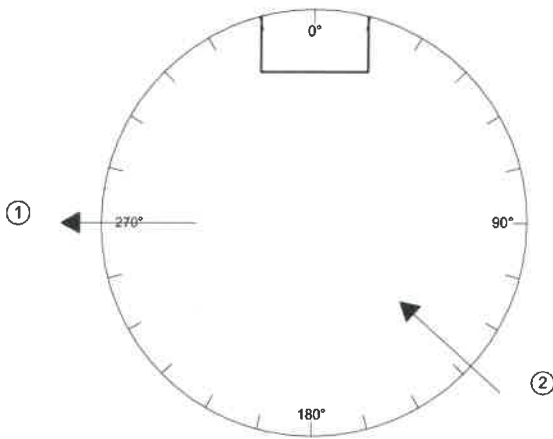

33-3000-02-a



Barbour Concrete Company
 816.796.3344

08/15/2017

Pipe#	Elevation	Pipe	Hole Type	UptoCenter	OverInside	Hole_Height	Hole_Width	Description	UOM	Quantity	Weight
(1)	1002.49	8 PVC	AL0285	8	113	9.75	9.75	1502 MUDRING ONLY 00150215	EA	1	302
(2)	1002.69	8 PVC	AL0285	10.25	55.25	9.75	9.75	MANHOLE FLAT LID 4'DIA X 12"H WITH TG TOP JOINT	EA	1	1,700
								DEV BASE MH 4'DIA X 32"H W/GASKET CAST IN	EA	1	4,000
								00150223 1502 COVER ONLY	EA	1	161
								285 - A-LOK GASKET 8" PVC	EA	2	
								DAMPPROOFING - ASPHALT	GAL	0.29	
Total Structure											6,163

MH REINFORCING IN ACCORDANCE WITH ASTM C-478
 BASE REINFORCING
 4' DIA MH = #4 @ 12" OCEW
 5, 6, 7, 8, AND 10 FT DIA = #5 @ 6 OCEW
 WALL THICKNESS = (ID DIA / 12) + 1
 AIR ENTRAINED CONCRETE = 4000 PSI IN 28 DAYS

Job Name: THE RESIDENCE @ ECHELON SAN
 Job #: 17-1300
 Customer: KAT EXCAVATION INC 1038
 Structure ID: A-4
 Type: 4' DIA MANHOLES W/ 8" BASE

Rim: 1006.14'
 Invert: 1003.14'
 Rim to Invert: 3.00'
 Precast Height: 2.67'
 Overall Height: 4.00'

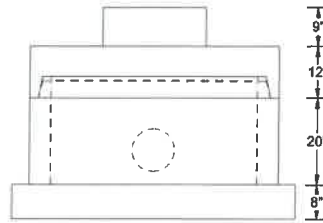
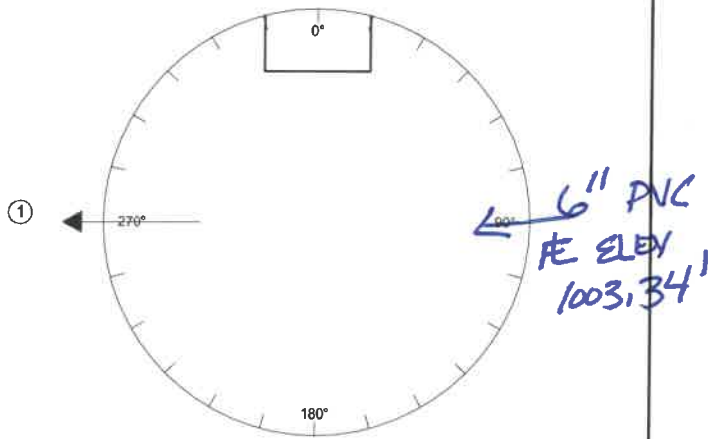

NOTE
 CONTRACTOR TO FIELD LOCATE
 AND CORE INFLOW PIPE OR
 PROVIDE BARBOUR CONCRETE WITH
 INFORMATION TO INCLUDE IN
 PRODUCTION OF MANHOLE



Barbour Concrete Company
 816.796.3344

08/15/2017

Pipe#	Elevation	Pipe	Hole Type	UptoCenter	OverInside	Hole_Height	Hole_Width	Description	UOM	Quantity	Weight
(1)	1003.14	8 PVC	AL0285	8	113	9.75	9.75	1502 MUDRING ONLY 00150215	EA	1	302
								MANHOLE FLAT LID 4'DIA X 12"H WITH TG TOP JOINT	EA	1	1,700
								DEV BASE MH 4'DIA X 28"H W/GASKET CAST IN	EA	1	3,746
								00150223 1502 COVER ONLY	EA	1	161
								285 - A-LOK GASKET 8" PVC	EA	1	
								DAMP-PROOFING - ASPHALT	GAL	0.27	
								Total Structure			5,909

MH REINFORCING IN ACCORDANCE WITH ASTM C-478
 BASE REINFORCING
 4' DIA MH = #4 @ 12" OCEW
 5, 6, 7, 8, AND 10 FT DIA = #5 @ 6 OCEW
 WALL THICKNESS = (ID DIA / 12) + 1
 AIR ENTRAINED CONCRETE = 4000 PSI IN 28 DAYS

Job Name: THE RESIDENCE @ ECHELON SAN
 Job #: 17-1300
 Customer: KAT EXCAVATION INC 1038
 Structure ID: B-1
 Type: 4' DIA MANHOLES W/ 8" BASE

Rim: 1021.05'
 Invert: 1008'
 Rim to Invert: 13.05'
 Precast Height: 12.50'
 Overall Height: 14.05'

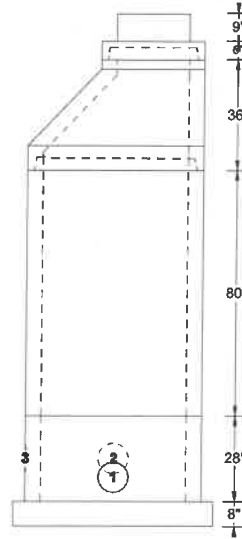
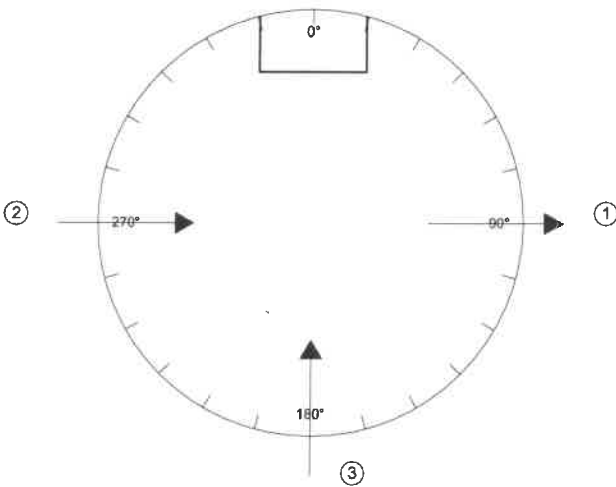

Barbour Concrete Company
 816.796.3344

08/15/2017

Pipe#	Elevation	Pipe	Hole Type	UptoCenter	OverInside	Hole_Height	Hole_Width	Description	UOM	Quantity	Weight
(1)	1008	8 PVC	AL0285	8	37.75	9.75	9.75	1502 MUDRING ONLY 00150215	EA	1	302
(2)	1008.5	8 PVC	AL0285	14	113	9.75	9.75	ADJUSTMENT RING 24"ID X 6"H WITH TG JOINT	EA	1	210
(3)	1008.5	8 PVC	AL0285	14	75.5	9.75	9.75	MANHOLE CONE ECCENTRIC 4"ID X 36" WITH TG TOP JOINT	EA	1	2,025
								MANHOLE RISER 4"ID X 80"H	EA	1	5,713
								DEV BASE MH 4"DIA X 36"H W/GASKET CAST IN	EA	1	4,254
								00150223 1502 COVER ONLY	EA	1	161
								285 - A-LOK GASKET 8" PVC	EA	3	
								DAMPPOOFING - ASPHALT	GAL	0.742	
Total Structure											12,665

MH REINFORCING IN ACCORDANCE WITH ASTM C-478
 BASE REINFORCING
 4' DIA MH = #4 @ 12" OCEW
 5, 6, 7, 8, AND 10 FT DIA = #5 @ 6 OCEW
 WALL THICKNESS = (ID DIA / 12) + 1
 AIR ENTRAINED CONCRETE = 4000 PSI IN 28 DAYS

Job Name: THE RESIDENCE @ ECHELON SAN
 Job #: 17-1300
 Customer: KAT EXCAVATION INC 1038
 Structure ID: B-2
 Type: 4' DIA MANHOLES W/ 8" BASE

Rim: 1021.6'
 Invert: 1010.13'
 Rim to Invert: 11.47'
 Precast Height: 10.99'
 Overall Height: 12.47'

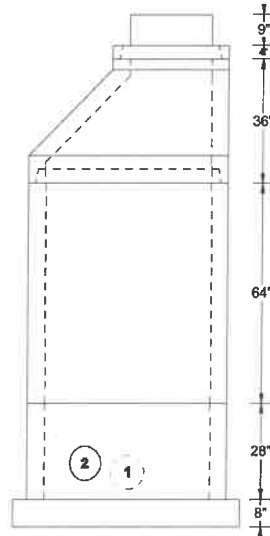
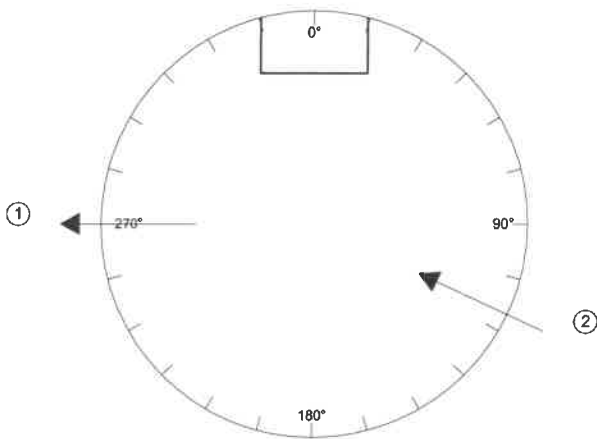

Barbour Concrete Company
 816.796.3344

08/15/2017

Pipe#	Elevation	Pipe	Hole Type	UptoCenter	OverInside	Hole_Height	Hole_Width	Description	UOM	Quantity	Weight
(1)	1010.13	8 PVC	AL0285	8	113	9.75	9.75	1502 MUDRING ONLY 00150215	EA	1	302
(2)	1010.33	8 PVC	AL0285	10.25	48.25	9.75	9.75	ADJUSTMENT RING 24" X 4"H WITH TG JOINT	EA	1	140
								MANHOLE CONE ECCENTRIC 4'DIA X 36" WITH TG TOP JOINT	EA	1	2,025
								MANHOLE RISER 4'DIA X 64"H	EA	1	4,571
								DEV BASE MH 4'DIA X 36"H W/GASKET CAST IN	EA	1	4,286
								00150223 1502 COVER ONLY	EA	1	161
								285 - A-LOK GASKET 8" PVC	EA	2	
								DAMPPROOFING - ASPHALT	GAL	0.692	
								Total Structure			11,485

MH REINFORCING IN ACCORDANCE WITH ASTM C-478
 BASE REINFORCING
 4' DIA MH = #4 @ 12" OCEW
 5, 6, 7, 8, AND 10 FT DIA = #5 @ 6 OCEW
 WALL THICKNESS = (ID DIA / 12) + 1
 AIR ENTRAINED CONCRETE = 4000 PSI IN 28 DAYS

Job Name: THE RESIDENCE @ ECHELON SAN
 Job #: 17-1300
 Customer: KAT EXCAVATION INC 1038
 Structure ID: B-3
 Type: 4' DIA MANHOLES W/ 8" BASE

Rim: 1024.1'
 Invert: 1012.3'
 Rim to Invert: 11.80'
 Precast Height: 11.33'
 Overall Height: 12.80'

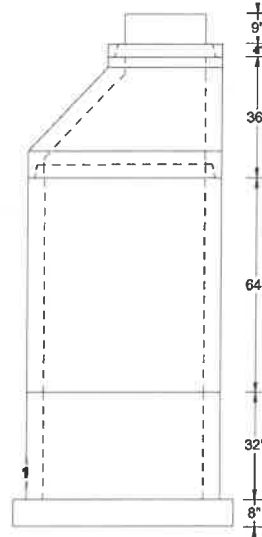
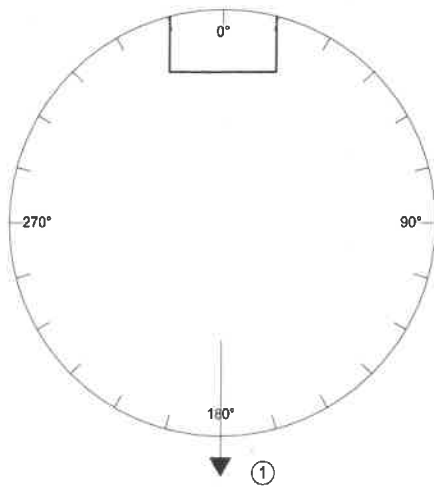

Barbour Concrete Company
 816.796.3344

08/15/2017

Pipe#	Elevation	Pipe	Hole Type	UptoCenter	OverInside	Hole_Height	Hole_Width	Description	UOM	Quantity	Weight
(1)	1012.3	8 PVC	AL0285	8	75.5	9.75	9.75	1502 MUDRING ONLY 00150215	EA	1	302
								ADJUSTMENT RING 24" X 4"H WITH TG JOINT	EA	1	140
								MANHOLE CONE ECCENTRIC 4'ID X 36" WITH TG TOP JOINT	EA	1	2,025
								MANHOLE RISER 4'ID X 64"H	EA	1	4,571
								DEV BASE MH 4'DIA X 40"H W/1 STEP AND GASKET CAST IN	EA	1	4,603
								00150223 1502 COVER ONLY	EA	1	161
								285 - A-LOK GASKET 8" PVC	EA	1	
								DAMPPROOFING - ASPHALT	GAL	0.702	
Total Structure											11,802

MH REINFORCING IN ACCORDANCE WITH ASTM C-478
 BASE REINFORCING
 4' DIA MH = #4 @ 12" OCEW
 5, 6, 7, 8, AND 10 FT DIA = #5 @ 6 OCEW
 WALL THICKNESS = (ID DIA / 12) + 1
 AIR ENTRAINED CONCRETE = 4000 PSI IN 28 DAYS

Job Name: THE RESIDENCE @ ECHELON SAN
 Job #: 17-1300
 Customer: KAT EXCAVATION INC 1038
 Structure ID: C-1
 Type: 4' DIA MANHOLES W/ 8" BASE

Rim: 1021.05'
 Invert: 1008.75'
 Rim to Invert: 12.30'
 Precast Height: 11.83'
 Overall Height: 13.30'

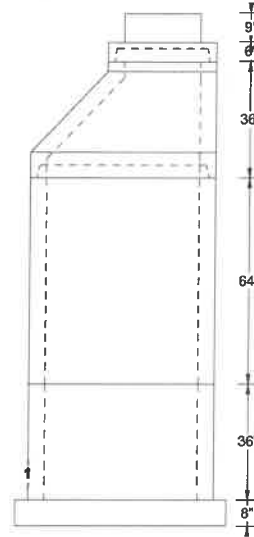
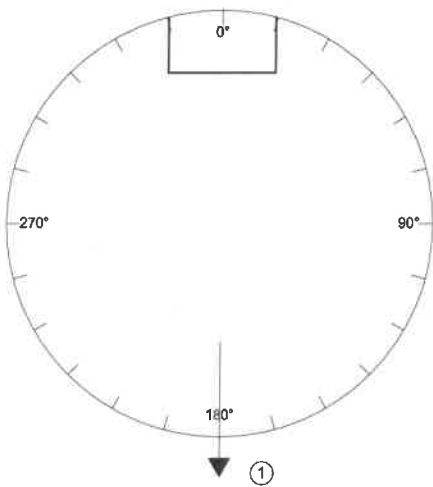

Barbour Concrete Company
 816.796.3344

08/15/2017

Pipe#	Elevation	Pipe	Hole Type	UptoCenter	OverInside	Hole_Height	Hole_Width	Description	UOM	Quantity	Weight
(1)	1008.75	8 PVC	AL0285	8	75.5	9.75	9.75	1502 MUDRING ONLY 00150215	EA	1	302
								ADJUSTMENT RING 24"ID X 6"H WITH TG JOINT	EA	1	210
								MANHOLE CONE ECCENTRIC 4'ID X 36" WITH TG TOP JOINT	EA	1	2,025
								MANHOLE RISER 4'ID X 64"H	EA	1	4,571
								DEV BASE MH 4'DIA X 44"H W/1 STEP AND GASKET CAST IN	EA	1	4,889
								00150223 1502 COVER ONLY	EA	1	161
								285 - A-LOK GASKET 8" PVC	EA	1	
								DAMP PROOFING - ASPHALT	GAL	0.722	
								Total Structure			12,158

MH REINFORCING IN ACCORDANCE WITH ASTM C-478
 BASE REINFORCING
 4' DIA MH = #4 @ 12" OCEW
 5, 6, 7, 8, AND 10 FT DIA = #5 @ 6 OCEW
 WALL THICKNESS = (ID DIA / 12) + 1
 AIR ENTRAINED CONCRETE = 4000 PSI IN 28 DAYS

1502A MANHOLE COVER

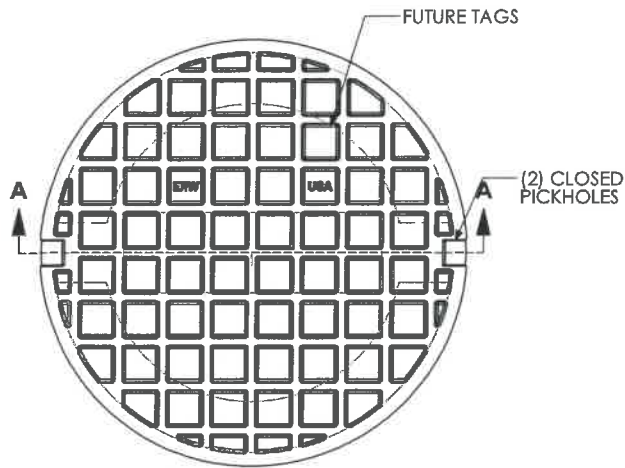

BOTTOM VIEW

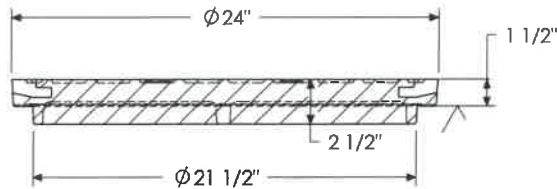

SECTION A-A

PRODUCT NUMBER

00150223

DESIGN FEATURES

MATERIALS
COVER-GRAY IRON
ASTM A48 CL35B

DESIGN LOAD
HEAVY DUTY

COATING
UNDIPPED

OPEN AREA
N/A

✓ DESIGNATES MACHINE SURFACE

161 LBS

DRAWING DETAILS

ORIGINAL DRAWING: DEW 9/30/2009
REVISED BY: DEW 11/20/2009

Corporate Headquarters
301 Spring Street
PO Box 459
East Jordan, MI
49727-0439
800.874.4100



Call Today for More Information

800.626.4653

EJIW EAST JORDAN
IRON WORKS EST. 1883
WE COVER YOUR INFRASTRUCTURE™

www.ejiw.com
MADE IN THE USA

*Weights (lbs./kg.) dimensions (inches/mm., and drawings provided for your guidance.
*We reserve the right to modify specifications without prior notice.
*Uncontrolled distribution.

CONFIDENTIAL: This drawing is the property of East Jordan Iron works, Inc., and embodies confidential information, registered marks, trade secret information, and/or know how that is the property of East Jordan Iron Works, Inc. ©Copyright 2009 East Jordan Iron Works, Inc.

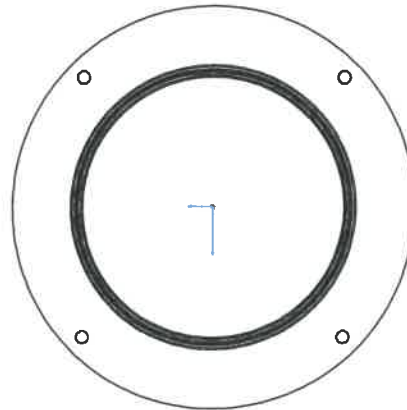
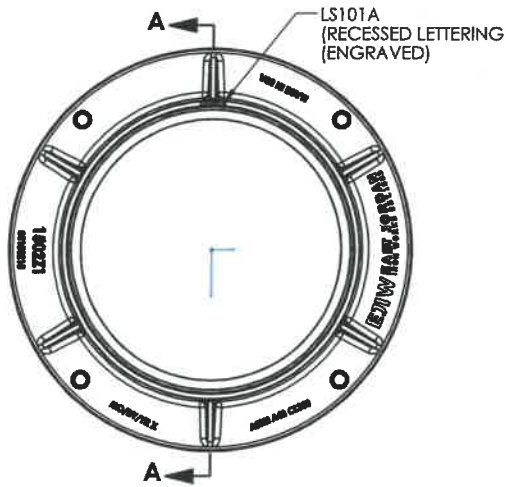

BOTTOM VIEW

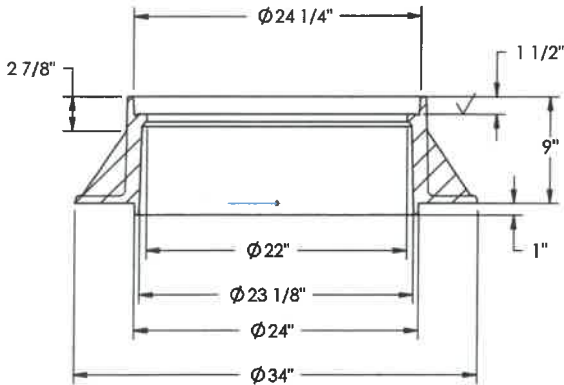

SECTION A-A

CONFIDENTIAL: This drawing is the property of East Jordan Iron Works, Inc. and embodies confidential information, trade secret information, and/or know how that is the property of East Jordan Iron Works, Inc. © Copyright 2008 East Jordan Iron Works, Inc.

EJIW EAST JORDAN
IRON WORKS EST. 1883

800-626-4653
www.ejiw.com

MADE IN USA

PRODUCT NUMBER

00150215

CATALOG NUMBER

1502Z1

FRAME

LOAD RATING
HEAVY DUTY

COATING
UNDIPPED

SPECIFICATION

FRAME - GRAY IRON
ASTM A48 CL35B

302 LBS.

OPEN AREA
N/A

√ DESIGNATES
MACHINED SURFACE

DRAWN

DATE

DEW

10/15/08

LAST REVISED

DATE

DEW

01/09/09

ML-13-NCR

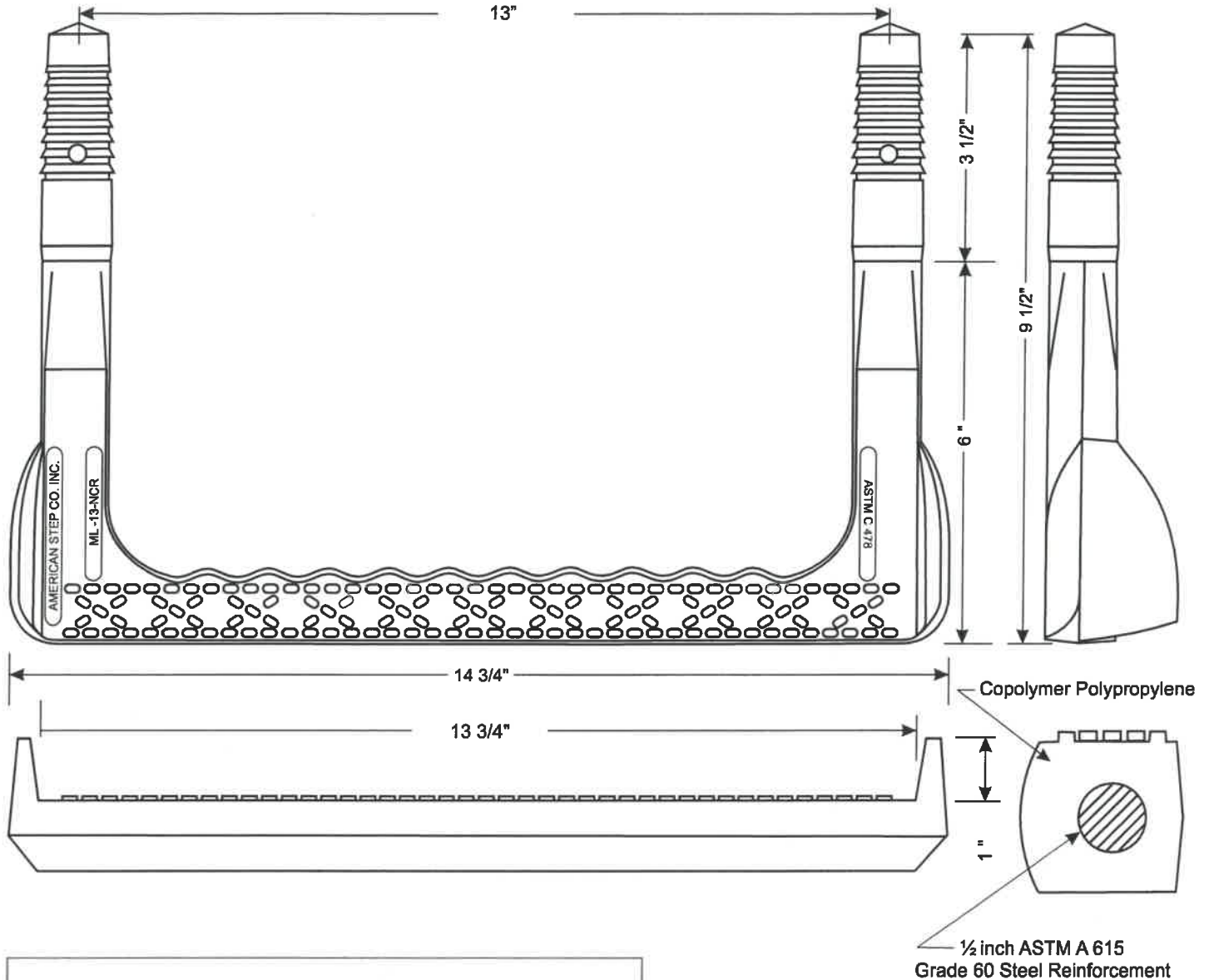

ML-13-NCR

Mechanical Lock Installation Methods
Minimum Concrete Strength Must Be 3000 psi.

Preformed Holes

Two preformed holes on 13" centers
Holes must be parallel
Diameter of holes are 1.1" tapering to 7/8" in 3 1/2" of depth

Drilled Holes

Drill two 1" holes on 13" centers with a minimum depth of 3 3/4"
Use 1" masonry bit for drilling.
Holes must be parallel.

Drive step with sledge hammer until both legs are completely seated

This step meets or exceeds ASTM C 478 and OSHA Standards when properly installed.



American Step Company, Inc.

P.O. Box 137
830 East Broadway
Griffin, GA 30224-0137

800-988-STEP
770-467-9844 (OFFICE)
770-467-8011 (FAX)



The Company With Connections®



INCOMPARABLE PIPE-TO-MANHOLE CONNECTORS FOR SANITARY SYSTEMS

X-CEL

● A-LOK X-CEL

Designed to produce a guaranteed watertight seal between pipe and concrete, the **A-LOK X-CEL** flexible pipe-to-manhole connector provides maximum performance on the job site. Its unique design not only saves valuable project time, but also ensures longevity and offers unsurpassed environmental benefits.

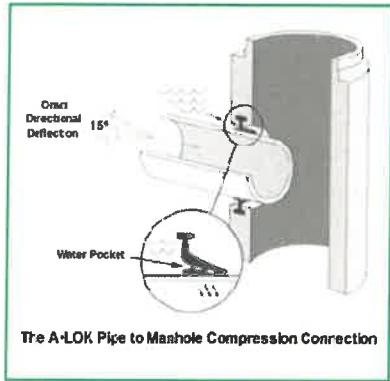

A-LOK X-CEL connectors prevent infiltration and ex-filtration into wastewater or stormwater systems, and are installed in the precast structure in a way that does not require coring or placement after the base component is cast. This eliminates residual waste from coring, disposal of the slugs or wasted raw material utilization or energy. Once cast-in, the connector becomes an integral component of the structure wall.

Based on the traditional **A-LOK** connector, the **X-CEL's** enhanced features improve performance. Take the patented "water pocket" for example, which utilizes the untapped pressure of ground water to exert a clamping force around the connector and pipe, allowing the connector to perform in deeper installations.

Demonstrated in tests higher than 15 psi of hydrostatic water pressure, the **X-CEL's** unique design provides 45 percent more rubber contact with the pipe, allowing for greater pipe deflection.

● MATERIAL

Molded or extruded from compounds formulated for wastewater applications and engineered to conform to the requirements of section 4.1.1 of ASTM C-923, the standard rubber connector is available in alternative compounds upon request. Contact an **A-LOK** representative regarding special applications, such as the presence of hydrocarbons.

● KEY ADVANTAGES

The **A-LOK X-CEL** offers distinct advantages for engineers, specifiers, precasters and municipalities. An enhanced profile gives the connector 45% greater rubber contact with the pipe, thus allowing the pipe to be deflected in excess of 10 degrees of omnidirectional deflection, all the while maintaining a watertight seal. These enhancements allow for more flexibility to compensate for pipe shear due to settlement or ground movement.

● KEY ADVANTAGES (continued)

On larger-diameter pipe, where size prohibits a gasket from being installed in a flat plane, the **X-CEL** can be configured for casting in a curve with the connector staying perpendicular to the center line of the pipe. Discovered through years of extensive research and development, the configurations cause no loss of compression or deflection.

Functioning on pure compression, the **X-CEL** allows for fast and easy field installation. After the connector and pipe are cleaned and lubricated, the pipe is simply centered in the connector and inserted. Backfilling can be done immediately, thus enhancing project safety and overcoming the typical problems of water, running sand and other unstable trench conditions.

For Specifiers, the **X-CEL** connector offers a guaranteed solution to the age-old containment system problem of the best way to connect pipes and concrete structures. Precasters using **X-CEL** connectors experience increased satisfaction due to their ability to offer a complete watertight, guaranteed product, while municipalities that install **X-CEL** will ultimately spend less on road repair by avoiding the possibility of pot/sink holes that are often the result of leaking, non-connected, systems.

● PRODUCT REFERENCES

A.) ASTM C-923

Resilient Connector Between Reinforced Concrete Manholes Structures, Pipe and Laterals.

B.) ASTM C-1244

Standard Test Method For Concrete Sewer Manholes by the Negative Air Pressure (Vacuum) Test

C.) ASTM C-478

Standard Specification for Precast Reinforced Concrete Manhole Sections

● PERFORMANCE STANDARD

The **A-LOK X-CEL** guaranteed Connector meets or exceeds all material and test requirements outlined in ASTM C-923: "Resilient Connectors Between Reinforced Concrete Manhole Structures, Pipes and Laterals."

Molded or extruded from compounds formulated for wastewater applications, the standard rubber connector is engineered to conform with the requirements of section 4.1.1 of ASTM C-923. Alternative compounds are available upon special request.

PERFORMANCE STANDARD (continued)

RESILIENT TEST REQUIREMENTS OF A.S.T.M. C-923

TEST	RESULTS	ASTM METHOD
Chemical resistance 1 N Sulfuric acid 1 N Hydrochloric Acid	no weight loss no weight loss	at 22°C for 48h
Tensile strength	1200 psi or 8.5 MPa, min	D 412
Elongation at break	350% min.	
Hardness	±5 from mfg's. specified hardness	D 2240 (Shore A durometer)
Accelerated oven-aging	decr. of 15%, max. of original tensile strength, decr. of 20% max. of elongation	D 573, 70±1°C for 7 days
Compression set	decr. of 25%, max. of original deflection	D 395, Method B, at 70°C for 22h
Water absorption	increase of 10%, max. of original by weight	D 471, immerse 0.75 by 2-in. or 19 by 25-mm Specimen in distilled water at 70°C for 48h
Ozone resistance	rating 0	D 1171
Low-temp brittle point	no fracture at -40°C	D 746
Tear resistance	200 lb/in. or 34 kn/m	D 624, Method B

Copyright ASTM INTERNATIONAL. Reprinted with permission

DIMENSIONAL DATA

A•LOK X-CEL Cross Sections / Pipe Size OD's

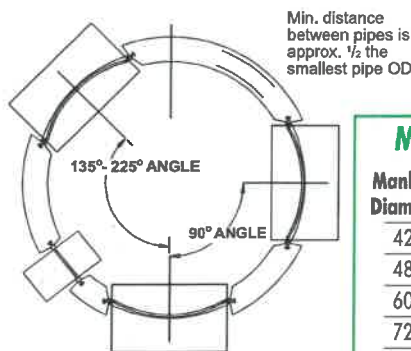
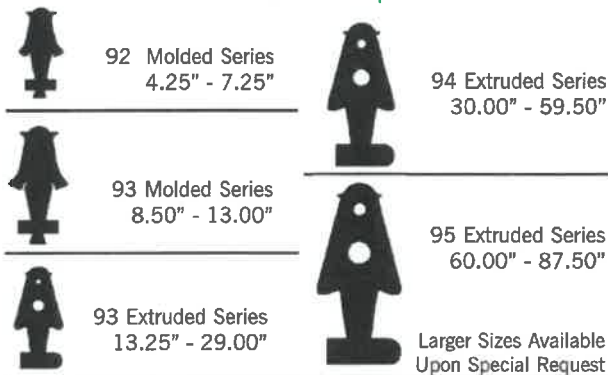

MAX. PIPE SIZE OD's

MAX. PIPE SIZE OD's

Manhole Diameter	135° - 225° Pipe Angle	90° Pipe Angle
42"	26.5"	22.0"
48"	31.5"	25.0"
60"	42.0"	32.0"
72"	52.5"	38.0"
84"	59.5"	44.0"
96"	73.5"	50.0"
108"	76.0"	56.0"
120"	85.0"	62.0"

PRODUCT SPECIFICATIONS

A flexible pipe to manhole connector shall be used whenever a pipe penetrates into a precast concrete manhole or structure. The connector shall be the **A•LOK X-CEL CONNECTOR** as manufactured by **A•LOK PRODUCTS, INC.**, Tullytown, PA, or approved equal.

The design of the connector shall provide a flexible, watertight seal between the pipe and concrete structure. The connector shall assure that a seal is made between:

(1) The connector and the structure wall by casting the connector integrally with the structure wall during the manufacturing process in a manner that it will not pull out during pipe coupling. The connector shall also be capable of being cast into a round structure by curving the connector in a manner that allows it to remain centrally located within the structure wall and perpendicular to the pipe. This configuration will result in no loss of seal or deflection of pipe entering a concrete structure.

(2) The seal between the connector and the pipe shall be made by the compression of the connector between the outside circumference of the pipe and the interior hole opening of the structure. The connector shall be the only component to affect the seal between the pipe and structure.

The connector shall be made from materials that conform to the physical and chemical requirements outlined in Section 4, "Materials and Manufacture" of ASTM C-923 Standard Specification for Resilient Connectors between Reinforced Concrete Manhole Structures, Pipes, and Laterals, and the overall design will meet or exceed Section 7, "Test Methods and Requirements" of ASTM C-923.

The connector shall be sized specifically for the type of pipe being used and shall be installed in accordance with the recommendations of the manufacturer.

INSTALLATION INSTRUCTIONS

STEP 1:

Confirm that the pipe surface is smooth, clean and free of foreign materials, chips, gouges and form seams due to manufacturing or handling. Slightly bevel any sharp or blunt edges caused by the cutting of the pipe.

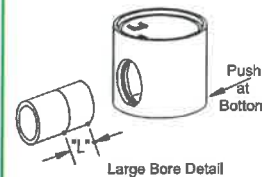

STEP 2:

Lubricate the connector and the entire section of the pipe that will be inserted into the connector. The chart below lists A-LOK's minimum lubrication length "L".

PIPE SIZE	MIN. LUBRICATION LENGTH "L"
4" - 15"	12"
18" - 18"	18"
21" & Larger	24"

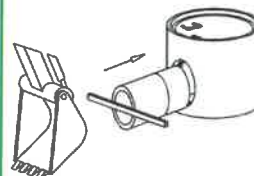

STEP 3:

Center the pipe and connector square to each other and insert the pipe into the connector using a bar or back hoe depending on the size. Once the pipe is coupled with the connector, deflect the structure or pipe to achieve the proper angle.

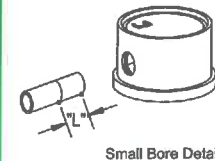

WARNING

To ensure the A-LOK X-CEL Connector remains a flexible watertight connector, it is A-LOK Products, Inc. strong recommendation that no mortar be placed between the pipe and wall of the concrete structure. The use of mortar in this area would decrease the effectiveness of the connector to compensate for shear caused by settlement or ground movement.

NOTE:

To find approximate subgrade, measure from the outside base of the structure to the junction of the connector and flat spot. Then add the wall thickness of the pipe plus 1/4 inch.

CAUTION:

When installing pipe stubs for future pipeline installation, all stubs must be properly restrained to prevent any movement by means other than the **A•LOK X-CEL Connector**.

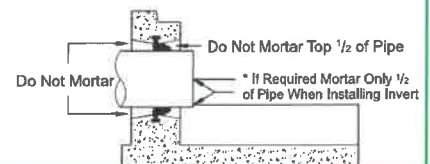



EZ-WRAP

EXTERIOR BUTYL RUBBER JOINT WRAP

What It Is

EZ-WRAP is an extruded butyl adhesive tape designed to provide high strength, watertight seals on properly primed concrete surfaces and concrete structure joints of any kind. The butyl compound is soft, tacky and bonded to either a plastic backing or an EPDM rubber backing. Both kinds of tape are wound in rolls on a release liner for easy application.



Why It's Better

- High quality butyl rubber base
- Available with EPDM Rubber or HDPE Plastic backing
- All-weather performance
- Good adhesion to dry concrete, commonly specified concrete coatings, steel, glass, or painted surfaces
- Coated release paper for easy installation
- Long service life
- Primers recommended for use on damp, contaminated, or difficult surfaces

How It Performs

EZ-WRAP BUTYL JOINT WRAP meets or exceeds all requirements of the following Standards, Specifications and/or Test Methods:

ASTM C 877 (Type III) - Standard Specification for External Sealing Bands for Concrete Pipe, Manholes, and Precast Box Sections

Typical Applications

- Sanitary Manhole Joints
- Grade Ring Joints
- Stormwater Manhole Joints
- Irrigation and Drainage Systems
- Box Culverts
- Elliptical/Arch Pipe
- Architectural Foundations
- Underground Utility Vaults
- Stormwater Treatment Structures
- Stormwater Inlet Structures
- On-Site Treatment Tanks
- Grease Interceptors
- Wet Wells
- Concrete Bridge Spans

Press-Seal believes all information is accurate as of its publication date. Information, specifications, and prices are all subject to change without notice. Press-Seal is not responsible for any inadvertent errors. Copyright 2010.





EZ-WRAP

SPECIFICATION and SELECTION GUIDE

BUTYL JOINT WRAP WITH PLASTIC BACKING

The joints and/or joining surfaces of the structures shall be sealed with a butyl-rubber-based tape. The material shall be EZ-WRAP Plastic as supplied by PRESS-SEAL GASKET CORPORATION, Fort Wayne, Indiana, or approved equal. The butyl component of the tape shall consist of 50% (min.) butyl rubber, shall contain 2% or less volatile matter, and shall be .050" thick. The backing component shall be high-density polyethylene film. A release paper may be utilized.

For manholes, the tape width shall be 6" wide. The tape shall be overlapped at least twice its width. The tape shall not be stretched during application. Primer and/or adhesive as recommended by the tape supplier shall be employed for adverse, critical, or other applications.

Testing of joints and compliance with construction requirements shall be conducted in strict conformance with the requirements of the sealant supplier.

BUTYL JOINT WRAP WITH RUBBER BACKING

The joints and/or joining surfaces of the structures shall be sealed with a butyl-rubber-based tape. The material shall be EZ-WRAP Rubber as supplied by PRESS-SEAL GASKET CORPORATION, Fort Wayne, Indiana, or approved equal. The butyl component of the tape shall consist of 50% (min.) butyl rubber, shall contain 2% or less volatile matter, and shall be .030" thick. The backing component shall be EPDM rubber, and shall be .045" thick. A release paper may be utilized.

For manholes, the tape width shall be 6" wide. The tape shall be overlapped at least twice its width. The tape shall not be stretched during application. Primer and/or adhesive as recommended by the tape supplier shall be employed for adverse, critical, or other applications.

Testing of joints and compliance with construction requirements shall be conducted in strict conformance with the requirements of the sealant supplier.

EZ-WRAP PLASTIC

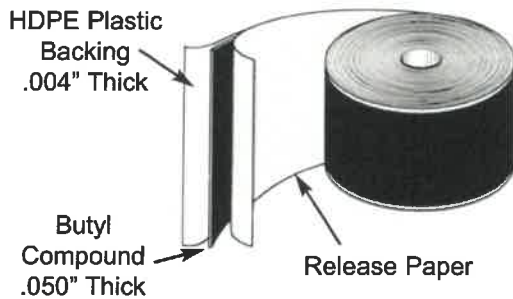

Width	Length	Backing	Part Number
6"	100'	HDPE	276.773.6
9"	100'	HDPE	276.773.9
12"	50'	HDPE	276.773.12

EZ-WRAP RUBBER

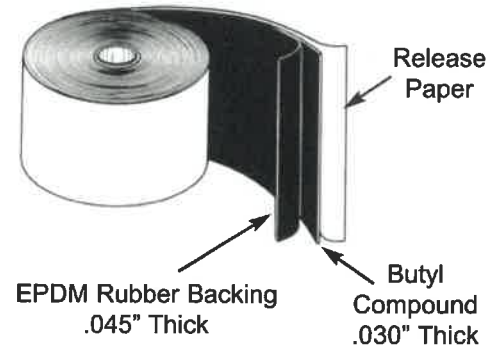

Width	Length	Backing	Part Number
6"	100'	EPDM	276.911.6
9"	100'	EPDM	276.511.9
12"	50'	EPDM	276.911.12

ALSO AVAILABLE: EZ-WRAP PAKS are pre-cut packages of EZ-WRAP designed specifically to seal manhole joints. Each **EZ-WRAP PAK** includes an easy-to-use spray adhesive and pre-cut wraps for standard 48", 60", or 72" manhole joints.

- NOTE:**
- EZ-WRAP is designed to be used with EZ-STIK No. 4 primer, or our spray adhesive
 - EZ-WRAP should not be stretched during installation

If you have any questions, please contact our Customer Service Department or your Press-Seal representative.

Press-Seal believes all information is accurate as of its publication date. Information, specifications, and prices are all subject to change without notice. Press-Seal is not responsible for any inadvertent errors. Copyright 2010.





EZ-STIK

PREMIUM BUTYL JOINT SEALANT

What It Is

EZ-STIK is a premium preformed butyl joint sealant that is supplied in rope form. Containing a higher proportion of butyl rubber, EZ-STIK is carefully blended from uncured butyl rubber and other solids and will not shrink, crack, or dry out. Although clean to handle, it provides excellent adhesion and cohesion to a wide variety of surfaces - concrete, metal, most concrete coatings, glass, wood, and painted surfaces.

Why It's Better

- Increased proportion of butyl rubber content
- Premium packaging
- Wide variety of sizes and styles
- All-weather performance
- Good adhesion to dry concrete, commonly specified concrete coatings, steel, glass, or painted surfaces
- Coated release paper for easy installation
- Long service life
- Cohesive properties allow for joint movement
- Compatible for use with rubber O-Ring designs
- Low moisture vapor transmission rate (MVTR)
- Special primers available for use on damp, contaminated, or difficult surfaces

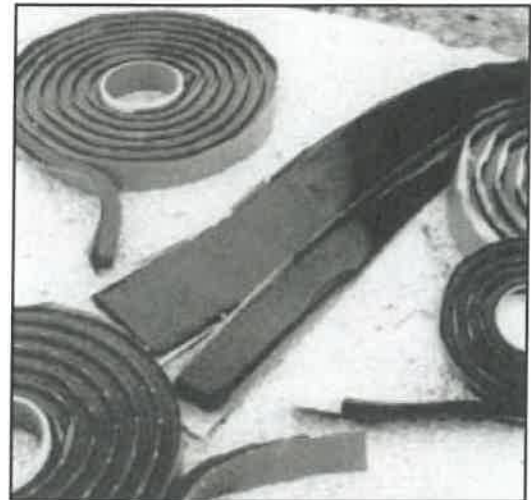

How It Performs

EZ-STIK BUTYL JOINT SEALANT meets or exceeds all requirements of the following Standards, Specifications and/or Test Methods:

ASTM C 990 - Standard Specification for Joints for Concrete Pipe, Manholes, and Precast Box Sections Using Preformed Flexible Joint Sealants; Section 6.2 Butyl Rubber Sealants

EPA Method 524.2 - Detection Method for Drinking Water Volatile Organic Compounds

AASHTO M 198 - Joints for Circular Concrete Sewer and Culvert Pipe Using Flexible Watertight Gaskets

Typical Applications

- | | |
|-----------------------------------|-----------------------------------|
| • Sanitary Manhole Joints | • Underground Utility Vaults |
| • Stormwater Manhole Joints | • Stormwater Treatment Structures |
| • Irrigation and Drainage Systems | • Stormwater Inlet Structures |
| • Box Culverts | • On-Site Treatment Tanks |
| • Elliptical/Arch Pipe | • Grease Interceptors |
| • Architectural Foundations | • Wet Wells |

Press-Seal believes all information is accurate as of its publication date. Information, specifications, and prices are all subject to change without notice. Press-Seal is not responsible for any inadvertent errors. Copyright 2008





EZ-STIK

SPECIFICATION and SELECTION GUIDE

Submittal Specification

The joints and/or joint surfaces of the structures shall be sealed with a butyl-rubber-based preformed flexible sealant conforming to ASTM C-990, paragraph 6.2. The material shall comply with AASHTO M198 for Type B Gaskets, and shall meet the testing requirements of EPA Method 524.2 for Drinking Water Volatile Organic Compounds.

The material shall be EZ-STIK as supplied by PRESS-SEAL GASKET CORPORATION, Fort Wayne, Indiana, or approved equal. The butyl material shall consist of 50% (min.) butyl rubber and shall contain 2% or less volatile matter.

For preformed joint sealants, the sealant shall be sized such that the joint is filled to 50% (min.) of its annular volume when fully assembled, and the sealant shall have the ends kneaded together at the overlap. Primer and/or adhesive as recommended by the sealant supplier shall be employed for adverse, critical, or other applications.

Testing of joints and compliance with construction requirements shall be conducted in strict conformance with the requirements of the sealant supplier.

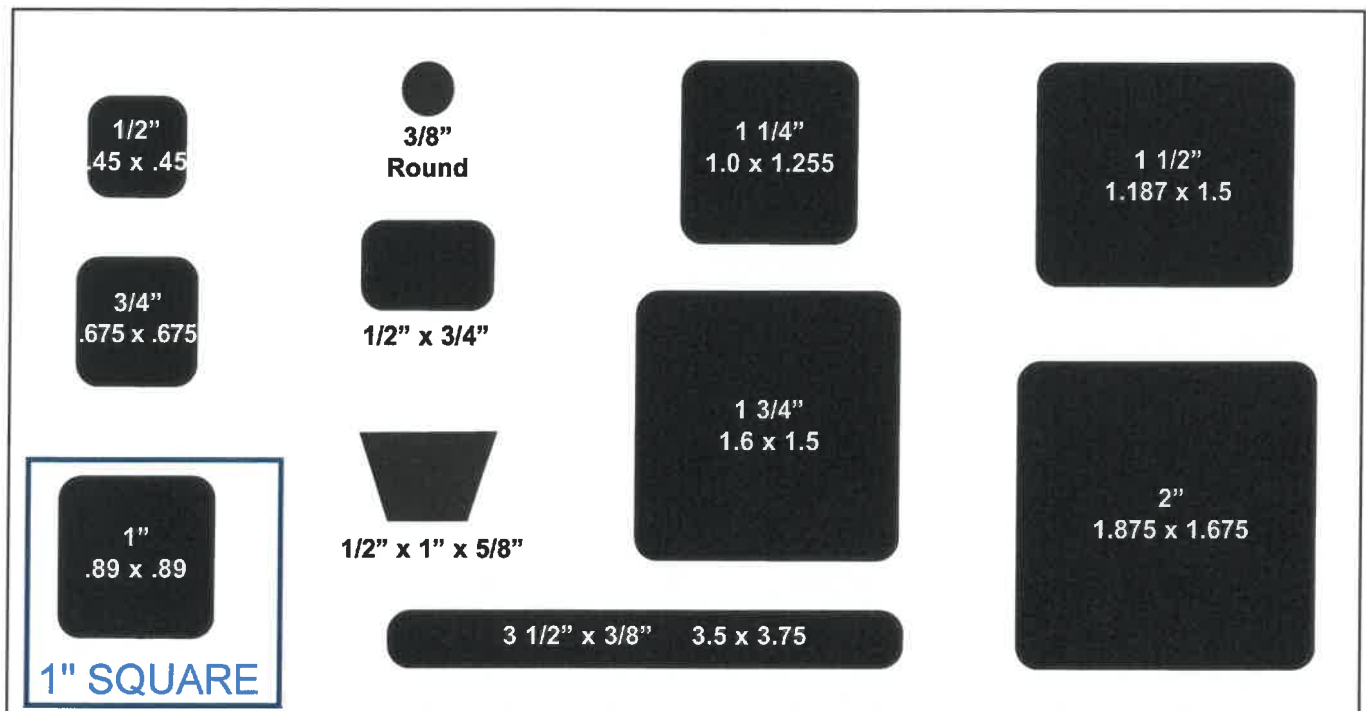

Custom Sizes Available Upon Request

Also Available in Trowelable Bulk and Easy to Pump Bulk

All sizes sold 40 cartons per pallet. All pallets are shrink wrapped for outside storage. Quantity discounts available - contact our Customer Service Department.

Press-Seal believes all information is accurate as of its publication date. Information, specifications, and prices are all subject to change without notice. Press-Seal is not responsible for any inadvertent errors. Copyright 2008





Description

EZ-STIK is a butyl-rubber-based sealant designed to be permanently flexible, tacky and resistant to moisture and deterioration by exposure to dilute chemical solutions. EZ-STIK meets ASTM C-990, Section 6.2 requirements for Butyl Rubber Sealant, EPA Method 524.2 for Drinking Water Volatile Organic Compounds and AASHTO M198 for Type B Gaskets.

Typical Properties

The following values represent typical test results and are manufacturing specifications.

	<u>SPEC.</u>	<u>REQUIRED</u>	<u>EZ-STIK</u>
Butyl Rubber (Hydrocarbon Content %)	ASTM D4	50% min.	62%
Ash Inert Mineral Filler %	AASHTO T111	30% min.	45-48%
Volatile Matter (AASHTO T47)	ASTM D6	2% max.	0.5-1.0%
Specific Gravity @ 77°F (AASHTO T229)	ASTM D71	1.15 - 1.50	1.25 - 1.35
Ductility @ 77°F, cm (AASHTO T51)	ASTM D113	5.0 min.	meets requirement
Flash Point C.O.C.	ASTM D92	350° min.	375°F
Fire Point C.O.C.	ASTM D92	375° min.	385°F
Compression Test			
@77°F, lbf/in ³	ASTM C972	100 max.	40 - 55 lb-ft/in ³
@32°F, lbf.in ³		200 max.	130 - 160 lb-ft/in ³
Low Temperature Flexibility			
@-10°F	ASTM C765	180° bend, no cracking, nor loss of adhesion.	Pass - no cracking or adhesion loss.
Elevated Temperature Flexibility			
14 days @ 157°F	ASTM C776	No sag, nor change in extruded shape.	Pass - no sag or shape change.
Adhesion After Impact	ASTM C776-84	No greater loss than 50% of adhesion.	Pass - no loss of adhesion.
Cone Penetration			
@ 77°F, dmm	ASTM D217	50 - 100 dmm	55 - 85 dmm
@ 32°F, dmm		40 min.	45 - 55 dmm
Chemical Resistance		No deterioration, no cracking, no swelling.	Pass - no visible change after 30 days immersion in 5% solutions HCl, H ₂ SO ₄ , NaOH, KOH, H ₂ S

Press-Seal believes all information is accurate as of its publication date. Information, specifications, and prices are all subject to change without notice. Press-Seal is not responsible for any inadvertent errors. Copyright 2007





Blackhawk™

BH5011 Liquid Asphalt Coating Data Sheet



DESCRIPTION:

Blackhawk Liquid Asphalt Coating is a liquefied asphalt damp proofing compound formulated to be easily applied by roller brush or spray equipment. Blackhawk Liquid Asphalt Coating can be used as a primer on surfaces to receive Blackhawk Pipe Joint Mastic, Hawk-Seal, and Hawk-Wrap, or as a coating. It can be brushed, rolled, or sprayed on surface and dries to a tough, durable, and water-deterring layer that maintains excellent performance over a wide range of temperatures and conditions.

USES:

Blackhawk Liquid Asphalt Coating is used to create an impermeable, reinforcing, and water-deterring layer. Blackhawk Liquid Asphalt Coating can be used on surfaces below and above grade, interior, and exterior, wall, pipe, and cavity situations.

SURFACE PREPARATION:

Surface must be clean, dry and free from oil, grease, dirt, dust, and all other loose impediments to ensure excellent adhesion.

APPLICATION:

Apply to surface by brush, spray, or roller application. Material is ready to use as supplied. Do not thin with additional solvents.

BRUSH APPLICATION:

Apply with a wide fiber brush in order to create a smooth uniform film.

ROLLER APPLICATION:

Use appropriate roller size to cover the particular surface to be coated. Dip the entire head of roller into coating and allow dripping for a few seconds before use.

SPRAY APPLICATION:

Utilize a standard heavy-duty airless spray pump. Consult spray equipment manufacturers for details regarding pump ratio, spray tip, and hose requirements. Allow film to cure for at least 24 to 48 hours.

COVERAGE RATE:

Recommended coverage rate is 1 gallon per 300 square feet. Application rates will vary depending upon the surface to be covered. (16-24 mils per coat)

PACKAGING:

Available in 5 gallon pails, 55 gallon drums, and 275 gallon plastic totes.

CARE OF TOOLS:

Dried material on equipment and brushes may be cleaned and removed with mineral spirits.

CAUTION:

For industrial use only. Keep out of reach of children. Dispose of empty containers in accordance with all local, state and federal regulations. Read Material Safety Data Sheet (MSDS) before using this product.



A Division of Ergon Asphalt & Emulsions, Inc. | P.O. Box 1639, Jackson, MS 39215-1639
913-371-1354 Fax | 877-98ARMOR | ergonarmor.com



BlackhawkTM

BH5011 Liquid Asphalt Coating Data Sheet

CHEMICAL RESISTANCE:

- Acids
- Alkaline
- Salts

SPECIFICATIONS:

- ASTM D41
- ASTM D449 Type I

PHYSICAL PROPERTIES

Color	Black
Weight per gallon	7.8 lbs
Cure Time	24 hours and can vary with climatic conditions
Application	Brush/Roll/Spray
Service Temp. Range	20° to 160°F
VOC Content	350 grams/liter

ORDERING INFORMATION

For additional information, prices, or to place an order, please contact your ErgonArmor sales representative. If you do not know the name of your sales representative, call 877-98ARMOR.

Data Sheet Revised July 2009

All statements, technical information, and recommendations contained herein are based on tests we believe to be reliable, but the accuracy or completeness thereof is not guaranteed, and the following is made in lieu of all warranties, express or implied. Sellers and manufacturers only obligation shall be to replace such quantity of the product proved to be defective. Neither seller nor manufacturer shall be liable for any injury, loss or damage, direct or consequential, arising out of the use of or the inability to use the product. Before using, user shall determine the suitability of the product for the intended use, and user assumes all risk and liability whatsoever therewith. No statement or recommendation not contained herein shall have any force or effect unless in an agreement signed by officers of seller and manufacturer.



A Division of Ergon Asphalt & Emulsions, Inc. | P.O. Box 1639, Jackson, MS 39215-1639
913-371-1354 Fax | 877-98ARMOR | ergonarmor.com