

Re: 251334
REUNION AT BLACKWELL/ Bldg D

The truss drawing(s) referenced below have been prepared by MiTek USA, Inc. under my direct supervision based on the parameters provided by Heartland Truss, LLC..

Pages or sheets covered by this seal: I78869129 thru I78869132
My license renewal date for the state of Missouri is December 31, 2026.

Missouri COA: Engineering 001193

RELEASE FOR CONSTRUCTION
AS NOTED ON PLANS REVIEW
DEVELOPMENT SERVICES
LEE'S SUMMIT, MISSOURI
03/05/2026 3:17:09



January 7, 2026

Lu, Jie, Engineer

IMPORTANT NOTE: The seal on these truss component designs is a certification that the engineer named is licensed in the jurisdiction(s) identified and that the designs comply with ANSI/TPI 1. These designs are based upon parameters shown (e.g., loads, supports, dimensions, shapes and design codes), which were given to MiTek or TRENCO. Any project specific information included is for MiTek's or TRENCO's customers file reference purpose only, and was not taken into account in the preparation of these designs. MiTek or TRENCO has not independently verified the applicability of the design parameters or the designs for any particular building. Before use, the building designer should verify applicability of design parameters and properly incorporate these designs into the overall building design per ANSI/TPI 1, Chapter 2.

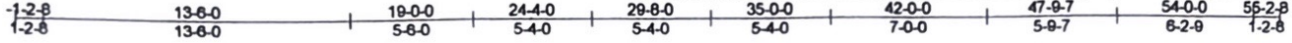

REPAIR.
REMOVE 0-1-8 FROM Q-R

LUMBER AND CONNECTOR PLATES (SHOWN DASHED) TO BE CUT CLEANLY AND ACCURATELY AND THE REMAINING PLATE(S) MUST BE FULLY EMBEDDED AND UNDISTURBED.
6x8 PLATE AT JT. Q MUST REMAIN INTACT WITHOUT DISTURBANCE.

Scale = 1:102.7

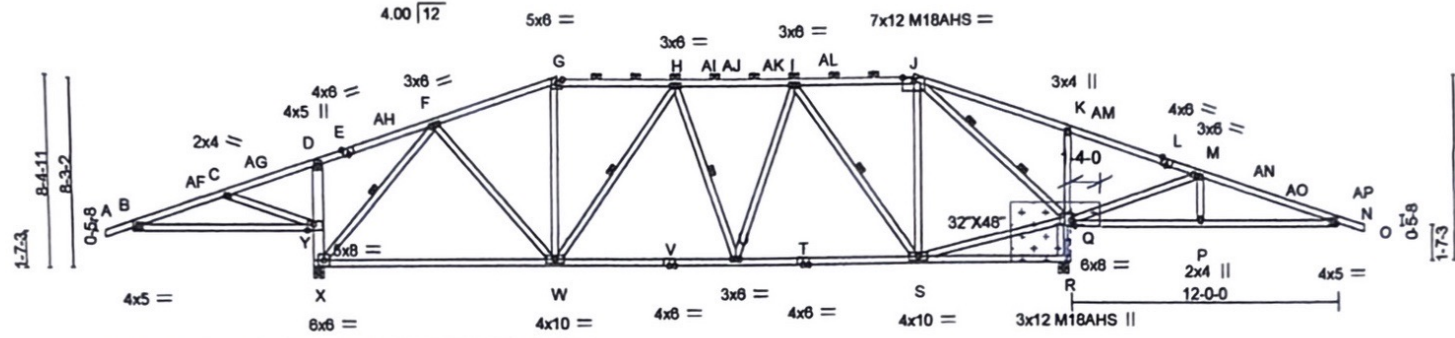

ATTACH 7/16" OSB GUSSET (7/16" RATED SHEATHING 24/16 EXP 1) TO EACH FACE OF TRUSS WITH (0.131" X 2.5" MIN.) NAILS PER THE FOLLOWING NAIL SCHEDULE:
2 X 3'S - 2 ROWS, 2 X 4'S - 3 ROWS, 2 X 6'S AND LARGER - 4 ROWS: SPACED @ 4" O.C.
NAILS TO BE DRIVEN FROM BOTH FACES. STAGGER SPACING FROM FRONT TO BACK FACE FOR A NET 2" O.C. SPACING IN EACH COVERED TRUSS MEMBER. USE 2" MEMBER END DISTANCE.



INSTALL 2 X 4 SPF/DF/SP NO 2; CUT TO FIT TIGHT TRIM CORNER OF NEW MEMBER TO AVOID DAMAGE TO EXISTING CONNECTOR PLATES.

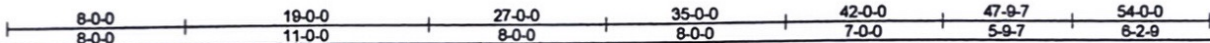

Plate Offsets (X,Y)- [E:0-3-0,Edge], [J:0-6-0,0-1-11], [L:0-3-0,Edge], [Q:0-2-0,0-2-12], [Y:0-3-4,0-3-4]

LOADING (psf)	SPACING-	2-0-0	CSI.	DEFL.	In (loc)	V/defl	L/d	PLATES	GRIP
TCLL 20.0 (Roof Snow=20.0)	Plate Grip DOL	1.15	TC 0.98	Vert(LL)	-0.32	W-X	>999	MT20	244/190
TCDL 10.0	Lumber DOL	1.15	BC 0.99	Vert(CT)	-0.67	W-X	>603	M18AHS	186/179
BCLL 10.0	Rep Stress Incr	YES	WB 0.91	Horz(CT)	0.04	R	n/a		
BCDL 10.0	Code IRC2018/TPI2014		Matrix-MS	Wind(LL)	0.06	W-X	>999		
								Weight 325 lb	FT = 20%

LUMBER-
TOP CHORD 2x4 SP No.2 *Except*
J-L,L-O: 2x4 SP 1650F 1.5E
BOT CHORD 2x4 SP No.2
WEBS 2x4 SP No.3 *Except*
D-X: 2x6 SP No.1, K-R: 2x4 SP No.2

BRACING-
TOP CHORD Structural wood sheathing directly applied or 2-2-0 oc purlins, except end verticals, and 2-0-0 oc purlins (4-8-10 max.): G-J, D-X, K-R.
Except:
2-2-0 oc bracing: X-Y
3-3-0 oc bracing: Q-R
BOT CHORD Rigid ceiling directly applied or 2-2-0 oc bracing.
WEBS 1 Row at midpt F-X, H-W, H-U, I-S
2 Rows at 1/3 pts J-Q

REACTIONS. (lb/size) X=1972/0-5-8, R=2493/0-5-8
Max Horz X=227(LC 12)
Max Uplift X=590(LC 8), R=759(LC 9)
Max Grav X=2311(LC 39), R=2920(LC 39)

FORCES. (lb) - Max. Comp./Max. Ten. - All forces 250 (lb) or less except when shown.
TOP CHORD B-AF=460/661, C-AF=448/713, C-AG=685/1247, D-AG=674/1361, D-E=367/742, E-AH=362/812, F-AH=349/886, F-G=1155/208, G-H=1078/221, H-AJ=1293/241, AI-AJ=1293/241, AJ-AK=1293/241, AK-AL=1293/241, I-AL=1293/241, I-J=607/174, J-K=809/2032, K-AM=893/2075, L-AM=894/2052, L-M=913/1915, M-AN=496/942, AN-AO=496/923, AO-AP=506/844, N-AP=514/844, X-Y=929/384, D-Y=602/207, Q-R=2825/936, K-Q=697/223
BOT CHORD B-Y=617/469, W-X=136/613, V-W=140/1346, U-V=140/1346, T-U=122/1190, S-T=122/1190, P-Q=800/542, N-P=800/542
WEBS F-W=71/784, F-X=1718/469, H-W=478/115, I-U=81/470, I-S=1034/253, J-S=195/975, Q-S=30/721, M-P=128/291, M-Q=1154/488, J-Q=2572/862, C-Y=686/301

- NOTES-**
- 1) Wind: ASCE 7-16; Vult=115mph (3-second gust) Vasd=91mph; TCDL=6.0psf; BCDL=6.0psf; h=20ft; Cat. II; Exp C; Enclosed; MWFRS (envelope) gable end zone and C-C Exterior(2E) -1-2-8 to 3-11-12, Interior(1) 3-11-12 to 11-4-6, Exterior(2R) 11-4-6 to 26-7-10, Interior(1) 26-7-10 to 35-0-0, Exterior(2E) 35-0-0 to 42-7-10, Interior(1) 42-7-10 to 49-9-11, Exterior(2E) 49-9-11 to 55-2-8 zone; cantilever left and right exposed; end vertical left and right exposed; C-C for members and forces & MWFRS for reactions shown; Lumber DOL=1.33 plate grip DOL=1.33
 - 2) TCLL: ASCE 7-16; Pt=20.0 psf (Lum DOL = 1.15 Plate DOL = 1.15); Is=1.0; Rough Cat C; Fully Exp.; Ce=0.9; Cs=1.00; Ct=1.10
 - 3) Unbalanced snow loads have been considered for this design.
 - 4) This truss has been designed for greater of min roof live load of 16.0 psf or 2.00 times flat roof load of 20.0 psf on overhangs non-concurrent with other live loads.
 - 5) Provide adequate drainage to prevent water ponding.
 - 6) All plates are MT20 plates unless otherwise indicated.
 - 7) This truss has been designed for a 10.0 psf bottom chord live load nonconcurrent with any other live loads.
 - 8) Provide mechanical connection (by others) of truss to bearing plate capable of withstanding 590 lb uplift at joint X and 759 lb uplift at joint R.
 - 9) This truss is designed in accordance with the 2018 International Residential Code sections R502.11.1 and R802.10.2 and referenced standard ANSI/TPI 1



January 7, 2026

Continued on page 2

WARNING - Verify design parameters and READ NOTES ON THIS AND INCLUDED MITEK REFERENCE PAGE MI-7473 rev. 1/2/2023 BEFORE USE.
Design valid for use only with MiTek® connectors. This design is based only on parameters shown, and is for an individual building component, not a truss system. Before use, the building designer must verify the applicability of design parameters and properly incorporate this design into the overall building design. Bracing indicated is to prevent buckling of individual truss web and/or chord members only. Additional temporary and permanent bracing is always required for stability and to prevent collapse with possible personal injury and property damage. For general guidance regarding the fabrication, storage, delivery, erection and bracing of trusses and truss systems, see ANSI/TPH Quality Criteria, and DSB-22 available from Truss Plate Institute (www.tpinst.org) and BCSI Building Component Safety Information available from the Structural Building Component Association (www.sbcsc.com)



Job	Truss	Truss Type	Qty	Ply	REUNION AT BLACKWELL/ Bldg D
251334	ASA	Hip	1	1	Job Reference (optional)

Heartland Truss, LLC, Plattsburg, MO.

25 4 0 9 Nov 25 2025 MiTek Industries, Inc. Wed Jan 7 09:07:32 2026 Page 2
 ID:qUFu7WFWuLTPCLe5ksDb08y7L5N-ABBGEgbl8rdiOppOVipzrG6M1p4_2q7PpUvW4zxo79

NOTES-

10) Graphical purlin representation does not depict the size or the orientation of the purlin along the top and/or bottom chord.

LOAD CASE(S) Standard

WARNING - verify design parameters and READ NOTES ON THIS AND INCLUDED MITEK REFERENCE PAGE MI-7473 rev. 1/2/2023 BEFORE USE.

Design valid for use only with MiTek® connectors. This design is based only upon parameters shown, and is for an individual building component, not a truss system. Before use, the building designer must verify the applicability of design parameters and properly incorporate this design into the overall building design. Bracing indicated is to prevent buckling of individual truss web and/or chord members only. Additional temporary and permanent bracing is always required for stability and to prevent collapse with possible personal injury and property damage. For general guidance regarding the fabrication, storage, delivery, erection and bracing of trusses and truss systems, see ANS/TP11 Quality Criteria, and DSB-22 available from Truss Plate Institute (www.tpinst.org) and BCSI Building Component Safety Information available from the Structural Building Component Association (www.sbcsc.com)

MiTek

16023 Swingley Ridge Rd.
 Chesterfield, MO 63017
 314 434 1200 / MiTek-US.com

Job	Truss	Truss Type	Qty	Ply	REUNION AT BLACKWELL/ Bldg D	178869130
251334	ABA	Hip	1	1		

Heartland Truss, LLC., Plattsburg, MO - 64477.

25.4.0 s Dec 15 2025 MiTek Industries, Inc. Tue Jan 6 12:46:18 2026 Page 1
 ID:qUFu7WFUwLTPCLe5ksDb08y7L5N-xSFHbbFyJHjta3JY?g7VJNjddqgqHW7UV7az8zy403

1-2-8	4-2-9	8-0-0	12-6-0	17-0-0	23-7-7	30-4-9	37-0-0	42-0-0	47-9-7	54-0-0	55-2-8
1-2-8	4-2-9	3-9-7	4-6-0	4-6-0	6-7-7	6-9-3	6-7-7	5-0-0	5-9-7	6-2-9	1-2-8

Scale = 1.105 6

REFER TO MITEK REFERENCE NUMBER 178869129 FOR REPAIR DETAIL

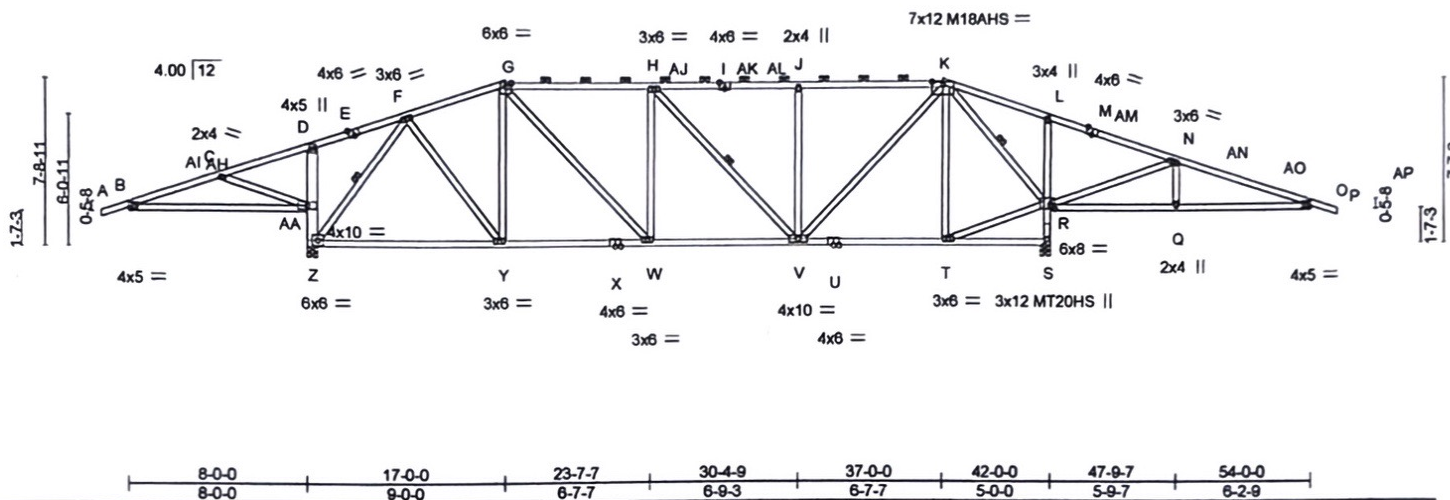

LOADING (psf)	SPACING-	CSI.	DEFL.	PLATES	GRIP
TCLL 20.0	2-0-0	TC 0.91	Vert(LL) -0.14 Y-Z >999 360	MT20	244/190
(Roof Snow=20.0)	Plate Grip DOL 1.15	BC 0.71	Vert(CT) -0.31 Y-Z >999 240	MT20HS	187/143
TCDL 10.0	Lumber DOL 1.15	WB 0.96	Horz(CT) 0.04 S n/a n/a	M18AHS	186/179
BCLL 10.0	Rep Stress Incr YES	Matrix-MS	WInd(LL) 0.05 V-W >999 240	Weight: 326 lb	FT = 20%
BCDL 10.0	Code IRC2018/TPI2014				

LUMBER-	BRACING-
TOP CHORD 2x4 SP 1650F 1.5E *Except* G-I, I-K: 2x4 SP No.2	TOP CHORD Structural wood sheathing directly applied or 6-0-0 oc purlins, except end verticals, and 2-0-0 oc purlins (2-2-0 max.): G-K, D-Z, L-S. Except: 2-9-0 oc bracing: R-S 6-0-0 oc bracing: Z-AA
BOT CHORD 2x4 SP No.2	BOT CHORD Rigid ceiling directly applied or 4-10-5 oc bracing.
WEBS 2x4 SP No.3 *Except* D-Z: 2x6 SP 2400F 2.0E	WEBS 1 Row at midpt F-Z, H-V, K-R

REACTIONS. (size) Z=0-5-8, S=0-5-8
 Max Horz Z=216(LC 12)
 Max Uplift Z=596(LC 8), S=768(LC 9)
 Max Grav Z=2274(LC 39), S=2873(LC 39)

FORCES. (lb) - Max. Comp./Max. Ten. - All forces 250 (lb) or less except when shown.
 TOP CHORD B-C=459/789, C-D=687/1527, D-F=367/886, F-G=1160/195, G-H=1630/267, H-J=1406/257, J-K=1409/259, K-L=840/2233, L-N=921/2274, N-O=510/1063, Z-AA=934/379, D-AA=577/201, R-S=2811/885, L-R=572/184
 BOT CHORD B-AA=669/468, Y-Z=103/547, W-Y=122/1108, V-W=156/1627, T-V=492/586, Q-R=907/538, O-Q=907/538
 WEBS C-AA=773/305, F-Z=1680/405, F-Y=131/968, G-Y=588/202, G-W=145/776, H-W=455/197, H-V=400/128, J-V=693/194, K-V=269/1443, K-T=86/326, R-T=470/607, K-R=2545/848, N-R=1251/503, N-Q=127/290

- NOTES-
- 1) Wind: ASCE 7-16; Vult=115mph (3-second gust) Vasd=91mph; TCDL=6.0psf; BCDL=6.0psf; h=20ft; Cat. II; Exp C; Enclosed; MWFRS (envelope) gable end zone and C-C Exterior(2E) -1-2-8 to 3-11-12, Interior(1) 3-11-12 to 17-0-0, Exterior(2E) 17-0-0 to 24-7-10, Interior(1) 24-7-10 to 37-0-0, Exterior(2E) 37-0-0 to 44-7-10, Interior(1) 44-7-10 to 49-9-11, Exterior(2E) 49-9-11 to 55-2-8 zone; cantilever left and right exposed; end vertical left and right exposed; C-C for members and forces & MWFRS for reactions shown; Lumber DOL=1.33 plate grip DOL=1.33
 - 2) TCLL: ASCE 7-16; Pf=20.0 psf (Lum DOL = 1.15) Plate DOL = 1.15; Is=1.0; Rough Cat C; Fully Exp.; Ce=0.9; Cs=1.00; Ct=1.10
 - 3) Unbalanced snow loads have been considered for this design.
 - 4) This truss has been designed for greater of min roof live load of 16.0 psf or 2.00 times flat roof load of 20.0 psf on overhangs non-concurrent with other live loads.
 - 5) Provide adequate drainage to prevent water ponding.
 - 6) All plates are MT20 plates unless otherwise indicated.
 - 7) This truss has been designed for a 10.0 psf bottom chord live load nonconcurrent with any other live loads.
 - 8) Provide mechanical connection (by others) of truss to bearing plate capable of withstanding 100 lb uplift at joint(s) except (I=lb) Z=596, S=768.
 - 9) This truss is designed in accordance with the 2018 International Residential Code sections R502.11.1 and R802.10.2 and referenced standard ANSI/TPI 1.
 - 10) Graphical purlin representation does not depict the size or the orientation of the purlin along the top and/or bottom chord.



January 7, 2026

WARNING - Verify design parameters and READ NOTES ON THIS AND INCLUDED MITEK REFERENCE PAGE MI-7473 rev. 1/2/2023 BEFORE USE.

Design valid for use only with MiTek® connectors. This design is based only upon parameters shown, and is for an individual building component, not a truss system. Before use, the building designer must verify the applicability of design parameters and properly incorporate this design into the overall building design. Bracing indicated is to prevent buckling of individual truss web and/or chord members only. Additional temporary and permanent bracing is always required for stability and to prevent collapse with possible personal injury and property damage. For general guidance regarding the fabrication, storage, delivery, erection and bracing of trusses and truss systems, see ANSI/TPI Quality Criteria, and DSB-22 available from Truss Plate Institute (www.tpinst.org) and BCSI Building Component Safety Information available from the Structural Building Component Association (www.sbcscomponents.com)

MiTek®
 16023 Swingley Ridge Rd.
 Chesterfield, MO 63017
 314.434.1200 / MiTek-US.com

Job	Truss	Truss Type	Qty	Ply	REUNION AT BLACKWELL/ Bldg D	178889131
251334	A7A	Hip	1	1		

Heartland Truss, LLC., Plattsburg, MO - 64477.

25.4.0 s Dec 15 2025 MiTek Industries, Inc. Tue Jan 6 12:46:19 2026 Page 1
 ID:qUFu7WFUwLTPCLe5ksDb08y7LSN-PT7e4dcD0GR8L19GsFWGjsZA19YZkRGj9I7Vbzy402

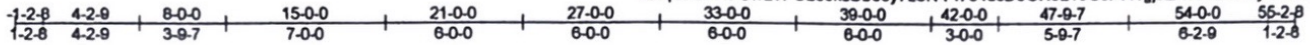

Scale = 1:101.6

REFER TO MITEK REFERENCE NUMBER I78889129 FOR REPAIR DETAIL

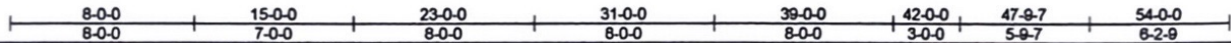
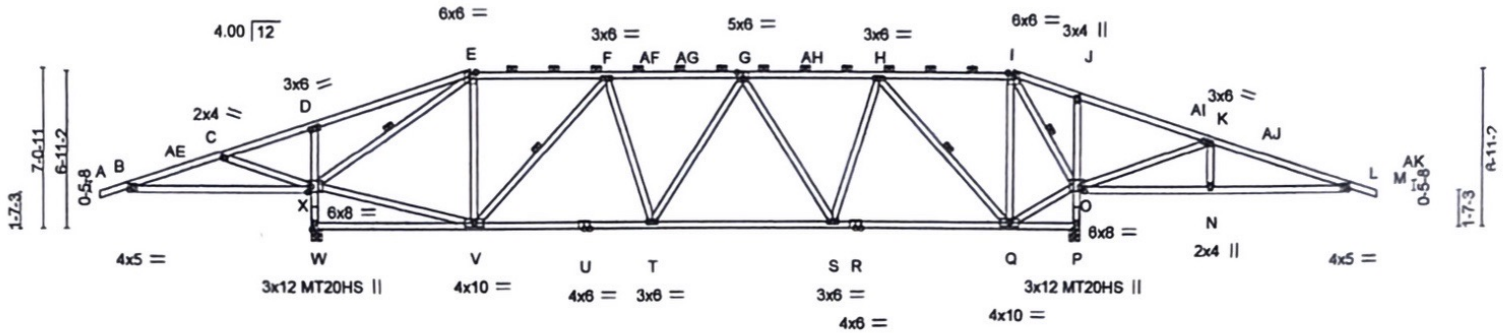

Plate Offsets (X,Y) - [G:0-3-0,0-3-0], [O:0-2-8,0-2-4], [X:0-2-0,0-3-0]

LOADING (psf)	SPACING-	CSL	DEFL.	PLATES	GRIP
TCLL 20.0 (Roof Snow=20.0)	2-0-0 Plate Grip DOL 1.15 Lumber DOL 1.15	TC 0.87 BC 0.79	in (loc) l/defl L/d Vert(LL) -0.16 S-T >999 360 Vert(CT) -0.27 S-T >999 240 Horz(CT) 0.06 P n/a n/a Wind(LL) 0.06 T >999 240	MT20 MT20HS	244/190 187/143
TCDL 10.0	Rep Stress Incr YES	WB 0.99			
BCLL 10.0	Code IRC2018/TPI2014	Matrix-MS			
BCDL 10.0				Weight: 321 lb	FT = 20%

LUMBER-	BRACING-
TOP CHORD 2x4 SP 1650F 1.5E *Except* E-G,G-I: 2x4 SP No.2	TOP CHORD Structural wood sheathing directly applied or 6-0-0 oc purlins, except end verticals, and 2-0-0 oc purlins (3-8-4 max.): E-I, D-W, J-P. Except
BOT CHORD 2x4 SP No.2	BOT CHORD 2-8-0 oc bracing: W-X, O-P
WEBS 2x4 SP No.3	WEBS Rigid ceiling directly applied or 4-3-8 oc bracing. 1 Row at midpt E-X, F-V, H-Q, I-O

REACTIONS. (size) W=0-5-8, P=0-5-8
 Max Horz W=204(LC 12)
 Max Uplift W=598(LC 8), P=776(LC 9)
 Max Grav W=2246(LC 29), P=2837(LC 39)

FORCES. (lb) - Max. Comp./Max. Ten. - All forces 250 (lb) or less except when shown.
 TOP CHORD B-C=475/1055, C-D=670/1702, D-E=583/1652, E-F=1079/183, F-G=1838/251, G-H=1524/245, H-I=342/1000, I-J=856/2443, J-K=928/2518, K-L=509/1286, W-X=214/1634, D-X=634/210, O-P=2834/867, J-O=504/162
 BOT CHORD B-X=921/484, T-V=183/1786, S-T=200/1846, Q-S=339/1313, N-O=1117/536, L-N=1117/536
 WEBS C-X=664/264, V-X=0/1113, E-X=2192/569, E-V=61/772, F-V=1073/199, F-T=49/272, G-T=29/273, G-S=625/207, H-S=83/818, H-Q=1766/338, I-Q=451/1506, O-Q=1098/660, I-O=2672/917, K-O=1278/515, K-N=125/288

- NOTES-
- 1) Wind: ASCE 7-16; Vult=115mph (3-second gust) Vasd=91mph; TCDL=6.0psf; BCDL=6.0psf; h=20ft; Cat. II; Exp C; Enclosed; MWFRS (envelope) gable end zone and C-C Exterior(2E) -1-2-8 to 3-11-12, Interior(1) 3-11-12 to 15-0-0, Exterior(2E) 15-0-0 to 22-7-10, Interior(1) 22-7-10 to 39-0-0, Exterior(2E) 39-0-0 to 46-7-10, Interior(1) 46-7-10 to 49-9-11, Exterior(2E) 49-9-11 to 55-2-8 zone; cantilever left and right exposed; end vertical left and right exposed; C-C for members and forces & MWFRS for reactions shown; Lumber DOL=1.33 plate grip DOL=1.33
 - 2) TCLL: ASCE 7-16; Pf=20.0 psf (Lum DOL = 1.15 Plate DOL = 1.15); Is=1.0; Rough Cat C; Fully Exp.; Ce=0.9; Cs=1.00; Ct=1.10
 - 3) Unbalanced snow loads have been considered for this design.
 - 4) This truss has been designed for greater of min roof live load of 16.0 psf or 2.00 times flat roof load of 20.0 psf on overhangs non-concurrent with other live loads.
 - 5) Provide adequate drainage to prevent water ponding.
 - 6) All plates are MT20 plates unless otherwise indicated.
 - 7) This truss has been designed for a 10.0 psf bottom chord live load nonconcurrent with any other live loads.
 - 8) Provide mechanical connection (by others) of truss to bearing plate capable of withstanding 100 lb uplift at joint(s) except (jt=lb) W=598, P=776.
 - 9) This truss is designed in accordance with the 2018 International Residential Code sections R502.11.1 and R802.10.2 and referenced standard ANSI/TPI 1.
 - 10) Graphical purlin representation does not depict the size or the orientation of the purlin along the top and/or bottom chord.



January 7, 2026

WARNING - Verify design parameters and READ NOTES ON THIS AND INCLUDED MITEK REFERENCE PAGE MI-7473 rev. 1/2/2023 BEFORE USE.
 Design valid for use only with MiTek® connectors. This design is based only upon parameters shown, and is for an individual building component, not a truss system. Before use, the building designer must verify the applicability of design parameters and properly incorporate this design into the overall building design. Bracing indicated is to prevent buckling of individual truss web and/or chord members only. Additional temporary and permanent bracing is always required for stability and to prevent collapse with possible personal injury and property damage. For general guidance regarding the fabrication, storage, delivery, erection and bracing of trusses and truss systems, see ANSI/TPI1 Quality Criteria, and DSB-22 available from Truss Plate Institute (www.tpiinst.org) and BCSI Building Component Safety Information available from the Structural Building Component Association (www.sbcsccomponents.com)



Job	Truss	Truss Type	Qty	Ply	REUNION AT BLACKWELL/ Bldg D	178869132
251334	FL1	Flat Girder	2	2	Job Reference (optional)	

Hearland Truss, L.L.C., Plattsburg, MO - 64477,

25.4.0 s Dec 15 2025 MiTek Industries, Inc. Tue Jan 6 12:46:20 2026 Page 1
ID:qUFu7WFWwLTPCLe5ksDb08y7L5N-Irh0HzdmaZ7yAJSQz28DwPjPRV0IF7PxpUh11zy401

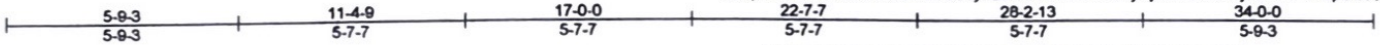

LUMBER AND CONNECTOR PLATES (SHOWN DASHED) TO BE CUT CLEANLY AND ACCURATELY AND THE REMAINING PLATE(S) MUST BE FULLY EMBEDDED AND UNDISTURBED. 6x10 PLATE AT JT. "I" MUST REMAIN INTACT WITHOUT DISTURBANCE.

Scale = 1.57.6

REPAIR:
REMOVE 0-1-8 BY 1-7-3 SECTION OF RIGHT END VERTICAL STARTING AT JOINT J (ONE-PLY)

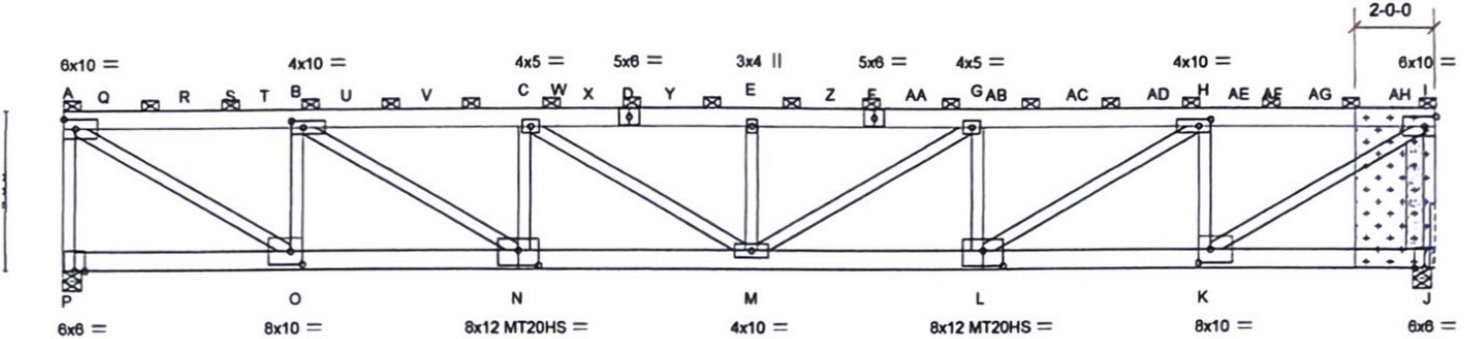

ATTACH < 2 LAYERS > 3/4" PLYWOOD OR OSB GUSSET (23/32" RATED SHEATHING 48/24 EXP 1) TO EACH FACE OF TRUSS WITH (0.131" X 3.0") NAILS PER THE FOLLOWING NAIL SCHEDULE. 2 X 4'S - 3 ROWS, 2 X 6'S AND LARGER - 4 ROWS. SPACED @ 2" O.C. USE 2" MEMBER END DISTANCE. GLUE PLYWOOD LAYERS TOGETHER PRIOR TO ATTACHING TO TRUSS.

INSTALL (2 PLY) 2 X 6 SPF/DF/SP NO.2 CUT TO FIT TIGHT. ATTACH PLYS WITH TWO ROWS OF (0.131 X 3") NAILS SPACED 9" O.C. TRIM CORNER OF NEW MEMBER TO AVOID DAMAGE TO EXISTING CONNECTOR PLATES.

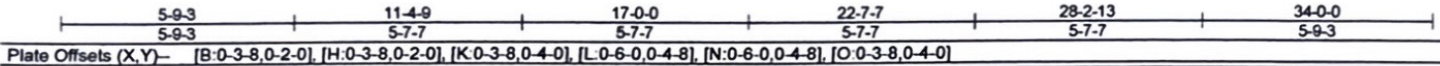

LOADING (psf)	SPACING-	CSL	DEFL.	PLATES	GRIP
TCLL 20.0 (Roof Snow=20.0)	2-0-0 Plate Grip DOL 1.15	TC 0.90	Vert(LL) -0.38 Vert(CT) -0.65	MT20 MT20HS	244/190 187/143
TCDL 10.0	Lumber DOL 1.15	BC 0.78	Horz(CT) 0.10		
BCLL 10.0	Rep Stress Incr NO	WB 0.71	Wind(LL) 0.26		
BCDL 10.0	Code IRC2018/TPI2014	Matrix-MS		Weight: 492 lb	FT = 20%

LUMBER-
TOP CHORD 2x6 SP No.1
BOT CHORD 2x6 SP No.1 *Except*
L-N: 2x6 SP 2400F 2.0E
WEBS 2x4 SP 2400F 2.0E *Except*
A-P,I-J: 2x4 SP No.2, B-O,C-N,E-M,G-L,H-K: 2x4 SP No.3

BRACING-
TOP CHORD 2-0-0 oc purlins (2-11-1 max.); A-I, except end verticals.
BOT CHORD Rigid ceiling directly applied or 10-0-0 oc bracing.

REACTIONS. (size) J=0-5-8, P=0-5-8
Max Horz P=-129(LC 30)
Max Uplift J=-1035(LC 9), P=-1062(LC 8)
Max Grav J=6689(LC 2), P=6787(LC 2)

FORCES. (lb) - Max. Comp./Max. Ten. - All forces 250 (lb) or less except when shown.
TOP CHORD A-P=-6651/1151, A-B=-9083/1486, B-C=-14048/2334, C-E=-15852/2655, E-G=-15852/2655, G-H=-14004/2369, H-I=-8978/1552, I-J=-6555/1130
BOT CHORD N-O=-1481/9083, M-N=-2236/14172, L-M=-2252/14129, K-L=-1410/8978
WEBS A-O=-1789/10614, B-O=-5504/1042, B-N=-1011/5915, C-N=-2996/607, C-M=-350/1986, E-M=-2024/433, G-M=-321/2036, G-L=-3041/590, H-L=-973/5987, H-K=-5438/1001, I-K=-1731/10495

NOTES-

- 2-ply truss to be connected together with 10d (0.131"x3") nails as follows:
Top chords connected as follows: 2x4 - 1 row at 0-9-0 oc, 2x6 - 2 rows staggered at 0-9-0 oc.
Bottom chords connected as follows: 2x6 - 2 rows staggered at 0-9-0 oc.
Webs connected as follows: 2x4 - 1 row at 0-9-0 oc.
- All loads are considered equally applied to all plies, except if noted as front (F) or back (B) face in the LOAD CASE(S) section. Ply to ply connections have been provided to distribute only loads noted as (F) or (B), unless otherwise indicated.
- Wind: ASCE 7-16; Vult=115mph (3-second gust) Vasd=91mph; TCDF=6.0psf; BCDF=6.0psf; h=20ft; Cat II; Exp C; Enclosed; MWFRS (envelope) gable end zone and C-C Corner(3) 0-1-12 to 4-1-12, Exterior(2) 4-1-12 to 29-10-4, Corner(3) 29-10-4 to 33-10-4 zone; cantilever left and right exposed; end vertical left and right exposed; C-C for members and forces & MWFRS for reactions shown; Lumber DOL=1.33 plate grip DOL=1.33
- TCLL: ASCE 7-16; Pf=20.0 psf (Lum DOL = 1.15 Plate DOL = 1.15); Is=1.0; Rough Cat C; Fully Exp.; Ce=0.9; Cs=1.00; Ct=1.10
- Unbalanced snow loads have been considered for this design.
- Provide adequate drainage to prevent water ponding.
- All plates are MT20 plates unless otherwise indicated.
- This truss has been designed for a 10.0 psf bottom chord live load nonconcurrent with any other live loads.
- Bearing at joint(s) J, P considers parallel to grain value using ANSI/TPI 1 angle to grain formula. Building designer should verify capacity of bearing surface.
- Provide mechanical connection (by others) of truss to bearing plate capable of withstanding 100 lb uplift at joint(s) except (J=lb) J=1035, P=1062.
- This truss is designed in accordance with the 2018 International Residential Code sections R502.11.1 and R802.10.2 and referenced standard ANSI/TPI 1.



January 7, 2026

Continued on page 2

WARNING - Verify design parameters and READ NOTES ON THIS AND INCLUDED MITEK REFERENCE PAGE MII-7473 rev. 1/2/2023 BEFORE USE.
Design valid for use only with MiTek® connectors. This design is based only upon parameters shown, and is for an individual building component, not a truss system. Before use, the building designer must verify the applicability of design parameters and properly incorporate this design into the overall building design. Bracing indicated is to prevent buckling of individual truss web and/or chord members only. Additional temporary and permanent bracing is always required for stability and to prevent collapse with possible personal injury and property damage. For general guidance regarding the fabrication, storage, delivery, erection and bracing of trusses and truss systems, see ANSI/TPI1 Quality Criteria, and DSB-22 available from Truss Plate Institute (www.tpinst.org) and BCSI Building Component Safety Information available from the Structural Building Component Association (www.sbcsc.com).

MiTek®
16023 Swingley Ridge Rd.
Chesterfield, MO 63017
314.434.1200 / MiTek-US.com

Job	TRUSS	Truss Type	Qty	Ply	REUNION AT BLACKWELL/ Bldg D	178869132
251334	FL1	Flat Girder	2	2	Job Reference (optional)	

Hearland Truss, LLC., Plattsburg, MO - 64477,

25.4.0 s Dec 15 2025 MiTek Industries, Inc. Tue Jan 6 12:46:20 2026 Page 2
ID:qUFu7WFUwLTPCLe5ksDb08y7L5N-Irh0HzdmaZ7yAJSQz28DwPjPRV0IF7PxpUh11zy401

NOTES-

- 12) Graphical purlin representation does not depict the size or the orientation of the purlin along the top and/or bottom chord.
- 13) Hanger(s) or other connection device(s) shall be provided sufficient to support concentrated load(s) 762 lb down and 222 lb up at 1-0-0, 759 lb down and 226 lb up at 3-0-0, 759 lb down and 226 lb up at 5-0-0, 640 lb down and 147 lb up at 7-0-0, 640 lb down and 147 lb up at 9-0-0, 640 lb down and 147 lb up at 11-0-0, 640 lb down and 147 lb up at 13-0-0, 640 lb down and 147 lb up at 15-0-0, 640 lb down and 147 lb up at 17-0-0, 640 lb down and 147 lb up at 19-0-0, 640 lb down and 147 lb up at 21-0-0, 640 lb down and 147 lb up at 23-0-0, 640 lb down and 147 lb up at 25-0-0, 640 lb down and 147 lb up at 27-0-0, 640 lb down and 147 lb up at 29-0-0, and 640 lb down and 147 lb up at 31-0-0, and 762 lb down and 221 lb up at 33-0-0 on top chord. The design/selection of such connection device(s) is the responsibility of others.

LOAD CASE(S) Standard

1) Dead + Snow (balanced): Lumber Increase=1.15, Plate Increase=1.15

Uniform Loads (plf)

Vert: A-I=-60, J-P=-20

Concentrated Loads (lb)

Vert: E=-800 Q=-688 R=-679 T=-679 U=-600 V=-600 W=-600 X=-600 Y=-600 Z=-600 AA=-600 AB=-600 AC=-600 AD=-600 AE=-600 AG=-600 AH=-688

WARNING - Verify design parameters and READ NOTES ON THIS AND INCLUDED MITEK REFERENCE PAGE MI-7473 rev. 1/2/2023 BEFORE USE.

Design valid for use only with MiTek® connectors. This design is based only upon parameters shown, and is for an individual building component, not a truss system. Before use, the building designer must verify the applicability of design parameters and properly incorporate this design into the overall building design. Bracing indicated is to prevent buckling of individual truss web and/or chord members only. Additional temporary and permanent bracing is always required for stability and to prevent collapse with possible personal injury and property damage. For general guidance regarding the fabrication, storage, delivery, erection and bracing of trusses and truss systems, see ANSITP11 Quality Criteria, and DSB-22 available from Truss Plate Institute (www.tpinst.org) and BCSI Building Component Safety Information available from the Structural Building Component Association (www.sbcscorponents.com)

MiTek®

18023 Swingley Ridge Rd.
Chesterfield, MO 63017
314.434.1200 / MiTek-US.com