

**LOT 7 - LEVEL 1
FRAMING - 11172025**

27' 0"

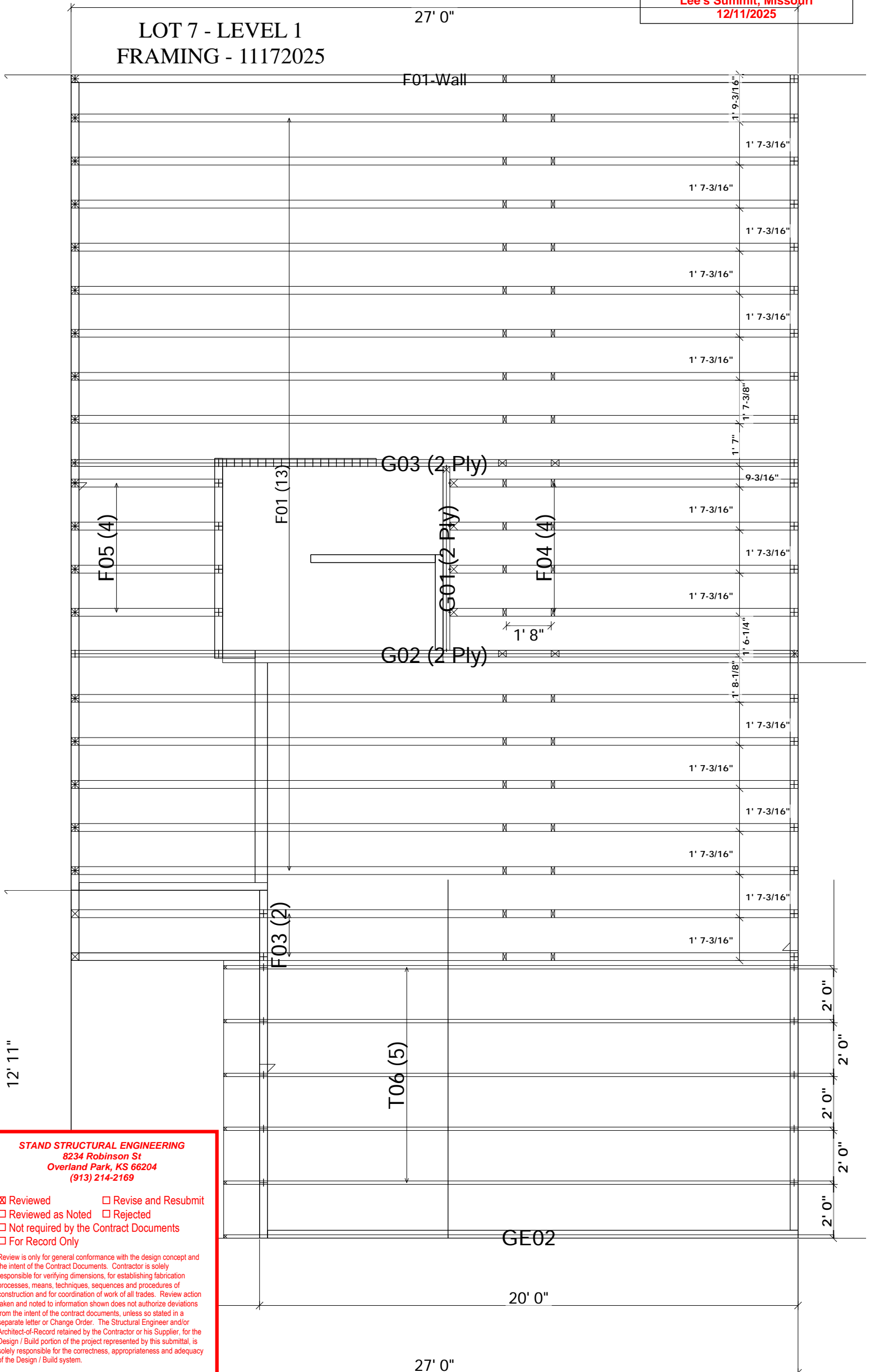

12' 11"

2' 0"
2' 0"
2' 0"
2' 0"

GE02

20' 0"

27' 0"

STAND STRUCTURAL ENGINEERING
8234 Robinson St
Overland Park, KS 66204
(913) 214-2169

- Reviewed
- Revise and Resubmit
- Reviewed as Noted
- Rejected
- Not required by the Contract Documents
- For Record Only

Review is only for general conformance with the design concept and the intent of the Contract Documents. Contractor is solely responsible for verifying dimensions, for establishing fabrication processes, means, techniques, sequences and procedures of construction and for coordination of work of all trades. Review action taken and noted to information shown does not authorize deviations from the intent of the contract documents, unless so stated in a separate letter or Change Order. The Structural Engineer and/or Architect-of-Record retained by the Contractor or his Supplier, for the Design / Build portion of the project represented by this submittal, is solely responsible for the correctness, appropriateness and adequacy of the Design / Build system.

By: JFunk
Date: 12/10/2025

LOT 7 - LEVEL 1
FRAMING - 11172025

27' 0"

GE01

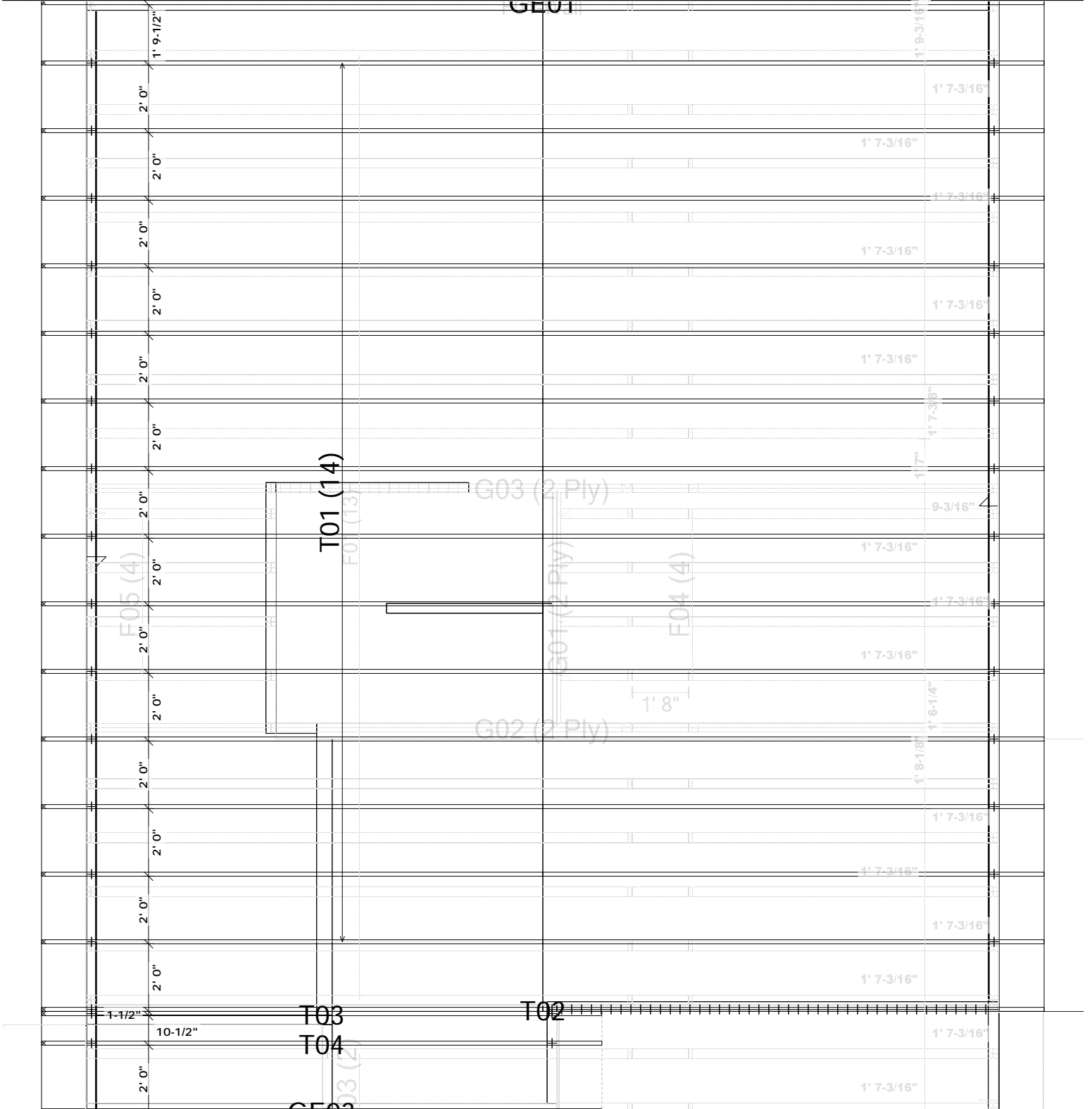

LOT 7 LEVEL 2
FRAMING

13' 11"

27' 0"

GE02

STAND STRUCTURAL ENGINEERING
8234 Robinson St
Overland Park, KS 66204
(913) 214-2169

- Reviewed
- Reviewed as Noted
- Not required by the Contract Documents
- For Record Only
- Revise and Resubmit
- Rejected

Review is only for general conformance with the design concept and the intent of the Contract Documents. Contractor is solely responsible for verifying dimensions, for establishing fabrication processes, means, techniques, sequences and procedures of construction and for coordination of work of all trades. Review action taken and noted to information shown does not authorize deviations from the intent of the contract documents, unless so stated in a separate letter or Change Order. The Structural Engineer and/or Architect-of-Record retained by the Contractor or his Supplier, for the Design / Build portion of the project represented by this submittal, is solely responsible for the correctness, appropriateness and adequacy of the Design / Build system.

By: JFunk
Date: 12/10/2025

**RELEASED FOR
CONSTRUCTION**
As Noted on Plans Review

Development Services Department
Lee's Summit, Missouri
12/11/2025

The truss designs referenced below have been prepared by me or under my direct supervision based on the truss design criteria and requirements ("design criteria") provided by **Quality Line Truss**.

These truss designs are intended for the fabrication of individual building components that will perform to the design criteria provided. Any variance from the design criteria will render the affected truss designs inapplicable.

Listed below are the truss designs included in this package and covered by this seal.

Job: LOT 7_H BUILDING_REF FRAMING_11172025 - 1253550
F01, F01-Wall, F03, F04, F05, G01, G02, G03, GE01, GE02, GE03, T01, T02, T03, T04, T06

Any location identification is for file reference only. No determination of the appropriateness of design criteria for any specific project has been made in preparing the truss designs.

Please refer to individual truss designs for specific design criteria.



**RELEASED FOR
CONSTRUCTION**
As Noted on Plans Review
Development Services Department
Lee's Summit, Missouri
12/11/2025

STAND STRUCTURAL ENGINEERING
8234 Robinson St
Overland Park, KS 66204
(913) 214-2169

Reviewed Revise and Resubmit
 Reviewed as Noted Rejected
 Not required by the Contract Documents
 For Record Only

Review is only for general conformance with the design concept and the intent of the Contract Documents. Contractor is solely responsible for verifying dimensions, for establishing fabrication processes, means, techniques, sequences and procedures of construction and for coordination of work of all trades. Review action taken and noted to information shown does not authorize deviations from the intent of the contract documents, unless so stated in a separate letter or Change Order. The Structural Engineer and/or Architect-of-Record retained by the Contractor or his Supplier, for the Design / Build portion of the project represented by this submittal, is solely responsible for the correctness, appropriateness and adequacy of the Design / Build system.

By: JFunk
Date: 12/10/2025

Arturo A. Hernandez (MO, 2006000095)
My license expiration date for the state of MO is 12/31/2026.

IMPORTANT NOTE: The responsibility of the engineer sealing this package, as a Truss Engineer, is solely for design of individual trusses as individual building components based upon design criteria provided by others and set forth in the referenced truss drawings. The truss design criteria for the components have not been verified as appropriate for any particular building, project or use. Adequacy and suitability of design criteria and requirements for the truss designs for any specific project are the responsibility of the building designer, not the Truss Engineer, per ANSI/TPI-1, Chapter 2.

DESIGN NOTES

- The Truss Design Drawing(s) provided with these Design Notes have been prepared under and are subject to ANSI / TPI 1 published by the Truss Plate Institute, www.tpinst.org. Capitalized terms have the meanings provided in ANSI / TPI 1.
- Copies of each Truss Design Drawing shall be furnished to the installation contractor, Building Designer, Owner and all persons fabricating, handling, installing, bracing, or erecting the trusses.

DESIGN LIMITATIONS

- The Truss Design Drawing is based upon specifications provided by the Building Designer in accordance with ANS1 / TPI 1. Neither the Truss Designer, Eagle, nor an engineer who seals this design (if any) assumes any responsibility for the adequacy or accuracy of specifications provided by the Building Designer.
- The Building Designer is solely responsible for the suitability based upon the Truss Design Drawing and shall be responsible for reviewing and verifying that the information shown is in general conformance with the design of the Building.
- Each Truss Design Drawing is for the individual building component (a truss). A seal on the Truss Design Drawing indicates acceptance of professional engineering responsibility solely for the individual truss.
- Each Truss Design Drawing assumes trusses will be suitably protected from the environment.

HANDLING, INSTALLING, & BRACING

- Refer to Building Component Safety Information (BCSI) for handling, installing, restraining and bracing trusses. Copies can be obtained from the Structural Building Components Association, www.sbcindustry.com.
- Bracing shown on each Truss Design Drawing is for lateral support of individual truss components only to reduce buckling lengths. All temporary and permanent bracing, including lateral load and diagonal or cross bracing, are the responsibility, respectively, of the erector and Building Designer.
- Eagle is not responsible for improper truss fabrication, handling, erection or bracing.
- Compression chords shall be laterally braced by the roof or floor sheathing, directly attached, or have purlins provided at spacing shown, unless noted otherwise.

- Bottom chord required bracing shall be at 10ft spacing or less, if no structural rated ceiling is installed, unless noted otherwise.
- Strongbacking shall be installed on all parallel chord trusses, including flooring systems, to limit deflection and reduce vibration. Refer to BCSI-B7.
- Never exceed the design loading shown. Never stack building or other materials on inadequately braced truss; refer to BCSI.
- Concentration of construction loads greater than the design loads shall not be applied to the trusses at any time; refer to BCSI.
- Trusses shall be handled with care prior to erection to avoid damage. Refer to BCSI for recommended truss handling and erection.

MATERIALS & FABRICATION

- Lumber moisture content shall be 19% or less at the time of fabrication unless noted otherwise.
- Lumber used shall be of the species and size, and in all respects, equal to or better than that specified.
- Unless expressly noted, the truss designs are not applicable for use with fire retardant or preservative treated lumber.
- Plates shall be applied on both faces of truss at each joint and embedded fully. Knots and wane at joint locations shall be regulated in accordance with ANSI / TPI 1.
- For a specified plate gauge and grade, the specified size is a minimum.
- Connections not shown are the responsibility of others.
- Adequate support shall be provided to resist gravity, lateral and uplift loads.
- For 4X2 truss orientation, locate plates 0 - 1/16" from outside the edge of the truss.
- Fabrication of truss shall be in accordance with ANSI / TPI 1.

OTHER NOTES

- Camber is a non-structural consideration and is the responsibility of truss fabricator.
- Do not cut or alter any truss member or plate without prior approval from a professional engineer.
- Lumber design values are in accordance with ANSI / TPI 1; lumber design values are by others.
- Install specified hangers per manufacturer recommendations.

SYMBOLS

PLATE SIZE

3X4 - The first dimension is the width perpendicular to slots. Second dimension is the length parallel to slots.

-, /, |, Indicates required direction of slots; Reference "Joint Details" for more information.

20 Ga Gr40 connectors required

3X10-20HS - 20 Ga Gr60 connectors required

8X10-18HS - 18 Ga Gr60 connectors required

LATERAL BRACING

When this symbol shown, continuous lateral bracing is required on the member of the truss.



BEARING

Indicates location where bearings (supports) occur.



PLATE LOCATION & ORIENTATION

The plate shall be centered on joint and/or placed in accordance with the design drawing/QC full scale details.



REFERENCES

- ANSI / TPI 1:** National Design Standard for Metal Plate Connected Wood Trusses
- BCSI:** Building Component & Safety Information - Guide to Good Practice for Handling, Installing, Restraining, & Bracing of Metal Plate Connected Wood Trusses.
- NDS:** National Design Specification for Wood Construction
- ESR:** 1082 published by the International Code Council. www.icc-es.org

Quality Line Truss Co., LLC

34593 S 4350 RD
Address 2
Adair, OK 74330

Truss:F01-Wall

Job: LOT 7_H BUILDING_REF FRAMING

Date: 12/03/25 20:17:51

Page: 1 of 2

SPAN 27-0-0	PITCH 0/12	QTY 1	OHL 0-0-0	OHR 0-0-0	PLY(S) 1	SPACING 19.19 in	WGT/PLY 140 lbs
----------------	---------------	----------	--------------	--------------	-------------	---------------------	--------------------

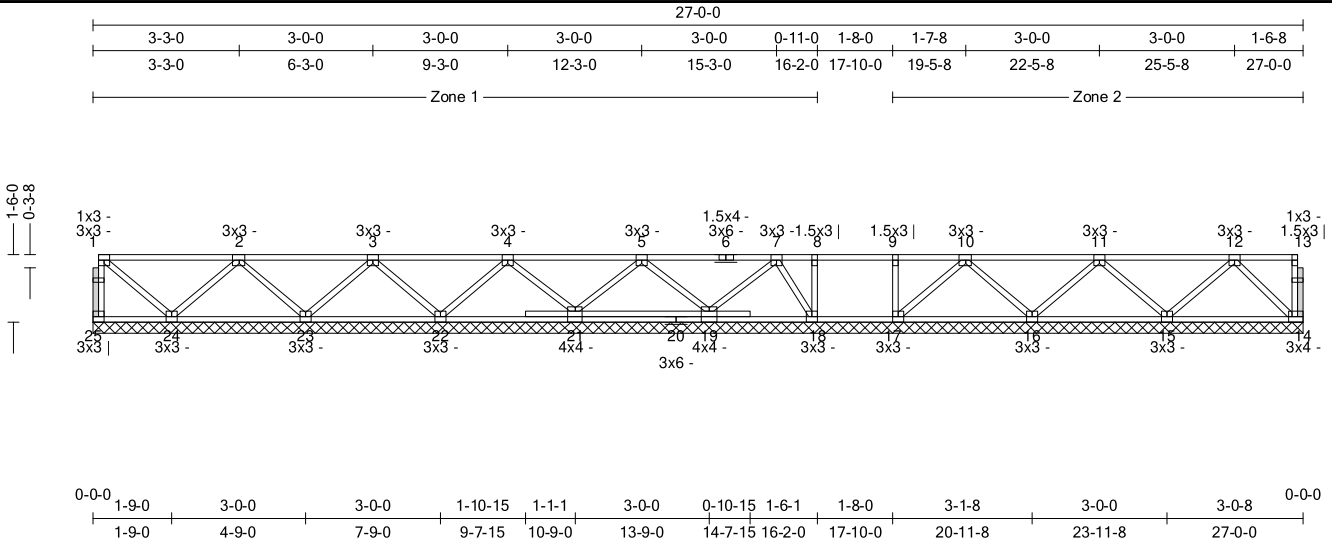

All plates shown to be Eagle 20 unless otherwise noted.

Loading (psf)	General	CSI	Deflection	L/	(loc)	Allowed
TCLL: 40	Bldg Code: IBC 2018/	TC: 0.55 (1-2)	Vert TL: 0.01 in	L/999	(14-15)	L/240
TCDL: 10	TPI 1-2014	BC: 0.08 (15-16)	Vert LL: 0.01 in	L/999	(14-15)	L/360
BCLL: 0	Rep Mbr: No	Web: 0.06 (2-24)	Horz TL: 0 in			
BCDL: 10	Lumber D.O.L.: 100 %					

Reaction

Brg Combo	Brg Width	Rqd Brg Width	Max React	Max Grav Uplift	Max MWFRS Uplift	Max C&C Uplift	Max Uplift	Max Horiz
1	324 in	N/A	308 lbs	-208 lbs
1	324 in	N/A	549 lbs	-75 lbs
1	324 in	N/A	556 lbs	71 lbs
1	324 in	N/A	509 lbs	215 lbs
1	324 in	N/A	439 lbs	-153 lbs
1	324 in	N/A	441 lbs	-136 lbs
1	324 in	N/A	27 lbs
1	324 in	N/A	579 lbs	17 lbs
1	324 in	N/A	574 lbs	20 lbs
1	324 in	N/A	604 lbs	-35 lbs
1	324 in	N/A	394 lbs	284 lbs
1	324 in	N/A	201 lbs

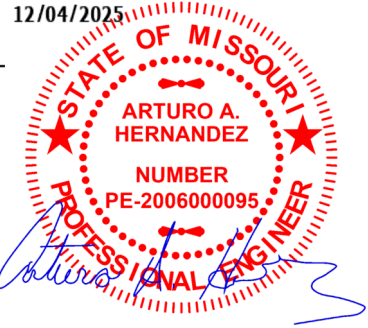

Material

TC: SYP2400/1.8 4 x 2
BC: SYP2400/1.8 4 x 2
Web: SYP#1 4 x 2

Loads

1) Concurrent minimum storage attic loading has been applied in accordance with IBC 1607.1

Load Case L1: Std Live Load

Distributed Loads

Member	Location 1	Location 2	Direction	Spread	Start Load	End Load	Trib Width
Top	0-0-0	27-0-0	Down	Proj	80 plf	80 plf	

Member Forces

Table indicates: Member ID, max CSI, max tension force, (max compression force). Only forces greater than 300lbs are shown in this table.

TC	BC	Web	Member ID	max CSI	max tension force	(max compression force)
		2-24	0.057	(-424 lbs)	5-21	0.051 (-382 lbs)
		2-23	0.054	(-397 lbs)	5-19	0.050 (-376 lbs)
		3-23	0.047	(-350 lbs)	11-16	0.052 (-387 lbs)
		3-22	0.046	(-340 lbs)	11-15	0.051 (-381 lbs)
		4-22	0.050	(-368 lbs)		
		4-21	0.048	(-359 lbs)		

WARNING: Verify all design parameters and follow all notes on this drawing and in the Eagle Metal Design Notes. This design is for an individual building component (a truss), not a truss system, and is based only on parameters shown and provided by the Building Designer. The applicability of the design parameters must be verified by the Building Designer and should properly incorporate this design into the overall building design before use. Bracing shown is only to prevent buckling of individual truss web and/or chord members. Additional temporary and permanent bracing is always required to prevent collapse and provide stability. Design valid only when Eagle Metal connectors are used. A seal on this drawing indicates acceptance of professional engineering responsibility solely for the truss component design shown.

TrueBuild® Truss Software v5.8.14
Eagle Metal Products

Quality Line Truss Co., LLC

34593 S 4350 RD

Address 2

Adair, OK 74330

Truss:F01-Wall

Job: LOT 7_H BUILDING_REF FRAMING

Date: 12/03/25 20:17:52

Page: 2 of 2

SPAN
27-0-0

PITCH
0/12

QTY
1

OHL
0-0-0

OHR
0-0-0

PLY(S)
1

SPACING
19.19 in

WGT/PLY
140lbs

Notes

- 1) Unless noted otherwise, do not cut or alter any truss member or plate without prior approval from a Professional Engineer.
- 2) Unless otherwise specified by the Building Designer, one strongback every 10'-0".
- 3) The fabrication tolerance for this floor truss is 10 % (Cq = 0.90).
- 4) A creep factor of 2.00 has been applied for this truss analysis.
- 5) The "SYP" label shown in the "Material Summary" above indicates the new SPIB design values effective June 1, 2013 were used.
- 6) Indicates non-structural members.

WARNING: Verify all design parameters and follow all notes on this drawing and in the Eagle Metal Design Notes. This design is for an individual building component (a truss), not a truss system, and is based only on parameters shown and provided by the Building Designer. The applicability of the design parameters must be verified by the Building Designer and should properly incorporate this design into the overall building design before use. Bracing shown is only to prevent buckling of individual truss web and/or chord members. Additional temporary and permanent bracing is always required to prevent collapse and provide stability. Design valid only when Eagle Metal connectors are used. A seal on this drawing indicates acceptance of professional engineering responsibility solely for the truss component design shown.

TrueBuild® Truss Software v5.8.14
Eagle Metal Products

Quality Line Truss Co., LLC

34593 S 4350 RD
Address 2
Adair, OK 74330

Truss:F01

Job: LOT 7_H BUILDING_REFRAMING

Date: 12/03/25 20:17:53

Page: 1 of 1

SPAN 27-0-0	PITCH 0/12	QTY 14	OHL 0-0-0	OHR 0-0-0	PLY(S) 1	SPACING 19.19 in	WGT/PLY 145 lbs
----------------	---------------	-----------	--------------	--------------	-------------	---------------------	--------------------

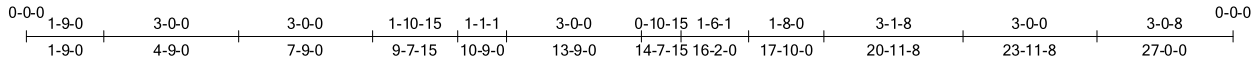
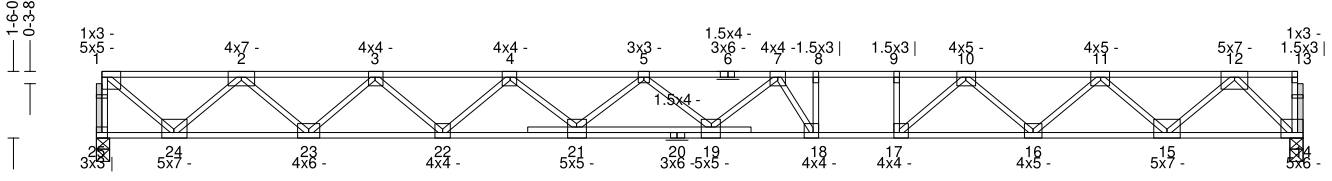
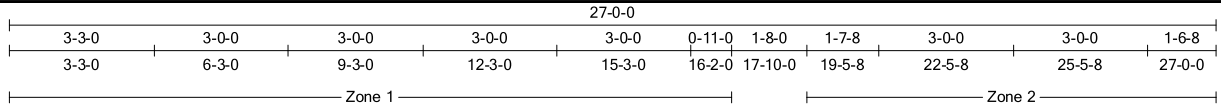

All plates shown to be Eagle 20 unless otherwise noted.

Loading (psf)	General	CSI	Deflection	L/	(loc)	Allowed
TCLL: 40	Bldg Code: IBC 2018/	TC: 0.77 (8-9)	Vert TL: 1.19 in	L/267	(18-19)	L/240
TCDL: 10	TPI 1-2014	BC: 0.97 (18-19)	Vert LL: 0.68 in	L/466	(18-19)	L/360
BCLL: 0	Rep Mbr: Yes	Web: 0.35 (1-24)	Horz TL: 0.16 in		14	
BCDL: 10	Lumber D.O.L.: 100 %					

Reaction

JT	Brg Combo	Brg Width	Rqd Brg Width	Max React	Max Grav Uplift	Max MWFRS Uplift	Max C&C Uplift	Max Uplift	Max Horiz
25	1	3.5 in	1.50 in	1,511 lbs					
14	1	3.5 in	1.50 in	1,511 lbs					

12/04/2025

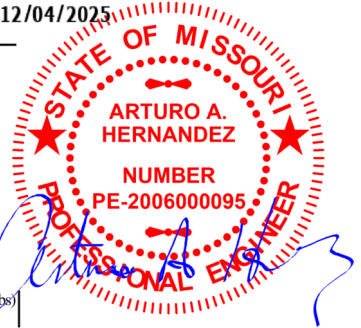

Material

TC: SYP2400/1.8 4 x 2
BC: SYP2400/1.8 4 x 2
Web: SYP#1 4 x 2

Loads

1) Concurrent minimum storage attic loading has been applied in accordance with IBC 1607.1

Member Forces

Table indicates: Member ID, max CSI, max tension force, (max compression force). Only forces greater than 300lbs are shown in this table.

TC	1-2	0.224	(-1,572 lbs)	4-5	0.643	(-7,244 lbs)	8-9	0.770	(-6,710 lbs)	11-12	0.246	(-2,774 lbs)
	2-3	0.365	(-4,112 lbs)	5-7	0.675	(-7,607 lbs)	9-10	0.717	(-6,710 lbs)			
	3-4	0.523	(-5,886 lbs)	7-8	0.738	(-6,710 lbs)	10-11	0.437	(-4,927 lbs)			
BC	14-15	0.189	1,416 lbs	17-18	0.917	6,710 lbs	21-22	0.607	6,686 lbs			
	15-16	0.402	4,001 lbs	18-19	0.965	7,223 lbs	22-23	0.453	5,126 lbs			
	16-17	0.806	5,818 lbs	19-21	0.338	7,564 lbs	23-24	0.289	2,993 lbs			
Web	1-25	0.159	(-1,488 lbs)	4-22	0.131		9-17	0.062	(-511 lbs)	12-14	0.236	(-2,019 lbs)
	1-24	0.347	2,094 lbs	4-21	0.123	744 lbs	10-17	0.225	1,187 lbs			
	2-24	0.234	(-1,928 lbs)	5-21	0.052	(-425 lbs)	10-16	0.147	(-1,210 lbs)			
	2-23	0.252	1,519 lbs	7-19	0.106	555 lbs	11-16	0.208	1,256 lbs			
	3-23	0.167	(-1,376 lbs)	7-18	0.129	(-1,031 lbs)	11-15	0.202	(-1,664 lbs)			
	3-22	0.171	1,030 lbs	8-18	0.097	507 lbs	12-15	0.305	1,842 lbs			

Notes

- 1) Unless noted otherwise, do not cut or alter any truss member or plate without prior approval from a Professional Engineer.
- 2) Unless otherwise specified by the Building Designer, two strongbacks recommended at one third points of the truss span. Strongback spacing or strongback to support should not exceed 10'-0".
- 3) The fabrication tolerance for this floor truss is 10 % (Cq = 0.90).
- 4) A creep factor of 2.00 has been applied for this truss analysis.
- 5) The "SYP" label shown in the "Material Summary" above indicates the new SPIB design values effective June 1, 2013 were used.
- 6) Indicates non-structural members.

WARNING: Verify all design parameters and follow all notes on this drawing and in the Eagle Metal Design Notes. This design is for an individual building component (a truss), not a truss system, and is based only on parameters shown and provided by the Building Designer. The applicability of the design parameters must be verified by the Building Designer and should properly incorporate this design into the overall building design before use. Bracing shown is only to prevent buckling of individual truss web and/or chord members. Additional temporary and permanent bracing is always required to prevent collapse and provide stability. Design valid only when Eagle Metal connectors are used. A seal on this drawing indicates acceptance of professional engineering responsibility solely for the truss component design shown.

TrueBuild® Truss Software v5.8.14
Eagle Metal Products

Quality Line Truss Co., LLC

34593 S 4350 RD
Address 2
Adair, OK 74330

Truss:F03

Job: LOT 7_H BUILDING_REFRAMING

Date: 12/03/25 20:17:56

Page: 1 of 2

SPAN 27-0-0 PITCH 0/12 QTY 1 OHL 0-0-0 OHR 0-0-0 PLY(S) 1 SPACING 19.19 in WGT/PLY 144 lbs

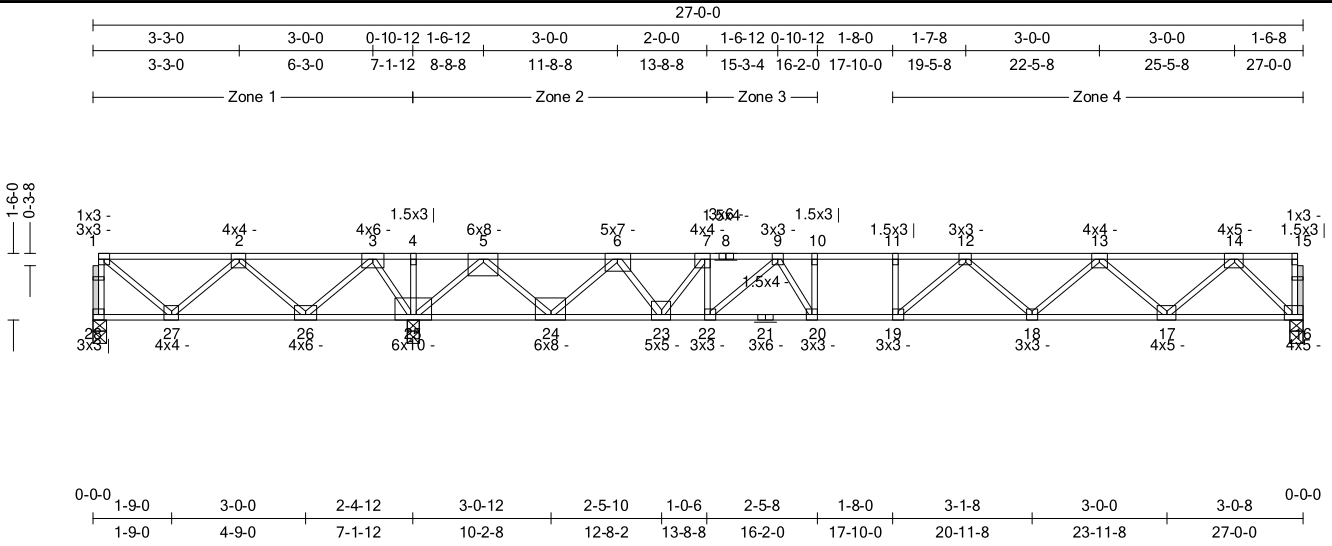

All plates shown to be Eagle 20 unless otherwise noted.

Loading (psf)	General	CSI	Deflection	L/	(loc)	Allowed
TCLL: 40	Bldg Code: IBC 2018/	TC: 0.54 (4-5)	Vert TL: 0.3 in	L/ 781	(18-19)	L/ 240
TCDL: 10	TPI 1-2014	BC: 0.43 (19-20)	Vert LL: 0.16 in	L/ 999	(18-19)	L/ 360
BCLL: 0	Rep Mbr: No	Web: 0.39 (5-24)	Horz TL: 0.05 in		16	
BCDL: 10	Lumber D.O.L.: 100 %					

Reaction

JT	Brg Combo	Brg Width	Rqd Brg Width	Max React	Max Grav Uplift	Max MWFRS Uplift	Max C&C Uplift	Max Uplift	Max Horiz
28	1	3.5 in	1.50 in	41 lbs	-446 lbs	.	.	-446 lbs	.
25	1	3.5 in	1.50 in	3,049 lbs
16	1	3.5 in	1.50 in	1,073 lbs



Material

TC: SYP2400/1.8 4 x 2
BC: SYP2400/1.8 4 x 2
Web: SYP#1 4 x 2

Loads

1) Concurrent minimum storage attic loading has been applied in accordance with IBC 1607.1

Load Case L1: Std Live Load

Point Loads	Member	Location	Direction	Load	Trib Width
	Top	13-8-8	Down	353 lbs	

Load Case D1: Std Dead Load

Point Loads	Member	Location	Direction	Load	Trib Width
	Top	13-8-8	Down	353 lbs	

Member Forces

Table indicates: Member ID, max CSI, max tension force, (max compression force). Only forces greater than 300lbs are shown in this table.

TC	1-2	0.347	582 lbs	6-7	0.201	(-2,194 lbs)	11-12	0.320	(-3,612 lbs)
	2-3	0.493	2,200 lbs	7-9	0.279	(-3,086 lbs)	12-13	0.303	(-3,103 lbs)
	3-4	0.514	3,991 lbs	9-10	0.322	(-3,612 lbs)	13-14	0.207	(-1,858 lbs)
	4-5	0.539	3,991 lbs	10-11	0.330	(-3,612 lbs)			
BC	16-17	0.152	985 lbs	19-20	0.431	3,612 lbs	23-24	0.176	1,315 lbs
	17-18	0.294	2,620 lbs	20-22	0.404	3,448 lbs	24-25	0.201	(-1,988 lbs)
	18-19	0.396	3,471 lbs	22-23	0.298	3,086 lbs	25-26	0.309	(-3,251 lbs)
Web	1-28	0.087	454 lbs	5-25	0.328	(-2,668 lbs)	9-22	0.066	(-488 lbs)
	1-27	0.101	(-775 lbs)	5-24	0.395	2,306 lbs	9-20	0.098	513 lbs
	2-27	0.151	886 lbs	6-24	0.272	(-2,174 lbs)	10-20	0.038	(-314 lbs)
	2-26	0.164	(-1,308 lbs)	6-23	0.265	1,527 lbs	12-19	0.065	341 lbs
	3-26	0.242	1,427 lbs	7-23	0.175	(-1,487 lbs)	12-18	0.065	(-498 lbs)
	3-25	0.154	(-1,354 lbs)	7-22	0.061	353 lbs	13-18	0.109	655 lbs
							26-27	0.125	(-1,235 lbs)

WARNING: Verify all design parameters and follow all notes on this drawing and in the Eagle Metal Design Notes. This design is for an individual building component (a truss), not a truss system, and is based only on parameters shown and provided by the Building Designer. The applicability of the design parameters must be verified by the Building Designer and should properly incorporate this design into the overall building design before use. Bracing shown is only to prevent buckling of individual truss web and/or chord members. Additional temporary and permanent bracing is always required to prevent collapse and provide stability. Design valid only when Eagle Metal connectors are used. A seal on this drawing indicates acceptance of professional engineering responsibility solely for the truss component design shown.

TrueBuild® Truss Software v5.8.14
Eagle Metal Products

Quality Line Truss Co., LLC

34593 S 4350 RD

Address 2

Adair, OK 74330

Truss:F03

Job: LOT 7_H BUILDING_REF FRAMING

Date: 12/03/25 20:17:56

Page: 2 of 2

SPAN
27-0-0

PITCH
0/12

QTY
1

OHL
0-0-0

OHR
0-0-0

PLY(S)
1

SPACING
19.19 in

WGT/PLY
144 lbs

Notes

- 1) Unless noted otherwise, do not cut or alter any truss member or plate without prior approval from a Professional Engineer.
- 2) Unless otherwise specified by the Building Designer, one strongback every 10'-0".
- 3) The fabrication tolerance for this floor truss is 10 % (Cq = 0.90).
- 4) A creep factor of 2.00 has been applied for this truss analysis.
- 5) The "SYP" label shown in the "Material Summary" above indicates the new SPIB design values effective June 1, 2013 were used.
- 6) Indicates non-structural members.
- 7) Due to negative reactions in gravity load cases, special connections to the bearing surface at joint 28 may need to be considered.

WARNING: Verify all design parameters and follow all notes on this drawing and in the Eagle Metal Design Notes. This design is for an individual building component (a truss), not a truss system, and is based only on parameters shown and provided by the Building Designer. The applicability of the design parameters must be verified by the Building Designer and should properly incorporate this design into the overall building design before use. Bracing shown is only to prevent buckling of individual truss web and/or chord members. Additional temporary and permanent bracing is always required to prevent collapse and provide stability. Design valid only when Eagle Metal connectors are used. A seal on this drawing indicates acceptance of professional engineering responsibility solely for the truss component design shown.

TrueBuild® Truss Software v5.8.14
Eagle Metal Products

Quality Line Truss Co., LLC

34593 S 4350 RD
Address 2
Adair, OK 74330

Truss:F04

Job: LOT 7_H BUILDING_REFRAMING

Date: 12/03/25 20:18:10

Page: 1 of 1

SPAN
12-11-4

PITCH
0/12

QTY
4

OHL
0-0-0

OHR
0-0-0

PLY(S)
1

SPACING
19.19 in

WGT/PLY
68 lbs

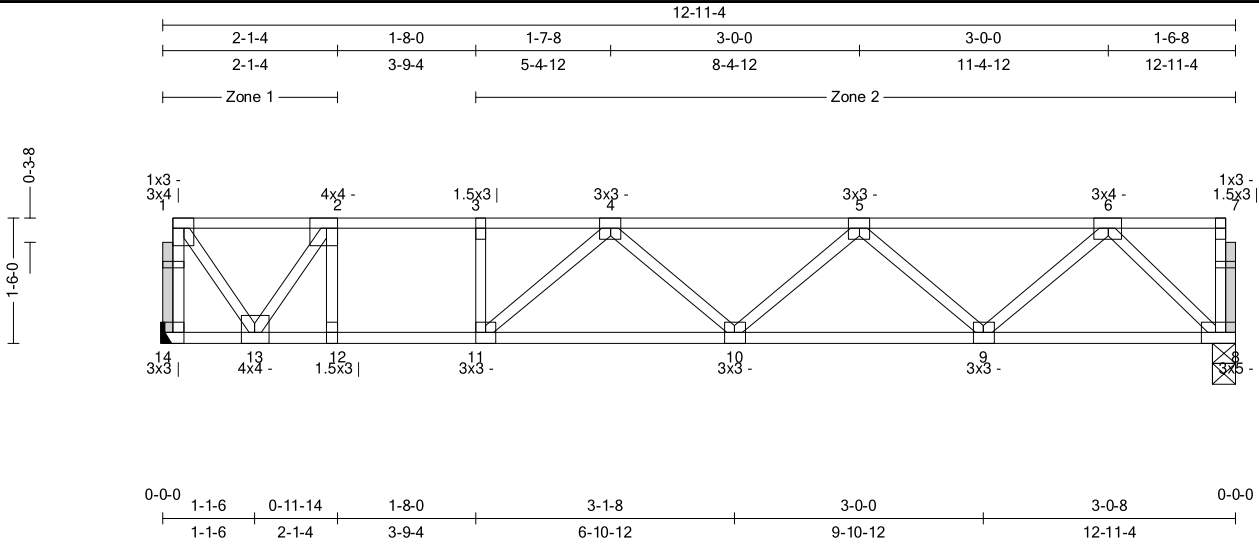

All plates shown to be Eagle 20 unless otherwise noted.

Loading (psf)	General	CSI	Deflection	L/	(loc)	Allowed
TCLL: 40	Bldg Code: IBC 2018/	TC: 0.42 (1-2)	Vert TL: 0.3 in	L/499	(10-11)	L/240
TCDL: 10	TPI 1-2014	BC: 0.65 (11-12)	Vert LL: 0.17 in	L/880	(10-11)	L/360
BCLL: 0	Rep Mbr: Yes	Web: 0.14 (1-13)	Horz TL: 0.02 in		8	
BCDL: 10	Lumber D.O.L.: 100 %					

Reaction

JT	Brg Combo	Brg Width	Rqd Brg Width	Max React	Max Grav Uplift	Max MWFRS Uplift	Max C&C Uplift	Max Uplift	Max Horiz
14	1	1.5 in	---	724 lbs					
8	1	3.5 in	1.50 in	724 lbs					

Material

TC: SYP2400/1.8 4 x 2
BC: SYP2400/1.8 4 x 2
Web: SYP#1 4 x 2

Loads

1) Concurrent minimum storage attic loading has been applied in accordance with IBC 1607.1

Member Forces

Table indicates: Member ID, max CSI, max tension force, (max compression force). Only forces greater than 300lbs are shown in this table.

TC	1-2	0.425	(-461 lbs)	3-4	0.389	(-1,118 lbs)	5-6	0.153	(-1,125 lbs)
	2-3	0.412	(-1,118 lbs)	4-5	0.182	(-1,643 lbs)			
BC	8-9	0.116	641 lbs	10-11	0.483	1,581 lbs	12-13	0.654	1,118 lbs
	9-10	0.273	1,517 lbs	11-12	0.654	1,118 lbs			
Web	1-14	0.070	(-659 lbs)	2-12	0.085	511 lbs	6-9	0.109	656 lbs
	1-13	0.137	826 lbs	4-11	0.076	(-617 lbs)	6-8	0.107	(-914 lbs)
	2-13	0.130	(-1,176 lbs)	5-9	0.065	(-532 lbs)			

Notes

- 1) Unless noted otherwise, do not cut or alter any truss member or plate without prior approval from a Professional Engineer.
- 2) Unless otherwise specified by the Building Designer, one strongback every 10'-0".
- 3) The fabrication tolerance for this floor truss is 10% (Cq = 0.90).
- 4) Hanger is for graphical interpretation only. Install hanger per manufacturer's recommendation.
- 5) A creep factor of 2.00 has been applied for this truss analysis.
- 6) The "SYP" label shown in the "Material Summary" above indicates the new SPIB design values effective June 1, 2013 were used.
- 7) Indicates non-structural members.



WARNING: Verify all design parameters and follow all notes on this drawing and in the Eagle Metal Design Notes. This design is for an individual building component (a truss), not a truss system, and is based only on parameters shown and provided by the Building Designer. The applicability of the design parameters must be verified by the Building Designer and should properly incorporate this design into the overall building design before use. Bracing shown is only to prevent buckling of individual truss web and/or chord members. Additional temporary and permanent bracing is always required to prevent collapse and provide stability. Design valid only when Eagle Metal connectors are used. A seal on this drawing indicates acceptance of professional engineering responsibility solely for the truss component design shown.

TrueBuild® Truss Software v5.8.14
Eagle Metal Products

Quality Line Truss Co., LLC

34593 S 4350 RD
Address 2
Adair, OK 74330

Truss:F05

Job: LOT 7_H BUILDING_REF FRAMING

Date: 12/03/25 20:17:57

Page: 1 of 1

SPAN
5-7-8

PITCH
0/12

QTY
4

OHL
0-0-0

OHR
0-0-0

PLY(S)
1

SPACING
19.19 in

WGT/PLY
32 lbs

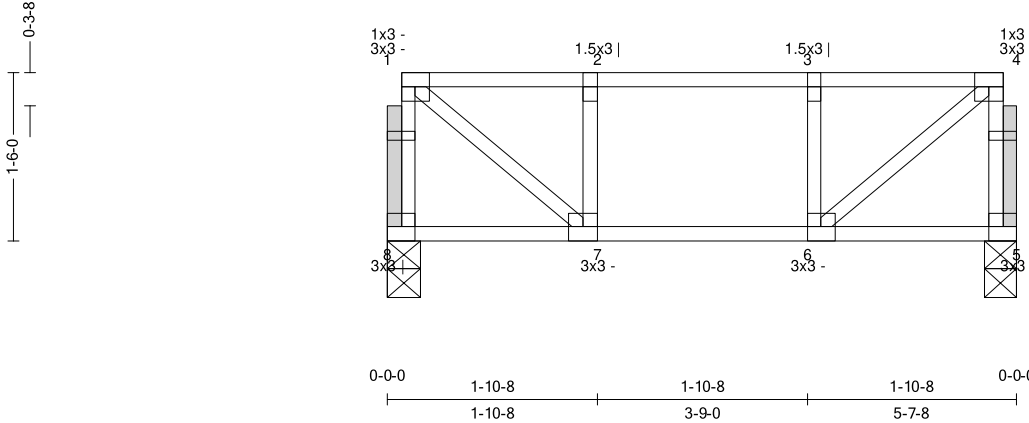

All plates shown to be Eagle 20 unless otherwise noted.

Loading (psf)	General	CSI	Deflection	L/	(loc)	Allowed
TCLL: 40	Bldg Code: IBC 2018/	TC: 0.10 (1-2)	Vert TL: 0.01 in	L/999	(5-6)	L/240
TCDL: 10	TPI 1-2014	BC: 0.11 (6-7)	Vert LL: 0.01 in	L/999	(5-6)	L/360
BCLL: 0	Rep Mbr: Yes	Web: 0.06 (1-7)	Horz TL: 0 in		5	
BCDL: 10	Lumber D.O.L.: 100 %					

Reaction

12/04/2025

JT	Brg Combo	Brg Width	Rqd Brg Width	Max React	Max Grav Uplift	Max MWFRS Uplift	Max C&C Uplift	Max Uplift	Max Horiz
8	1	3.5 in	1.50 in	315 lbs					
5	1	3.5 in	1.50 in	315 lbs					

Material

TC: SYP#1 4 x 2
BC: SYP#1 4 x 2
Web: SYP#1 4 x 2

Loads

1) Concurrent minimum storage attic loading has been applied in accordance with IBC 1607.1

Member Forces

Table indicates: Member ID, max CSI, max tension force, (max compression force). Only forces greater than 300lbs are shown in this table.

TC	BC	Web	1-7	0.059	357 lbs
		4-6	0.059	357 lbs	

Notes

- 1) Unless noted otherwise, do not cut or alter any truss member or plate without prior approval from a Professional Engineer.
- 2) The fabrication tolerance for this floor truss is 10 % (Cq = 0.90).
- 3) A creep factor of 2.00 has been applied for this truss analysis.
- 4) The "SYP" label shown in the "Material Summary" above indicates the new SPIB design values effective June 1, 2013 were used.
- 5) Indicates non-structural members.

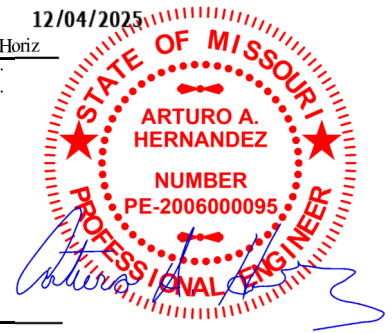

WARNING: Verify all design parameters and follow all notes on this drawing and in the Eagle Metal Design Notes. This design is for an individual building component (a truss), not a truss system, and is based only on parameters shown and provided by the Building Designer. The applicability of the design parameters must be verified by the Building Designer and should properly incorporate this design into the overall building design before use. Bracing shown is only to prevent buckling of individual truss web and/or chord members. Additional temporary and permanent bracing is always required to prevent collapse and provide stability. Design valid only when Eagle Metal connectors are used. A seal on this drawing indicates acceptance of professional engineering responsibility solely for the truss component design shown.

TrueBuild® Truss Software v5.8.14
Eagle Metal Products

Quality Line Truss Co., LLC

34593 S 4350 RD
Address 2
Adair, OK 74330

Truss:G01

Job: LOT 7_H BUILDING_REFRAMING

Date: 12/03/25 20:18:11

Page: 1 of 2

SPAN 6-10-0	PITCH 0/12	QTY 1	OHL 0-0-0	OHR 0-0-0	CANT L 0-0-0	CANT R 0-0-0	PLY(S) 2	SPACING 1.5 in	WGT/PLY 32 lbs
----------------	---------------	----------	--------------	--------------	-----------------	-----------------	-------------	-------------------	-------------------

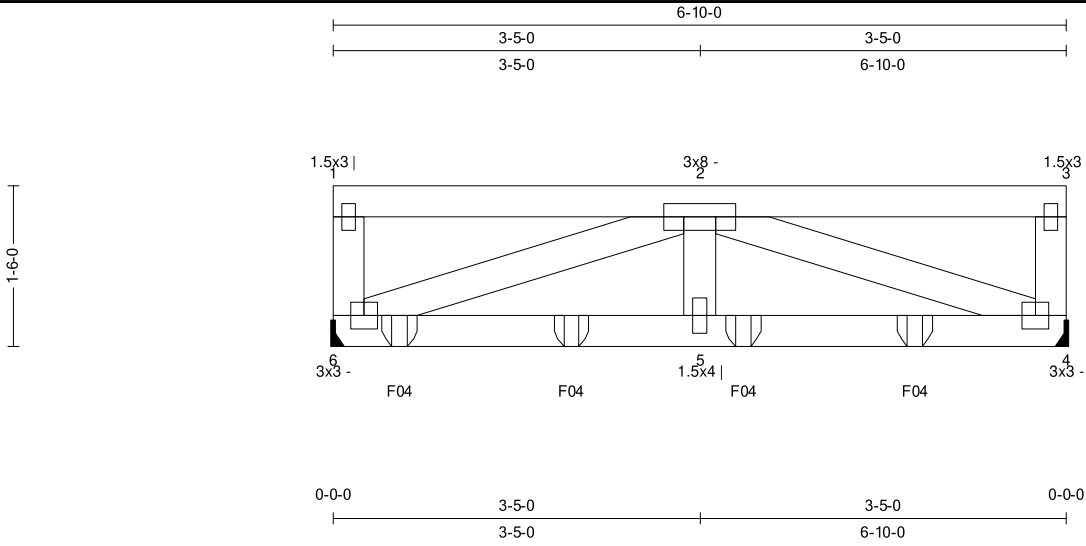

All plates shown to be Eagle 20 unless otherwise noted.

Loading (psf)	General	CSI	Deflection	L/	(loc)	Allowed
Carried Loads (psf)	Bldg Code: IBC 2018/	TC: 0.08 (2-3)	Vert TL: 0.05 in	L/999	(4-5)	L/240
TCLL: 40	TPI 1-2014	BC: 0.65 (4-5)	Vert LL: 0.03 in	L/999	(4-5)	L/360
TCDL: 10	Rep Mbr: No	Web: 0.12 (2-5)	Horz TL: 0.01 in		4	
BCLL: 0	Lumber D.O.L.: 115 %					
BCDL: 10						

12/04/2025

Reaction

JT	Brg Combo	Brg Width	Rqd Brg Width	Max React	Max Grav Uplift	Max MWFRS Uplift	Max C&C Uplift	Max Uplift	Max Horiz
6	1	1.5 in	---	1,462 lbs					-3 lbs
4	1	1.5 in	---	1,071 lbs					

Material

TC: SYP#1 2 x 4
BC: SYP#1 2 x 4
Web: SYP#1 2 x 4

Bracing

TC: Sheathed or Purlins at 6-3-0, Purlin design by Others.
BC: Sheathed or Purlins at 10-0-0, Purlin design by Others.



Loads

- 1) This truss has been designed for the effects of balanced (20 psf) sloped roof snow loads in accordance with ASCE7 - 16 with the following user defined input: 20 psf GSL, Terrain C, Exposure (Ce = 1.0), Thermal (Ct = 1.00), DOL = 1.15. If the roof configuration differs from hip/gable, Building Designer shall verify snow loads.
- 2) This truss has not been designed for the effects of unbalanced snow loads.
- 3) This truss has been designed for the effects of wind loads in accordance with ASCE7 - 16 with the following user defined input: 115 mph (Factored), Exposure C, Enclosed, Gable/Hip, Risk Category II, Overall Bldg Dims 25 ft x 60 ft, h = 15 ft, End Zone Truss, Both end webs considered. DOL = 1.60
- 4) Concurrent minimum storage attic loading has been applied in accordance with IBC 1607.1

Load Case Lr1: Std Live Load

Distributed Loads

Member	Location 1	Location 2	Direction	Spread	Start Load	End Load	Trib Width
Top	0-0-0	6-10-0	Down	Proj	5 plf	5 plf	

Load Case D1: Std Dead Load

Distributed Loads

Member	Location 1	Location 2	Direction	Spread	Start Load	End Load	Trib Width
Top	0-0-0	6-10-0	Down	Proj	1.25 plf	1.25 plf	
Bot	0-0-0	6-10-0	Down	Proj	1.25 plf	1.25 plf	

Member Forces

Table indicates: Member ID, max CSI, max tension force, (max compression force). Only forces greater than 300lbs are shown in this table.

TC	BC	Web
4-5	0.649	945 lbs
5-6	0.589	945 lbs
2-6	0.112	(-1,007 lbs)
2-5	0.118	710 lbs

Truss to Truss Connection Summary

Carried Truss	Carrying Chord	Carrying Offset
F04	BC	0-7-7
F04	BC	2-2-10
F04	BC	3-9-13
F04	BC	5-5-0

WARNING: Verify all design parameters and follow all notes on this drawing and in the Eagle Metal Design Notes. This design is for an individual building component (a truss), not a truss system, and is based only on parameters shown and provided by the Building Designer. The applicability of the design parameters must be verified by the Building Designer and should properly incorporate this design into the overall building design before use. Bracing shown is only to prevent buckling of individual truss web and/or chord members. Additional temporary and permanent bracing is always required to prevent collapse and provide stability. Design valid only when Eagle Metal connectors are used. A seal on this drawing indicates acceptance of professional engineering responsibility solely for the truss component design shown.

TrueBuild® Truss Software v5.8.14
Eagle Metal Products

Quality Line Truss Co., LLC

34593 S 4350 RD

Address 2

Adair, OK 74330

Truss:G01

Job: LOT 7_H BUILDING_REF FRAMING

Date: 12/03/25 20:18:12

Page: 2 of 2

SPAN
6-10-0PITCH
0/12QTY
1OHL
0-0-0OHR
0-0-0CANT L
0-0-0CANT R
0-0-0PLY(S)
2SPACING
1.5 inWGT/PLY
32 lbs**Notes**

- 1) Unless noted otherwise, do not cut or alter any truss member or plate without prior approval from a Professional Engineer.
- 2) The fabrication tolerance for this roof truss is 20 % (Cq = 0.80).
- 3) Hangers are for graphical interpretation only. Install hangers per manufacturer's recommendations.
- 4) Provide adequate drainage to prevent ponding.
- 5) Brace bottom chord with approved sheathing or purlins per Bracing Summary.
- 6) A creep factor of 2.00 has been applied for this truss analysis.
- 7) The "SYP" label shown in the "Material Summary" above indicates the new SP1B design values effective June 1, 2013 were used.
- 8) The forces shown for this multi-ply truss are per ply and the reactions are for all plies. Two identical trusses shall be built and attached as follows, per ply: 10d Nails or Gun Nails [min 0.120"x2.875"] TC - 1 row @ 1-0-0 oc, BC - 1 row @ 1-0-0 oc, Webs - 1 row @ 1-0-0 oc.

Provided the hanger connections do not adequately transfer the applied load to all plies: in addition to connectors shown above, attach each pair of girder plies with supplemental 10d Nails or Gun Nails [min 0.120"x2.875"] as follows within 24" of the location shown:

- BC: 0-7-7,(5)Connectors
- BC: 2-2-10,(5)Connectors
- BC: 3-9-13,(5)Connectors
- BC: 5-5-0,(5)Connectors

Connectors shall not encroach on other girder ply connectors or truss-to-truss connectors in accordance with the NDS or the connector manufacturer recommendations.

- 9) When applied loads are on one side of girder, do not flip girder during girder connector installation, install connectors on the girder side where supported loads are applied. When applied loads are on both sides of girder, double the spacing and install half of the connectors on one side of girder and then flip the girder to install the other half of the connectors on the opposite side (at double the connector spacing). Connectors on opposite sides of the girder shall be offset.
- 10) Lateral bracing shall be attached to each ply.
- 11) All fasteners minimum 2-1/2" long, unless otherwise noted.
- 12) Nails in 1st and 2nd ply shall be offset from successive plies by 1/2 the nail spacing.
- 13) Listed wind uplift reactions based on MWFRS & C&C loading.

WARNING: Verify all design parameters and follow all notes on this drawing and in the Eagle Metal Design Notes. This design is for an individual building component (a truss), not a truss system, and is based only on parameters shown and provided by the Building Designer. The applicability of the design parameters must be verified by the Building Designer and should properly incorporate this design into the overall building design before use. Bracing shown is only to prevent buckling of individual truss web and/or chord members. Additional temporary and permanent bracing is always required to prevent collapse and provide stability. Design valid only when Eagle Metal connectors are used. A seal on this drawing indicates acceptance of professional engineering responsibility solely for the truss component design shown.

TrueBuild@Truss Software v5.8.14
Eagle Metal Products

1253550 0011/0024

Quality Line Truss Co., LLC

34593 S 4350 RD
Address 2
Adair, OK 74330

Truss:G02
Job: LOT 7_H BUILDING_REFRAMING
Date: 12/03/25 20:18:14
Page: 1 of 2

SPAN 27-0-0	PITCH 0/12	QTY 1	OHL 0-0-0	OHR 0-0-0	CANT L 0-0-0	CANT R 0-0-0	PLY(S) 2	SPACING 18.47 in	WGT/PLY 126 lbs
----------------	---------------	----------	--------------	--------------	-----------------	-----------------	-------------	---------------------	--------------------

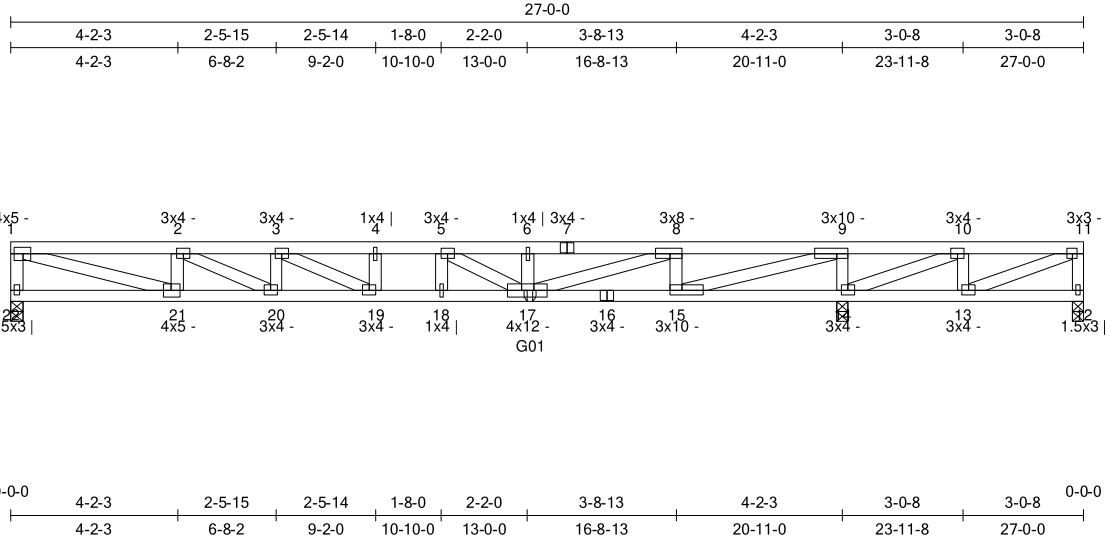

All plates shown to be Eagle 20 unless otherwise noted.

Loading (psf)	General	CSI	Deflection	L/	(loc)	Allowed
Carried Loads (psf)	Bldg Code: IBC 2018/	TC: 0.40 (9-10)	Vert TL: 0.31 in	L/ 791	(17-18)	L/ 240
TCLL: 40	TPI 1-2014	BC: 0.30 (17-18)	Vert LL: 0.11 in	L/ 999	19	L/ 360
TCDL: 10	Rep Mbr: No	Web: 0.48 (9-15)	Horz TL: 0.01 in		14	
BCLL: 0	Lumber D.O.L.: 115 %					
BCDL: 10						

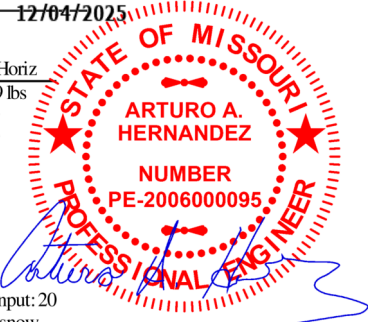

Reaction

JT	Brg Combo	Brg Width	Rqd Brg Width	Max React	Max Grav Uplift	Max MWFRS Uplift	Max C&C Uplift	Max Uplift	Max Horiz
22	1	3.5 in	1.50 in	1,091 lbs			-140 lbs	-140 lbs	39 lbs
14	1	3.5 in	1.50 in	3,202 lbs			-188 lbs	-188 lbs	
12	1	3.5 in	N/A	0 lbs	-728 lbs	-103 lbs	-33 lbs	-728 lbs	

Material

TC: SYP2400/1.8 2 x 4
BC: SYP2400/1.8 2 x 4
Web: SYP#1 2 x 4

Bracing

TC: Sheathed or Purlins at 6-3-0, Purlin design by Others.
BC: Sheathed or Purlins at 9-8-0, Purlin design by Others.

Loads

- This truss has been designed for the effects of balanced (20 psf) sloped roof snow loads in accordance with ASCE7 - 16 with the following user defined input: 20 psf GSL, Terrain C, Exposure (Ce = 1.0), Thermal (Ct = 1.00), DOL = 1.15. If the roof configuration differs from hip/gable, Building Designer shall verify snow loads.
- This truss has not been designed for the effects of unbalanced snow loads.
- This truss has been designed for the effects of wind loads in accordance with ASCE7 - 16 with the following user defined input: 115 mph (Factored), Exposure C, Enclosed, Gable/Hip, Risk Category II, Overall Bldg Dims 25 ft x 60 ft, h = 15 ft, End Zone Truss, Both end webs considered. DOL = 1.60
- Concurrent minimum storage attic loading has been applied in accordance with IBC 1607.1

Load Case Lr1: Std Live Load

Distributed Loads

Member	Location 1	Location 2	Direction	Spread	Start Load	End Load	Trib Width
Top	0-0-0	12-11-4	Down	Proj	30.78 plf	30.78 plf	
Top	12-11-4	27-0-0	Down	Proj	30.78 plf	30.78 plf	
Top	0-0-0	27-0-0	Down	Proj	30.78 plf	30.78 plf	

Load Case D1: Std Dead Load

Distributed Loads

Member	Location 1	Location 2	Direction	Spread	Start Load	End Load	Trib Width
Top	0-0-0	12-11-4	Down	Proj	7.7 plf	7.7 plf	
Top	12-11-4	27-0-0	Down	Proj	7.7 plf	7.7 plf	
Top	0-0-0	27-0-0	Down	Proj	7.7 plf	7.7 plf	
Bot	0-0-0	12-11-4	Down	Proj	7.7 plf	7.7 plf	
Bot	12-11-4	27-0-0	Down	Proj	7.7 plf	7.7 plf	
Bot	0-0-0	27-0-0	Down	Proj	7.7 plf	7.7 plf	

Member Forces

Table indicates: Member ID, max CSI, max tension force, (max compression force). Only forces greater than 300lbs are shown in this table.

TC	1-2	0.132	(-1,485 lbs)	4-5	0.210	(-2,484 lbs)	8-9	0.155	(-483 lbs)
	2-3	0.175	(-2,059 lbs)	5-6	0.213	(-2,514 lbs)	9-10	0.397	2,290 lbs
	3-4	0.211	(-2,484 lbs)	6-8	0.218	(-2,514 lbs)	10-11	0.129	1,030 lbs

WARNING: Verify all design parameters and follow all notes on this drawing and in the Eagle Metal Design Notes. This design is for an individual building component (a truss), not a truss system, and is based only on parameters shown and provided by the Building Designer. The applicability of the design parameters must be verified by the Building Designer and should properly incorporate this design into the overall building design before use. Bracing shown is only to prevent buckling of individual truss web and/or chord members. Additional temporary and permanent bracing is always required to prevent collapse and provide stability. Design valid only when Eagle Metal connectors are used. A seal on this drawing indicates acceptance of professional engineering responsibility solely for the truss component design shown.

TrueBuild® Truss Software v5.8.14
Eagle Metal Products

Quality Line Truss Co., LLC

34593 S 4350 RD
Address 2
Adair, OK 74330

Truss:G02

Job: LOT 7_H BUILDING_REF FRAMING

Date: 12/03/25 20:18:14

Page: 2 of 2

SPAN	PITCH	QTY	OHL	OHR	CANT L	CANT R	PLY(S)	SPACING	WGT/PLY
27-0-0	0/12	1	0-0-0	0-0-0	0-0-0	0-0-0	2	18.47 in	126 lbs
BC	13-14 0.126 14-15 0.200 15-17 0.114	(-1,030 lbs) (-2,290 lbs) 483 lbs	17-18 0.301 2,484 lbs 18-19 0.301 2,484 lbs 19-20 0.216 2,059 lbs	20-21 0.172 1,485 lbs					
Web	1-22 0.053 1-21 0.257 1,551 lbs 2-21 0.043 2-20 0.106 638 lbs 3-19 0.078 473 lbs	(-523 lbs) (-424 lbs)	8-17 0.354 2,134 lbs 8-15 0.080 (-794 lbs) 9-15 0.478 2,887 lbs 9-14 0.102 (-1,006 lbs) 10-14 0.148 (-1,355 lbs)	10-13 0.069 416 lbs 11-13 0.121 (-1,116 lbs) 11-12 0.062 377 lbs					

Truss to Truss Connection Summary

Carried Truss	Carrying Chord	Carrying Offset
G01	BC	13-0-12

Notes

- 1) Unless noted otherwise, do not cut or alter any truss member or plate without prior approval from a Professional Engineer.
- 2) The fabrication tolerance for this roof truss is 20 % (Cq = 0.80).
- 3) Provide adequate drainage to prevent ponding.
- 4) Brace bottom chord with approved sheathing or purlins per Bracing Summary.
- 5) A creep factor of 2.00 has been applied for this truss analysis.
- 6) The "SYP" label shown in the "Material Summary" above indicates the new SPIB design values effective June 1, 2013 were used.
- 7) Due to negative reactions in gravity load cases, special connections to the bearing surface at joint 12 may need to be considered.
- 8) The forces shown for this multi-ply truss are per ply and the reactions are for all plies. Two identical trusses shall be built and attached as follows, per ply: 10d Nails or Gun Nails [min 0.120"x2.875"] TC - 1 row @ 1-0-0 oc, BC - 1 row @ 1-0-0 oc, Webs - 1 row @ 1-0-0 oc.

Provided the hanger connections do not adequately transfer the applied load to all plies: in addition to connectors shown above, attach each pair of girder plies with supplemental 10d Nails or Gun Nails [min 0.120"x2.875"] as follows within 24" of the location shown:

BC: 13-0-12,(8)Connectors

Connectors shall not encroach on other girder ply connectors or truss-to-truss connectors in accordance with the NDS or the connector manufacturer recommendations.

9) When applied loads are on one side of girder, do not flip girder during girder connector installation, install connectors on the girder side where supported loads are applied. When applied loads are on both sides of girder, double the spacing and install half of the connectors on one side of girder and then flip the girder to install the other half of the connectors on the opposite side (at double the connector spacing). Connectors on opposite sides of the girder shall be offset.

10) Lateral bracing shall be attached to each ply.

11) All fasteners minimum 2-1/2" long, unless otherwise noted.

12) Nails in 1st and 2nd ply shall be offset from successive plies by 1/2 the nail spacing.

13) Listed wind uplift reactions based on MWFRS & C&C loading.

WARNING: Verify all design parameters and follow all notes on this drawing and in the Eagle Metal Design Notes. This design is for an individual building component (a truss), not a truss system, and is based only on parameters shown and provided by the Building Designer. The applicability of the design parameters must be verified by the Building Designer and should properly incorporate this design into the overall building design before use. Bracing shown is only to prevent buckling of individual truss web and/or chord members. Additional temporary and permanent bracing is always required to prevent collapse and provide stability. Design valid only when Eagle Metal connectors are used. A seal on this drawing indicates acceptance of professional engineering responsibility solely for the truss component design shown.

TrueBuild® Truss Software v5.8.14
Eagle Metal Products

Quality Line Truss Co., LLC

34593 S 4350 RD

Address 2

Adair, OK 74330

Truss:G03

Job: LOT 7_H BUILDING_REFRAMING

Date: 12/03/25 20:18:16

Page: 1 of 2

SPAN 27-0-0	PITCH 0/12	QTY 1	OHL 0-0-0	OHR 0-0-0	CANT L 0-0-0	CANT R 0-0-0	PLY(S) 2	SPACING 30 in	WGT/PLY 125 lbs
----------------	---------------	----------	--------------	--------------	-----------------	-----------------	-------------	------------------	--------------------

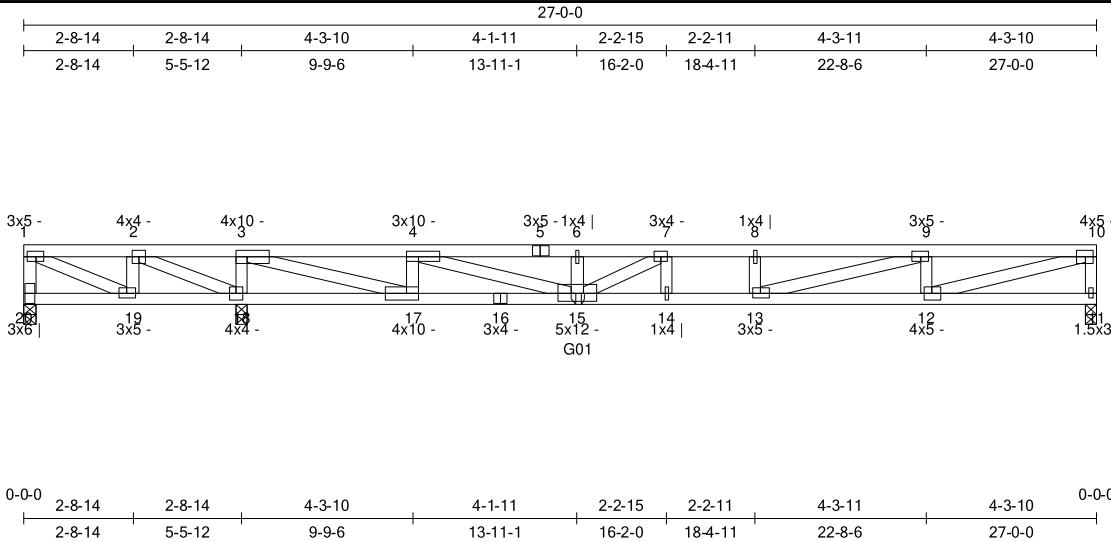

All plates shown to be Eagle 20 unless otherwise noted.

Loading (psf)	General	CSI	Deflection	L/	(loc)	Allowed
Carried Loads (psf)	Bldg Code: IBC 2018/	TC: 0.49 (2-3)	Vert TL: 0.43 in	L/591	(14-15)	L/240
TCLL: 40	TPI 1-2014	BC: 0.42 (14-15)	Vert LL: 0.16 in	L/999	(14-15)	L/360
TCDL: 10	Rep Mbr: No	Web: 0.58 (3-17)	Horz TL: 0.01 in		11	
BCLL: 0	Lumber D.O.L.: 115 %					
BCDL: 10						

Reaction

JT	Brg Combo	Brg Width	Rqd Brg Width	Max React	Max Grav Uplift	Max MWFRS Uplift	Max C&C Uplift	Max Uplift	Max Horiz
20	1	3.5 in	N/A	0 lbs	-1,038 lbs	-182 lbs	-119 lbs	-1,038 lbs	-63 lbs
18	1	3.5 in	1.68 in	4,056 lbs	.	.	-120 lbs	-120 lbs	.
11	1	3.5 in	1.50 in	1,243 lbs	.	.	-120 lbs	-120 lbs	.

12/04/2025

Material

TC: SYP2400/1.8 2 x 4
 BC: SYP2400/1.8 2 x 4
 Web: SYP#1 2 x 4

Bracing

TC: Sheathed or Purlins at 6-3-0, Purlin design by Others.
 BC: Sheathed or Purlins at 8-4-0, Purlin design by Others.



Loads

- This truss has been designed for the effects of balanced (20 psf) sloped roof snow loads in accordance with ASCE7 - 16 with the following user defined input: 20 psf GSL, Terrain C, Exposure (Ce = 1.0), Thermal (Ct = 1.00), DOL = 1.15. If the roof configuration differs from hip/gable, Building Designer shall verify snow loads.
- This truss has not been designed for the effects of unbalanced snow loads.
- This truss has been designed for the effects of wind loads in accordance with ASCE7 - 16 with the following user defined input: 115 mph (Factored), Exposure C, Enclosed, Gable/Hip, Risk Category II, Overall Bldg Dims 25 ft x 60 ft, h = 15 ft, End Zone Truss, Both end webs considered. DOL = 1.60
- Concurrent minimum storage attic loading has been applied in accordance with IBC 1607.1

Load Case Lr1: Std Live Load

Distributed Loads

Member	Location 1	Location 2	Direction	Spread	Start Load	End Load	Trib Width
Top	0-0-0	5-7-8	Down	Proj	50 plf	50 plf	
Top	5-7-8	6-11-10	Down	Proj	2.5 plf	5 plf	
Top	6-11-10	13-11-4	Down	Proj	5 plf	5 plf	
Top	13-11-4	27-0-0	Down	Proj	14.95 plf	14.95 plf	
Top	0-0-0	27-0-0	Down	Proj	50 plf	50 plf	

WARNING: Verify all design parameters and follow all notes on this drawing and in the Eagle Metal Design Notes. This design is for an individual building component (a truss), not a truss system, and is based only on parameters shown and provided by the Building Designer. The applicability of the design parameters must be verified by the Building Designer and should properly incorporate this design into the overall building design before use. Bracing shown is only to prevent buckling of individual truss web and/or chord members. Additional temporary and permanent bracing is always required to prevent collapse and provide stability. Design valid only when Eagle Metal connectors are used. A seal on this drawing indicates acceptance of professional engineering responsibility solely for the truss component design shown.

TrueBuild® Truss Software v5.8.14
 Eagle Metal Products

Quality Line Truss Co., LLC

34593 S 4350 RD
Address 2
Adair, OK 74330

Truss:G03

Job: LOT 7_H BUILDING_REF FRAMING

Date: 12/03/25 20:18:17

Page: 2 of 2

SPAN 27-0-0	PITCH 0/12	QTY 1	OHL 0-0-0	OHR 0-0-0	CANT L 0-0-0	CANT R 0-0-0	PLY(S) 2	SPACING 30 in	WGT/PLY 125 lbs
----------------	---------------	----------	--------------	--------------	-----------------	-----------------	-------------	------------------	--------------------

Load Case D1: Std Dead Load

Distributed Loads

Member	Location 1	Location 2	Direction	Spread	Start Load	End Load	Trib Width
Top	0-0-0	5-7-8	Down	Proj	12.5 plf	12.5 plf	
Top	5-7-8	6-11-10	Down	Proj	0.62 plf	1.25 plf	
Top	6-11-10	13-11-4	Down	Proj	1.25 plf	1.25 plf	
Top	13-11-4	27-0-0	Down	Proj	3.74 plf	3.74 plf	
Top	0-0-0	27-0-0	Down	Proj	12.5 plf	12.5 plf	
Bot	0-0-0	5-7-8	Down	Proj	12.5 plf	12.5 plf	
Bot	5-7-8	6-11-10	Down	Proj	0.62 plf	1.25 plf	
Bot	6-11-10	13-11-4	Down	Proj	1.25 plf	1.25 plf	
Bot	13-11-4	27-0-0	Down	Proj	3.74 plf	3.74 plf	
Bot	0-0-0	27-0-0	Down	Proj	12.5 plf	12.5 plf	

Member Forces

Table indicates: Member ID, max CSI, max tension force, (max compression force). Only forces greater than 300lbs are shown in this table.

TC	1-2	0.166	1,318 lbs	3-4	0.182	(-367 lbs)	6-7	0.265	(-3,130 lbs)	8-9	0.258	(-2,941 lbs)
	2-3	0.491	2,977 lbs	4-6	0.273	(-3,130 lbs)	7-8	0.249	(-2,941 lbs)	9-10	0.159	(-1,773 lbs)
BC	12-13	0.198	1,773 lbs	14-15	0.423	2,941 lbs	17-18	0.261	(-2,977 lbs)			
	13-14	0.423	2,941 lbs	15-17	0.120	367 lbs	18-19	0.157	(-1,318 lbs)			
Web	1-20	0.089	538 lbs	3-18	0.119	(-1,181 lbs)	7-15	0.075	451 lbs	10-11	0.060	(-597 lbs)
	1-19	0.155	(-1,454 lbs)	3-17	0.575	3,473 lbs	9-13	0.201	1,213 lbs			
	2-19	0.099	598 lbs	4-17	0.094	(-934 lbs)	9-12	0.051	(-501 lbs)			
	2-18	0.195	(-1,813 lbs)	4-15	0.477	2,879 lbs	10-12	0.306	1,847 lbs			

Truss to Truss Connection Summary

Carried Truss	Carrying Chord	Carrying Offset
G01	BC	13-11-4

Notes

- 1) Unless noted otherwise, do not cut or alter any truss member or plate without prior approval from a Professional Engineer.
- 2) The fabrication tolerance for this roof truss is 20 % (Cq = 0.80).
- 3) Provide adequate drainage to prevent ponding.
- 4) Brace bottom chord with approved sheathing or purlins per Bracing Summary.
- 5) A creep factor of 2.00 has been applied for this truss analysis.
- 6) The "SYP" label shown in the "Material Summary" above indicates the new SPIB design values effective June 1, 2013 were used.
- 7) Due to negative reactions in gravity load cases, special connections to the bearing surface at joint 20 may need to be considered.
- 8) The forces shown for this multi-ply truss are per ply and the reactions are for all plies. Two identical trusses shall be built and attached as follows, per ply: 10d Nails or Gun Nails [min 0.120"x2.875"] TC - 1 row @ 1-0-0 oc, BC - 1 row @ 1-0-0 oc, Webs - 1 row @ 1-0-0 oc.

Provided the hanger connections do not adequately transfer the applied load to all plies: in addition to connectors shown above, attach each pair of girder plies with supplemental 10d Nails or Gun Nails [min 0.120"x2.875"] as follows within 24" of the location shown:

BC: 13-11-4,(1)Connectors

Connectors shall not encroach on other girder ply connectors or truss-to-truss connectors in accordance with the NDS or the connector manufacturer recommendations.

- 9) When applied loads are on one side of girder, do not flip girder during girder connector installation, install connectors on the girder side where supported loads are applied. When applied loads are on both sides of girder, double the spacing and install half of the connectors on one side of girder and then flip the girder to install the other half of the connectors on the opposite side (at double the connector spacing). Connectors on opposite sides of the girder shall be offset.
- 10) Lateral bracing shall be attached to each ply.
- 11) All fasteners minimum 2-1/2" long, unless otherwise noted.
- 12) Nails in 1st and 2nd ply shall be offset from successive plies by 1/2 the nail spacing.
- 13) Listed wind uplift reactions based on MWFRS & C&C loading.

WARNING: Verify all design parameters and follow all notes on this drawing and in the Eagle Metal Design Notes. This design is for an individual building component (a truss), not a truss system, and is based only on parameters shown and provided by the Building Designer. The applicability of the design parameters must be verified by the Building Designer and should properly incorporate this design into the overall building design before use. Bracing shown is only to prevent buckling of individual truss web and/or chord members. Additional temporary and permanent bracing is always required to prevent collapse and provide stability. Design valid only when Eagle Metal connectors are used. A seal on this drawing indicates acceptance of professional engineering responsibility solely for the truss component design shown.

TrueBuild® Truss Software v5.8.14
Eagle Metal Products

Quality Line Truss Co., LLC

34593 S 4350 RD

Address 2

Adair, OK 74330

Truss:GE01

Job: LOT 7_H BUILDING_REF FRAMING

Date: 12/03/25 20:17:59

Page: 1 of 1

SPAN 27-0-0	PITCH 4/12	QTY 1	OHL 1-4-0	OHR 1-4-0	CANT L 0-0-0	CANT R 0-0-0	PLY(S) 1	SPACING 24 in	WGT/PLY 121 lbs
----------------	---------------	----------	--------------	--------------	-----------------	-----------------	-------------	------------------	--------------------

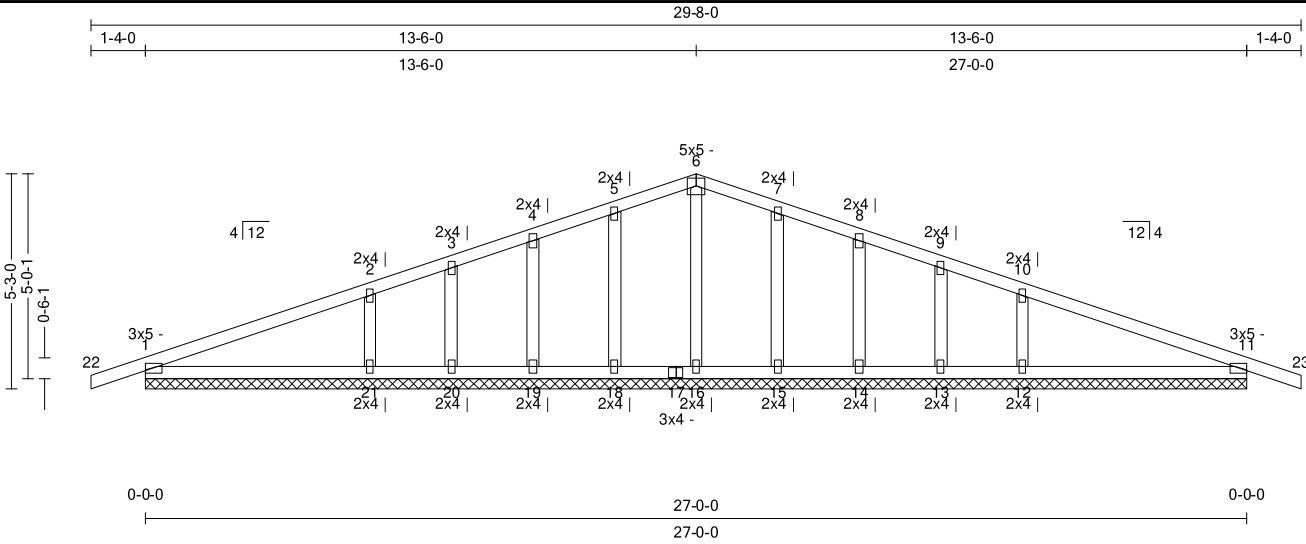

All plates shown to be Eagle 20 unless otherwise noted.

Loading (psf)	General	CSI	Deflection	L/	(loc)	Allowed
TCLL: 20	Bldg Code: IBC 2018/	TC: 0.29 (10-11)	Vert TL: 0.01 in	L/999	(11-12)	L/240
TCDL: 10	TPI 1-2014	BC: 0.11 (11-12)	Vert LL: 0 in	L/999	11	L/360
BCLL: 0	Rep Mbr: No	Web: 0.04 (5-18)	Horz TL: 0 in			
BCDL: 10	Lumber D.O.L.: 115 %					

12/04/2025

Reaction

Brg Combo	Brg Width	Max React	Ave React	Max Grav Uplift	Max MWFRS Uplift	Max C&C Uplift	Max Uplift	Max Horiz
1		885 lbs	137 plf	-556 lbs	-116 lbs	-128 lbs	-556 lbs	-503 lbs

Material

TC: SYP#1 2 x 4
BC: SYP#1 2 x 4
Web: SYP#2 2 x 4

Bracing

TC: Sheathed or Purlins at 6-3-0, Purlin design by Others.
BC: Sheathed or Purlins at 10-0-0, Purlin design by Others.

Loads

- This truss has been designed for the effects of balanced (14 psf) and unbalanced sloped roof snow loads in accordance with ASCE7 - 16 with the following user defined input: 20 psf GSL, Terrain C, Exposure (Ce = 1.0), Thermal (Ct = 1.00), DOL = 1.15. If the roof configuration differs from hip/gable, Building Designer shall verify snow loads.
- This truss has been designed to account for the effects of ice dams forming at the eaves.
- This truss has been designed for the effects of wind loads in accordance with ASCE7 - 16 with the following user defined input: 115 mph (Factored), Exposure C, Enclosed, Gable/Hip, Risk Category II, Overall Bldg Dims 25 ft x 60 ft, h = 15 ft, End Zone Truss, Both end webs considered. DOL = 1.60

Member Forces

Table indicates: Member ID, max CSI, max tension force, (max compression force). Only forces greater than 300lbs are shown in this table.

Member	Member ID	max CSI	max tension force	max compression force
TC	1-2	0.289	729 lbs	
	10-11	0.289	729 lbs	
BC				
Web				

Notes

- Unless noted otherwise, do not cut or alter any truss member or plate without prior approval from a Professional Engineer.
- Gable requires continuous bottom chord bearing.
- Gable webs placed at 24" OC, U.N.O.
- Attach gable webs with 2x4 20ga plates, U.N.O.
- Bracing shown is for in-plane requirements. For out-of-plane requirements, refer to BCSI-B3 published by the SBCA.
- The fabrication tolerance for this roof truss is 20% (Cq = 0.80).
- A creep factor of 2.00 has been applied for this truss analysis.
- The "SYP" label shown in the "Material Summary" above indicates the new SPIB design values effective June 1, 2013 were used.
- Due to negative reactions in gravity load cases, special connections to the bearing surface at joints 11, 1 may need to be considered.
- Listed wind uplift reactions based on MWFRS & C&C loading.



WARNING: Verify all design parameters and follow all notes on this drawing and in the Eagle Metal Design Notes. This design is for an individual building component (a truss), not a truss system, and is based only on parameters shown and provided by the Building Designer. The applicability of the design parameters must be verified by the Building Designer and should properly incorporate this design into the overall building design before use. Bracing shown is only to prevent buckling of individual truss web and/or chord members. Additional temporary and permanent bracing is always required to prevent collapse and provide stability. Design valid only when Eagle Metal connectors are used. A seal on this drawing indicates acceptance of professional engineering responsibility solely for the truss component design shown.

TrueBuild® Truss Software v5.8.14
Eagle Metal Products

1253550 0016/0024

Quality Line Truss Co., LLC

34593 S 4350 RD
Address 2
Adair, OK 74330

Truss:GE02

Job: LOT 7_H BUILDING_REF FRAMING

Date: 12/03/25 20:18:00

Page: 1 of 1

SPAN 20-0-0	PITCH 5/12	QTY 1	OHL 1-4-0	OHR 1-4-0	CANT L 0-0-0	CANT R 0-0-0	PLY(S) 1	SPACING 24 in	WGT/PLY 91 lbs
----------------	---------------	----------	--------------	--------------	-----------------	-----------------	-------------	------------------	-------------------

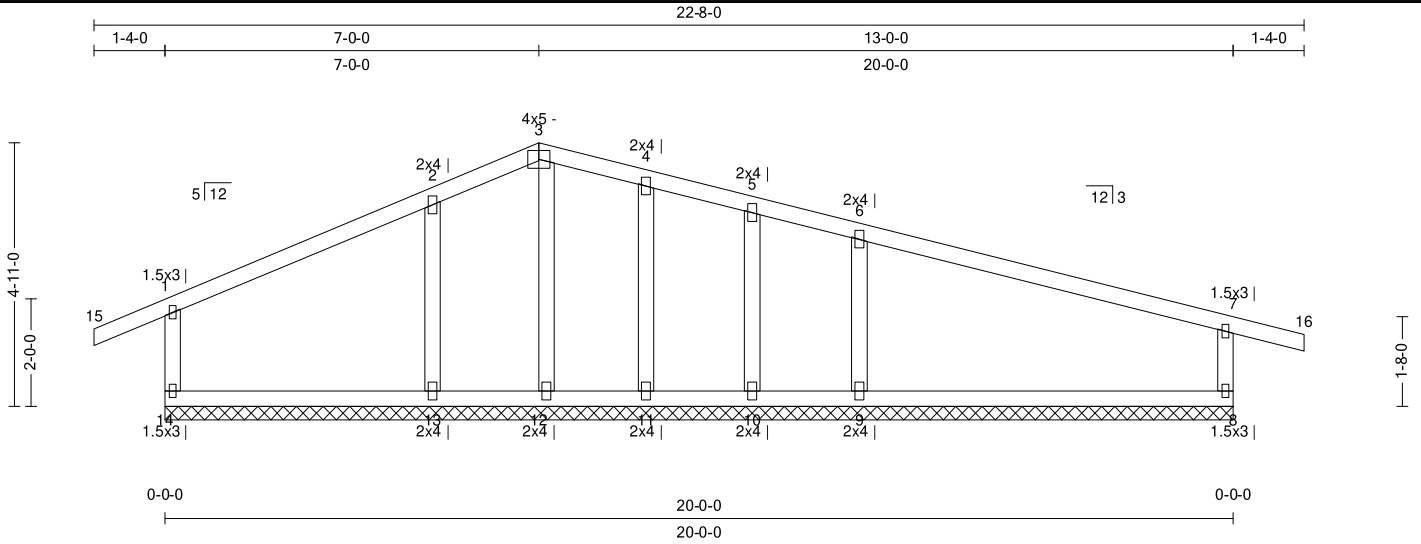

All plates shown to be Eagle 20 unless otherwise noted.

Loading (psf)	General	CSI	Deflection	L/	(loc)	Allowed
TCLL: 20	Bldg Code: IBC 2018/	TC: 0.43 (6-7)	Vert TL: 0.06 in	L/999	(8-9)	L/240
TCDL: 10	TPI 1-2014	BC: 0.27 (9-10)	Vert LL: 0 in	L/999	8	L/360
BCLL: 0	Rep Mbr: No	Web: 0.33 (1-14)	Horz TL: 0 in			
BCDL: 10	Lumber D.O.L.: 115 %					

Reaction

Brg Combo	Brg Width	Max React	Ave React	Max Grav Uplift	Max MWFRS Uplift	Max C&C Uplift	Max Uplift	Max Horiz
1		552 lbs	97 plf	-47 lbs	-83 lbs	-230 lbs	-230 lbs	61 lbs

Material

TC: SYP#1 2 x 4
BC: SYP#1 2 x 4
Web: SYP#2 2 x 4

Bracing

TC: Sheathed or Purlins at 6-3-0, Purlin design by Others.
BC: Sheathed or Purlins at 10-0-0, Purlin design by Others.

Loads

- This truss has been designed for the effects of balanced (14 psf) and unbalanced sloped roof snow loads in accordance with ASCE7 - 16 with the following user defined input: 20 psf GSL, Terrain C, Exposure (Ce = 1.0), Thermal (Ct = 1.00), DOL = 1.15. If the roof configuration differs from hip/gable, Building Designer shall verify snow loads.
- This truss has been designed to account for the effects of ice dams forming at the eaves.
- This truss has been designed for the effects of wind loads in accordance with ASCE7 - 16 with the following user defined input: 115 mph (Factored), Exposure C, Enclosed, Gable/Hip, Risk Category II, Overall Bldg Dims 25 ft x 60 ft, h = 15 ft, End Zone Truss, Both end webs considered. DOL = 1.60

Member Forces

Table indicates: Member ID, max CSI, max tension force, (max compression force). Only forces greater than 300lbs are shown in this table.

TC	BC	Web
		69 0.076 (-399 lbs)

Notes

- Unless noted otherwise, do not cut or alter any truss member or plate without prior approval from a Professional Engineer.
- Gable requires continuous bottom chord bearing.
- Gable webs placed at 24" OC, U.N.O.
- Attach gable webs with 2x4 20ga plates, U.N.O.
- Bracing shown is for in-plane requirements. For out-of-plane requirements, refer to BCSI-B3 published by the SBCA.
- The fabrication tolerance for this roof truss is 20% (Cq = 0.80).
- A creep factor of 2.00 has been applied for this truss analysis.
- The "SYP" label shown in the "Material Summary" above indicates the new SPIB design values effective June 1, 2013 were used.
- Due to negative reactions in gravity load cases, special connections to the bearing surface at joint 10 may need to be considered.
- Listed wind uplift reactions based on MWFRS & C&C loading.

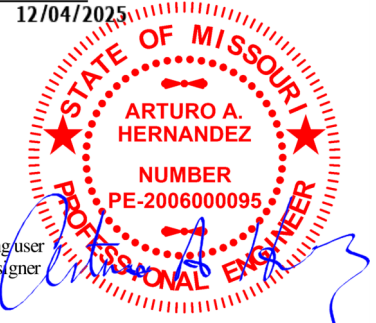

WARNING: Verify all design parameters and follow all notes on this drawing and in the Eagle Metal Design Notes. This design is for an individual building component (a truss), not a truss system, and is based only on parameters shown and provided by the Building Designer. The applicability of the design parameters must be verified by the Building Designer and should properly incorporate this design into the overall building design before use. Bracing shown is only to prevent buckling of individual truss web and/or chord members. Additional temporary and permanent bracing is always required to prevent collapse and provide stability. Design valid only when Eagle Metal connectors are used. A seal on this drawing indicates acceptance of professional engineering responsibility solely for the truss component design shown.

TrueBuild® Truss Software v5.8.14
Eagle Metal Products

Quality Line Truss Co., LLC

34593 S 4350 RD
Address 2
Adair, OK 74330

Truss:GE03

Job: LOT 7_H BUILDING_REF FRAMING

Date: 12/03/25 20:18:02

Page: 1 of 1

SPAN 13-11-0	PITCH 4/12	QTY 1	OHL 1-4-0	OHR 1-4-0	CANT L 0-0-0	CANT R 0-0-0	PLY(S) 1	SPACING 24 in	WGT/PLY 71 lbs
-----------------	---------------	----------	--------------	--------------	-----------------	-----------------	-------------	------------------	-------------------

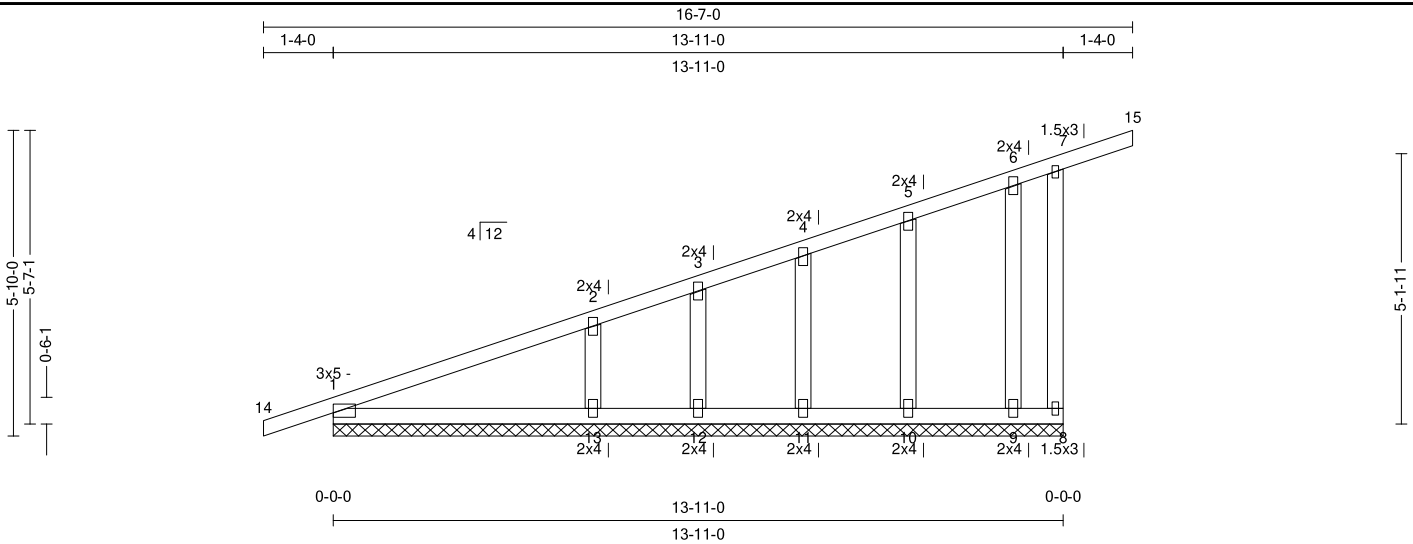

All plates shown to be Eagle 20 unless otherwise noted.

Loading (psf)	General	CSI	Deflection	L/	(loc)	Allowed
TCLL: 20	Bldg Code: IBC 2018/	TC: 0.27 (6-7)	Vert TL: 0.01 in	L/999	(13-1)	L/240
TCDL: 10	TPI 1-2014	BC: 0.09 (13-1)	Vert LL: 0 in	L/999	8	L/360
BCLL: 0	Rep Mbr: No	Web: 0.23 (7-8)	Horz TL: 0 in			
BCDL: 10	Lumber D.O.L.: 115 %					

Reaction								
Brg Combo	Brg Width	Max React	Ave React	Max Grav Uplift	Max MWFRS Uplift	Max C&C Uplift	Max Uplift	Max Horiz
1		818 lbs	152 plf	-535 lbs	-165 lbs	-389 lbs	-535 lbs	-435 lbs

Material
TC: SYP#1 2 x 4
BC: SYP#1 2 x 4
Web: SYP#2 2 x 4

Bracing
TC: Sheathed or Purlins at 6-3-0, Purlin design by Others.
BC: Sheathed or Purlins at 10-0-0, Purlin design by Others.

Loads
1) This truss has been designed for the effects of balanced (14 psf) and unbalanced sloped roof snow loads in accordance with ASCE7 - 16 with the following user defined input: 20 psf GSL, Terrain C, Exposure (Ce = 1.0), Thermal (Ct = 1.00), DOL = 1.15. If the roof configuration differs from hip/gable, Building Designer shall verify snow loads.
2) This truss has been designed to account for the effects of ice dams forming at the eaves.
3) This truss has been designed for the effects of wind loads in accordance with ASCE7 - 16 with the following user defined input: 115 mph (Factored), Exposure C, Enclosed, Gable/Hip, Risk Category II, Overall Bldg Dims 25 ft x 60 ft, h = 15 ft, End Zone Truss, Both end webs considered. DOL = 1.60

Member Forces Table indicates: Member ID, max CSI, max tension force, (max compression force). Only forces greater than 300lbs are shown in this table.

Member	Force
TC 1-2	0.255 678 lbs (-417 lbs)
BC	
Web	

- Notes**
- 1) Unless noted otherwise, do not cut or alter any truss member or plate without prior approval from a Professional Engineer.
 - 2) Gable requires continuous bottom chord bearing.
 - 3) Gable webs placed at 24" OC, U.N.O.
 - 4) Attach gable webs with 2x4 20ga plates, U.N.O.
 - 5) Bracing shown is for in-plane requirements. For out-of-plane requirements, refer to BCSI-B3 published by the SBCA.
 - 6) The fabrication tolerance for this roof truss is 20% (Cq = 0.80).
 - 7) A creep factor of 2.00 has been applied for this truss analysis.
 - 8) The "SYP" label shown in the "Material Summary" above indicates the new SPIB design values effective June 1, 2013 were used.
 - 9) Due to negative reactions in gravity load cases, special connections to the bearing surface at joint 1 may need to be considered.
 - 10) Listed wind uplift reactions based on MWFRS & C&C loading.



WARNING: Verify all design parameters and follow all notes on this drawing and in the Eagle Metal Design Notes. This design is for an individual building component (a truss), not a truss system, and is based only on parameters shown and provided by the Building Designer. The applicability of the design parameters must be verified by the Building Designer and should properly incorporate this design into the overall building design before use. Bracing shown is only to prevent buckling of individual truss web and/or chord members. Additional temporary and permanent bracing is always required to prevent collapse and provide stability. Design valid only when Eagle Metal connectors are used. A seal on this drawing indicates acceptance of professional engineering responsibility solely for the truss component design shown.

TrueBuild® Truss Software v5.8.14
Eagle Metal Products

Quality Line Truss Co., LLC

34593 S 4350 RD
Address 2
Adair, OK 74330

Truss:T01

Job: LOT 7_H BUILDING_REF FRAMING

Date: 12/03/25 20:18:03

Page: 1 of 1

SPAN 27-0-0	PITCH 4/12	QTY 14	OHL 1-4-0	OHR 1-4-0	CANT L 0-0-0	CANT R 0-0-0	PLY(S) 1	SPACING 24 in	WGT/PLY 108 lbs
----------------	---------------	-----------	--------------	--------------	-----------------	-----------------	-------------	------------------	--------------------

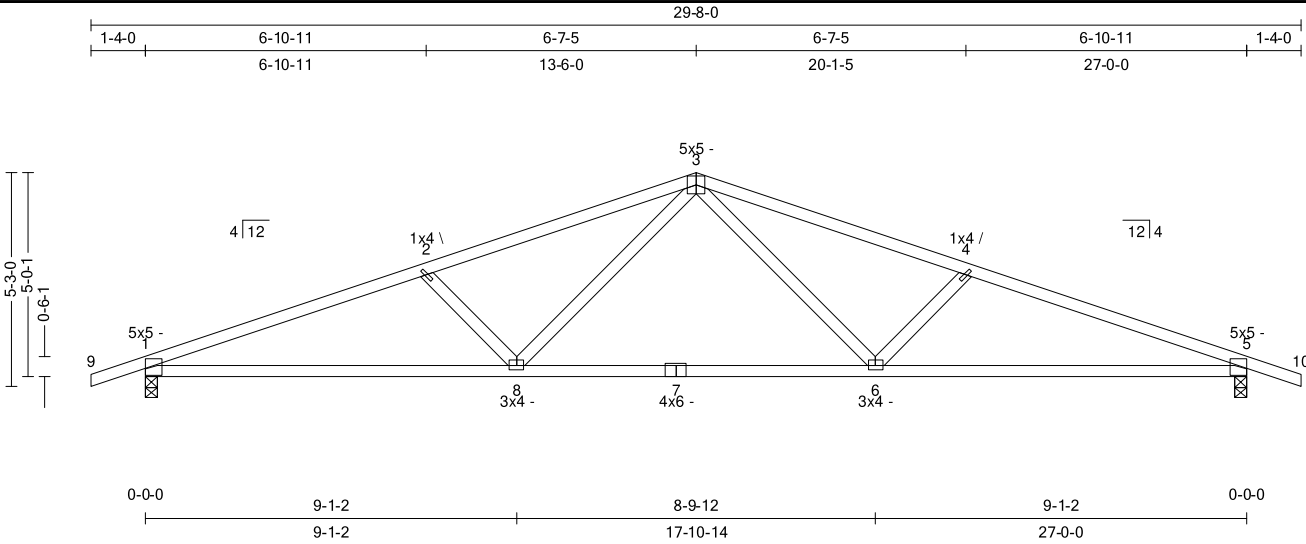

All plates shown to be Eagle 20 unless otherwise noted.

Loading (psf)	General	CSI	Deflection	L/	(loc)	Allowed
TCLL: 20	Bldg Code: IBC 2018/	TC: 0.52 (2-3)	Vert TL: 0.48 in	L/ 654	(6-7)	L/ 240
TCDL: 10	TPI 1-2014	BC: 0.89 (8-1)	Vert LL: 0.16 in	L/ 999	7	L/ 360
BCLL: 0	Rep Mbr: Yes	Web: 0.14 (3-8)	Horz TL: 0.1 in		5	
BCDL: 10	Lumber D.O.L.: 115 %					

Reaction

JT	Brg Combo	Brg Width	Rqd Brg Width	Max React	Max Grav Uplift	Max MWFRS Uplift	Max C&C Uplift	Max Uplift	Max Horiz
1	1	3.5 in	1.69 in	1,430 lbs		-112 lbs	-331 lbs	-331 lbs	-6 lbs
5	1	3.5 in	1.69 in	1,430 lbs		-112 lbs	-331 lbs	-331 lbs	

Material

TC: SYP#1 2 x 4
BC: SYP#1 2 x 4
Web: SYP#1 2 x 4

Bracing

TC: Sheathed or Purlins at 3-4-0, Purlin design by Others.
BC: Sheathed or Purlins at 9-9-0, Purlin design by Others.

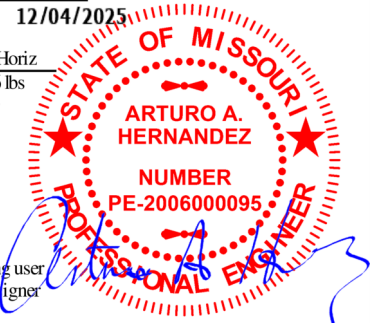

Loads

- This truss has been designed for the effects of balanced (14 psf) and unbalanced sloped roof snow loads in accordance with ASCE7 - 16 with the following user defined input: 20 psf GSL, Terrain C, Exposure (Ce = 1.0), Thermal (Ct = 1.00), DOL = 1.15. If the roof configuration differs from hip/gable, Building Designer shall verify snow loads.
- This truss has been designed to account for the effects of ice dams forming at the eaves.
- This truss has been designed for the effects of wind loads in accordance with ASCE7 - 16 with the following user defined input: 115 mph (Factored), Exposure C, Enclosed, Gable/Hip, Risk Category II, Overall Bldg Dims 25 ft x 60 ft, h = 15 ft, End Zone Truss, Both end webs considered. DOL = 1.60
- Concurrent minimum storage attic loading has been applied in accordance with IBC 1607.1

Member Forces

Table indicates: Member ID, max CSI, max tension force, (max compression force). Only forces greater than 300lbs are shown in this table.

TC	1-2	0.485	566 lbs	(-3,022 lbs)	3-4	0.523	516 lbs	(-2,735 lbs)							
	2-3	0.523	516 lbs	(-2,735 lbs)	4-5	0.485	566 lbs	(-3,022 lbs)							
BC	5-6	0.885	2,804 lbs	(-425 lbs)	6-8	0.756	1,946 lbs	(-425 lbs)	8-1	0.885	2,804 lbs	(-425 lbs)			
Web	2-8	0.080		(-418 lbs)	3-8	0.143	865 lbs		3-6	0.143	865 lbs		4-6	0.080	(-418 lbs)

Notes

- Unless noted otherwise, do not cut or alter any truss member or plate without prior approval from a Professional Engineer.
- The fabrication tolerance for this roof truss is 20 % (Cq = 0.80).
- Brace bottom chord with approved sheathing or purlins per Bracing Summary.
- A creep factor of 2.00 has been applied for this truss analysis.
- The "SYP" label shown in the "Material Summary" above indicates the new SPIB design values effective June 1, 2013 were used.
- Listed wind uplift reactions based on MWFRS & C&C loading.

WARNING: Verify all design parameters and follow all notes on this drawing and in the Eagle Metal Design Notes. This design is for an individual building component (a truss), not a truss system, and is based only on parameters shown and provided by the Building Designer. The applicability of the design parameters must be verified by the Building Designer and should properly incorporate this design into the overall building design before use. Bracing shown is only to prevent buckling of individual truss web and/or chord members. Additional temporary and permanent bracing is always required to prevent collapse and provide stability. Design valid only when Eagle Metal connectors are used. A seal on this drawing indicates acceptance of professional engineering responsibility solely for the truss component design shown.

TrueBuild® Truss Software v5.8.14
Eagle Metal Products

Quality Line Truss Co., LLC

34593 S 4350 RD
Address 2
Adair, OK 74330

Truss:T02

Job: LOT 7_H BUILDING_REFRAMING

Date: 12/03/25 20:18:05

Page: 1 of 1

SPAN 27-0-0	PITCH 4/12	QTY 1	OHL 1-4-0	OHR 1-4-0	CANT L 0-0-0	CANT R 0-0-0	PLY(S) 1	SPACING 24 in	WGT/PLY 140 lbs
----------------	---------------	----------	--------------	--------------	-----------------	-----------------	-------------	------------------	--------------------

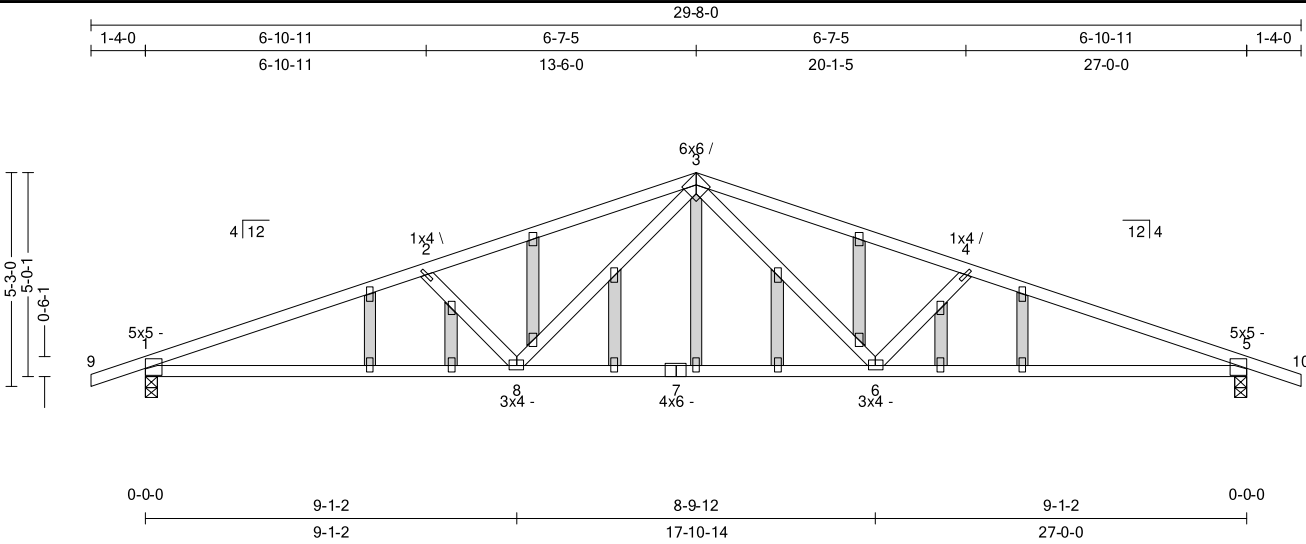

All plates shown to be Eagle 20 unless otherwise noted.

Loading (psf)	General	CSI	Deflection	L/	(loc)	Allowed
TCLL: 20	Bldg Code: IBC 2018/	TC: 0.62 (2-3)	Vert TL: 0.48 in	L/ 654	(6-7)	L/ 240
TCDL: 10	TPI 1-2014	BC: 1.00 (8-1)	Vert LL: 0.16 in	L/ 999	7	L/ 360
BCLL: 0	Rep Mbr: No	Web: 0.14 (3-8)	Horz TL: 0.1 in		5	
BCDL: 10	Lumber D.O.L.: 115 %					

Reaction

JT	Brg Combo	Brg Width	Rqd Brg Width	Max React	Max Grav Uplift	Max MWFRS Uplift	Max C&C Uplift	Max Uplift	Max Horiz
1	1	3.5 in	1.69 in	1,430 lbs		-112 lbs	-331 lbs	-331 lbs	-6 lbs
5	1	3.5 in	1.69 in	1,430 lbs		-112 lbs	-331 lbs	-331 lbs	

Material

TC: SYP#1 2 x 4
BC: SYP#1 2 x 4
Web: SYP#1 2 x 4

Bracing

TC: Sheathed or Purlins at 3-2-0, Purlin design by Others.
BC: Sheathed or Purlins at 9-3-0, Purlin design by Others.

12/04/2025

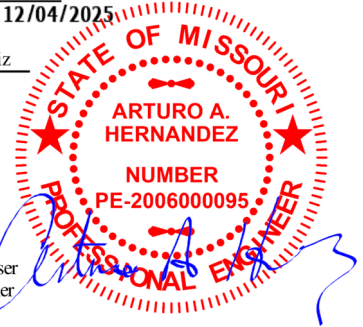

Loads

- This truss has been designed for the effects of balanced (14 psf) and unbalanced sloped roof snow loads in accordance with ASCE7 - 16 with the following user defined input: 20 psf GSL, Terrain C, Exposure (Ce = 1.0), Thermal (Ct = 1.00), DOL = 1.15. If the roof configuration differs from hip/gable, Building Designer shall verify snow loads.
- This truss has been designed to account for the effects of ice dams forming at the eaves.
- This truss has been designed for the effects of wind loads in accordance with ASCE7 - 16 with the following user defined input: 115 mph (Factored), Exposure C, Enclosed, Gable/Hip, Risk Category II, Overall Bldg Dims 25 ft x 60 ft, h = 15 ft, End Zone Truss, Both end webs considered. DOL = 1.60
- Concurrent minimum storage attic loading has been applied in accordance with IBC 1607.1

Member Forces

Table indicates: Member ID, max CSI, max tension force, (max compression force). Only forces greater than 300lbs are shown in this table.

TC	1-2	0.562	566 lbs	(-3,022 lbs)	3-4	0.619	516 lbs	(-2,735 lbs)				
	2-3	0.619	516 lbs	(-2,735 lbs)	4-5	0.562	566 lbs	(-3,022 lbs)				
BC	5-6	0.997	2,804 lbs	(-425 lbs)	6-8	0.855	1,946 lbs	(-425 lbs)	8-1	0.997	2,804 lbs	(-425 lbs)
Web	2-8	0.080		(-418 lbs)	3-8	0.143	865 lbs		3-6	0.143	865 lbs	
									4-6	0.080		(-418 lbs)

Notes

- Unless noted otherwise, do not cut or alter any truss member or plate without prior approval from a Professional Engineer.
- Gable webs placed at 24" OC, U.N.O.
- Attach structural gable blocks with 2x4 20ga plates, U.N.O.
- Bracing shown is for in-plane requirements. For out-of-plane requirements, refer to BCSI-B3 published by the SBCA.
- The fabrication tolerance for this roof truss is 20% (Cq = 0.80).
- A creep factor of 2.00 has been applied for this truss analysis.
- The "SYP" label shown in the "Material Summary" above indicates the new SPIB design values effective June 1, 2013 were used.
- Indicates non-structural members.
- Listed wind uplift reactions based on MWFRS & C&C loading.

WARNING: Verify all design parameters and follow all notes on this drawing and in the Eagle Metal Design Notes. This design is for an individual building component (a truss), not a truss system, and is based only on parameters shown and provided by the Building Designer. The applicability of the design parameters must be verified by the Building Designer and should properly incorporate this design into the overall building design before use. Bracing shown is only to prevent buckling of individual truss web and/or chord members. Additional temporary and permanent bracing is always required to prevent collapse and provide stability. Design valid only when Eagle Metal connectors are used. A seal on this drawing indicates acceptance of professional engineering responsibility solely for the truss component design shown.

TrueBuild® Truss Software v5.8.14
Eagle Metal Products

Quality Line Truss Co., LLC

34593 S 4350 RD
Address 2
Adair, OK 74330

Truss:T03

Job: LOT 7_H BUILDING_REF FRAMING

Date: 12/03/25 20:18:06

Page: 1 of 1

SPAN 13-11-0	PITCH 4/12	QTY 1	OHL 1-4-0	OHR 1-4-0	CANT L 0-0-0	CANT R 0-0-0	PLY(S) 1	SPACING 24 in	WGT/PLY 63 lbs
-----------------	---------------	----------	--------------	--------------	-----------------	-----------------	-------------	------------------	-------------------

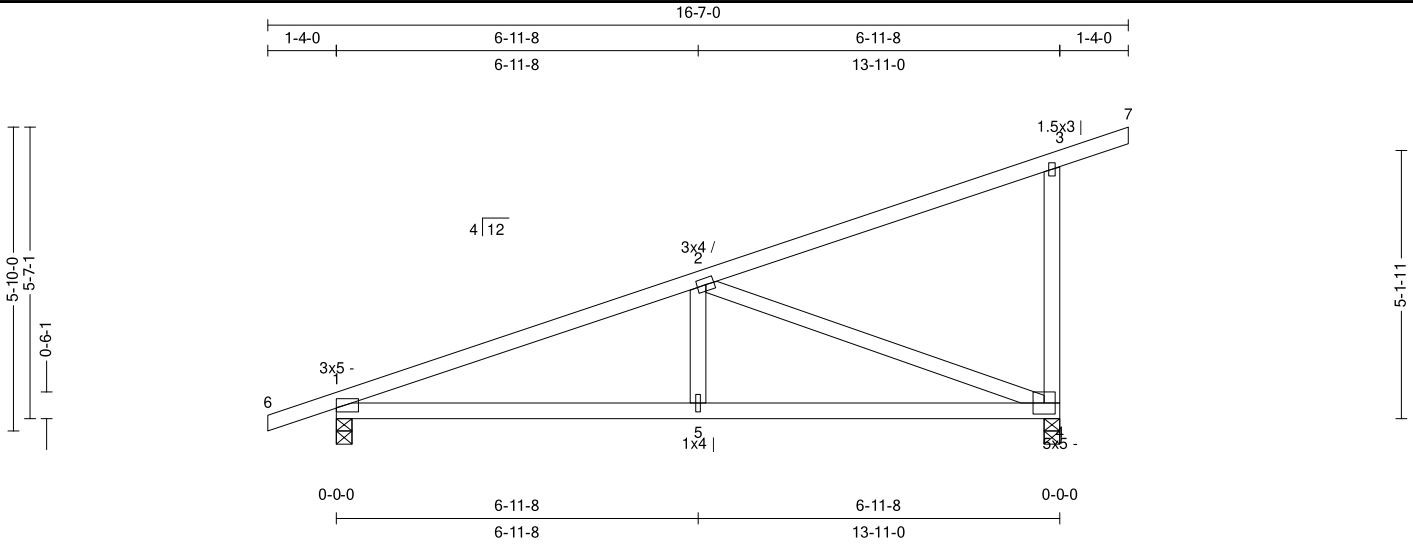

All plates shown to be Eagle 20 unless otherwise noted.

Loading (psf)	General	CSI	Deflection	L/	(loc)	Allowed
TCLL: 20	Bldg Code: IBC 2018/	TC: 0.51 (2-3)	Vert TL: 0.15 in	L/999	(4-5)	L/240
TCDL: 10	TPI 1-2014	BC: 0.65 (5-1)	Vert LL: 0.06 in	L/999	(4-5)	L/360
BCLL: 0	Rep Mbr: No	Web: 0.94 (2-4)	Horz TL: 0.02 in		4	
BCDL: 10	Lumber D.O.L.: 115 %					

12/04/2025

Reaction

JT	Brg Combo	Brg Width	Rqd Brg Width	Max React	Max Grav Uplift	Max MWFRS Uplift	Max C&C Uplift	Max Uplift	Max Horiz
1	1	3.5 in	1.50 in	768 lbs		-38 lbs	-322 lbs	-322 lbs	189 lbs
4	1	3.5 in	1.50 in	784 lbs		-101 lbs	-393 lbs	-393 lbs	

Material

TC: SYP#1 2 x 4
BC: SYP#1 2 x 4
Web: SYP#1 2 x 4

Bracing

TC: Sheathed or Purlins at 5-0-0, Purlin design by Others.
BC: Sheathed or Purlins at 10-0-0, Purlin design by Others.

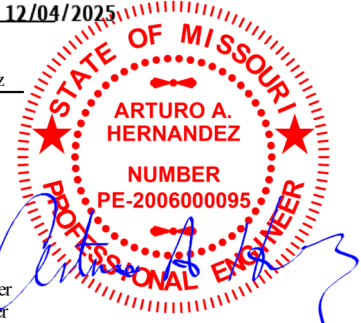

Loads

- 1) This truss has been designed for the effects of balanced (14 psf) and unbalanced sloped roof snow loads in accordance with ASCE7 - 16 with the following user defined input: 20 psf GSL, Terrain C, Exposure (Ce = 1.0), Thermal (Ct = 1.00), DOL = 1.15. If the roof configuration differs from hip/gable, Building Designer shall verify snow loads.
- 2) This truss has been designed to account for the effects of ice dams forming at the eaves.
- 3) This truss has been designed for the effects of wind loads in accordance with ASCE7 - 16 with the following user defined input: 115 mph (Factored), Exposure C, Enclosed, Gable/Hip, Risk Category II, Overall Bldg Dims 25 ft x 60 ft, h = 15 ft, End Zone Truss, Both end webs considered. DOL = 1.60
- 4) Concurrent minimum storage attic loading has been applied in accordance with IBC 1607.1

Member Forces

Table indicates: Member ID, max CSI, max tension force, (max compression force). Only forces greater than 300lbs are shown in this table.

TC	1-2	0.505	324 lbs	(-1,219 lbs)	5-1	0.654	1,102 lbs	(-352 lbs)
BC	4-5	0.654	1,102 lbs	(-352 lbs)	5-1	0.654	1,102 lbs	(-352 lbs)
Web	2-5	0.055	334 lbs		2-4	0.937	479 lbs	(-1,175 lbs)

Notes

- 1) Unless noted otherwise, do not cut or alter any truss member or plate without prior approval from a Professional Engineer.
- 2) The fabrication tolerance for this roof truss is 20 % (Cq = 0.80).
- 3) Brace bottom chord with approved sheathing or purlins per Bracing Summary.
- 4) A creep factor of 2.00 has been applied for this truss analysis.
- 5) The "SYP" label shown in the "Material Summary" above indicates the new SPIB design values effective June 1, 2013 were used.
- 6) Listed wind uplift reactions based on MWFRS & C&C loading.

WARNING: Verify all design parameters and follow all notes on this drawing and in the Eagle Metal Design Notes. This design is for an individual building component (a truss), not a truss system, and is based only on parameters shown and provided by the Building Designer. The applicability of the design parameters must be verified by the Building Designer and should properly incorporate this design into the overall building design before use. Bracing shown is only to prevent buckling of individual truss web and/or chord members. Additional temporary and permanent bracing is always required to prevent collapse and provide stability. Design valid only when Eagle Metal connectors are used. A seal on this drawing indicates acceptance of professional engineering responsibility solely for the truss component design shown.

TrueBuild® Truss Software v5.8.14
Eagle Metal Products

Quality Line Truss Co., LLC

34593 S 4350 RD
Address 2
Adair, OK 74330

Truss:T04

Job: LOT 7_H BUILDING_REF FRAMING

Date: 12/03/25 20:18:07

Page: 1 of 1

SPAN 13-11-0	PITCH 4/12	QTY 1	OHL 1-4-0	OHR 1-4-0	CANT L 0-0-0	CANT R 0-0-0	PLY(S) 1	SPACING 24 in	WGT/PLY 63 lbs
-----------------	---------------	----------	--------------	--------------	-----------------	-----------------	-------------	------------------	-------------------

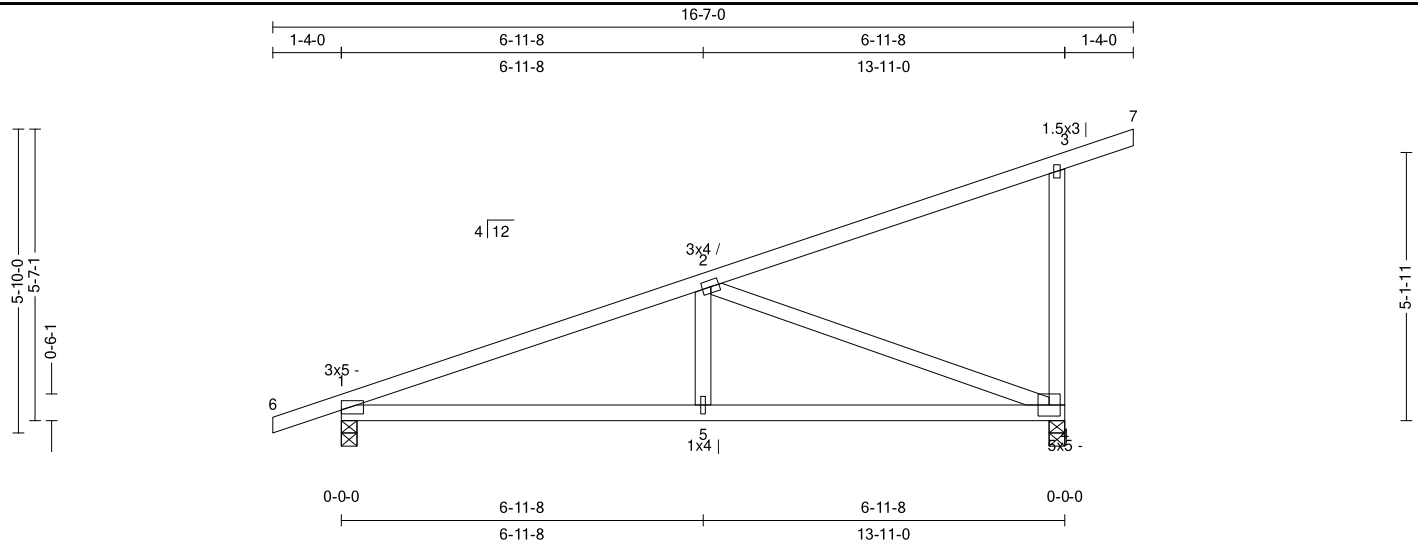

All plates shown to be Eagle 20 unless otherwise noted.

Loading (psf)	General	CSI	Deflection	L/	(loc)	Allowed
TCLL: 20	Bldg Code: IBC 2018/	TC: 0.51 (2-3)	Vert TL: 0.15 in	L/999	(4-5)	L/240
TCDL: 10	TPI 1-2014	BC: 0.65 (5-1)	Vert LL: 0.06 in	L/999	(4-5)	L/360
BCLL: 0	Rep Mbr: No	Web: 0.94 (2-4)	Horz TL: 0.02 in		4	
BCDL: 10	Lumber D.O.L.: 115 %					

12/04/2025

Reaction

JT	Brg Combo	Brg Width	Rqd Brg Width	Max React	Max Grav Uplift	Max MWFRS Uplift	Max C&C Uplift	Max Uplift	Max Horiz
1	1	3.5 in	1.50 in	768 lbs		-38 lbs	-322 lbs	-322 lbs	189 lbs
4	1	3.5 in	1.50 in	784 lbs		-101 lbs	-393 lbs	-393 lbs	

Material

TC: SYP#1 2 x 4
BC: SYP#1 2 x 4
Web: SYP#1 2 x 4

Bracing

TC: Sheathed or Purlins at 5-0-0, Purlin design by Others.
BC: Sheathed or Purlins at 10-0-0, Purlin design by Others.

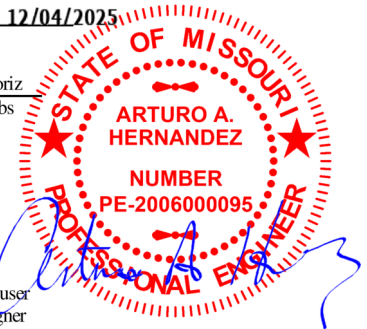

Loads

- 1) This truss has been designed for the effects of balanced (14 psf) and unbalanced sloped roof snow loads in accordance with ASCE7 - 16 with the following user defined input: 20 psf GSL, Terrain C, Exposure (Ce = 1.0), Thermal (Ct = 1.00), DOL = 1.15. If the roof configuration differs from hip/gable, Building Designer shall verify snow loads.
- 2) This truss has been designed to account for the effects of ice dams forming at the eaves.
- 3) This truss has been designed for the effects of wind loads in accordance with ASCE7 - 16 with the following user defined input: 115 mph (Factored), Exposure C, Enclosed, Gable/Hip, Risk Category II, Overall Bldg Dims 25 ft x 60 ft, h = 15 ft, End Zone Truss, Both end webs considered. DOL = 1.60
- 4) Concurrent minimum storage attic loading has been applied in accordance with IBC 1607.1

Member Forces

Table indicates: Member ID, max CSI, max tension force, (max compression force). Only forces greater than 300lbs are shown in this table.

TC	1-2	0.505	324 lbs	(-1,219 lbs)	5-1	0.654	1,102 lbs	(-352 lbs)
BC	4-5	0.654	1,102 lbs	(-352 lbs)	5-1	0.654	1,102 lbs	(-352 lbs)
Web	2-5	0.055	334 lbs		2-4	0.937	479 lbs	(-1,175 lbs)

Notes

- 1) Unless noted otherwise, do not cut or alter any truss member or plate without prior approval from a Professional Engineer.
- 2) The fabrication tolerance for this roof truss is 20% (Cq = 0.80).
- 3) Brace bottom chord with approved sheathing or purlins per Bracing Summary.
- 4) A creep factor of 2.00 has been applied for this truss analysis.
- 5) The "SYP" label shown in the "Material Summary" above indicates the new SPIB design values effective June 1, 2013 were used.
- 6) Listed wind uplift reactions based on MWFRS & C&C loading.

WARNING: Verify all design parameters and follow all notes on this drawing and in the Eagle Metal Design Notes. This design is for an individual building component (a truss), not a truss system, and is based only on parameters shown and provided by the Building Designer. The applicability of the design parameters must be verified by the Building Designer and should properly incorporate this design into the overall building design before use. Bracing shown is only to prevent buckling of individual truss web and/or chord members. Additional temporary and permanent bracing is always required to prevent collapse and provide stability. Design valid only when Eagle Metal connectors are used. A seal on this drawing indicates acceptance of professional engineering responsibility solely for the truss component design shown.

TrueBuild® Truss Software v5.8.14
Eagle Metal Products

Quality Line Truss Co., LLC

34593 S 4350 RD
Address 2
Adair, OK 74330

Truss:T06

Job: LOT 7_H BUILDING_REFRAMING

Date: 12/03/25 20:18:09

Page: 1 of 1

SPAN 20-0-0	PITCH 5/12	QTY 5	OHL 1-4-0	OHR 1-4-0	CANT L 0-0-0	CANT R 0-0-0	PLY(S) 1	SPACING 24 in	WGT/PLY 103 lbs
----------------	---------------	----------	--------------	--------------	-----------------	-----------------	-------------	------------------	--------------------

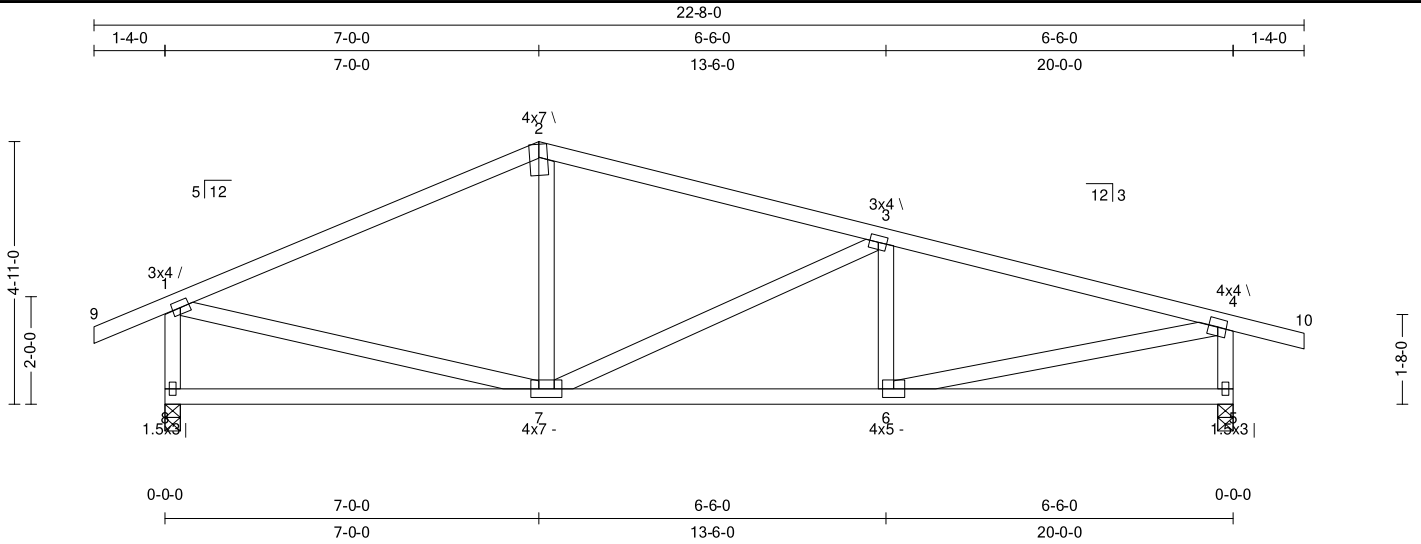

All plates shown to be Eagle 20 unless otherwise noted.

Loading (psf)	General	CSI	Deflection	L/	(loc)	Allowed
TCLL: 20	Bldg Code: IBC 2018/	TC: 0.61 (1-2)	Vert TL: 0.18 in	L/999	(7-8)	L/240
TCDL: 10	TPI 1-2014	BC: 0.59 (6-7)	Vert LL: 0.08 in	L/999	(7-8)	L/360
BCLL: 0	Rep Mbr: Yes	Web: 0.40 (3-7)	Horz TL: 0.01 in		5	
BCDL: 10	Lumber D.O.L.: 115 %					

Reaction

12/04/2025

JT	Brg Combo	Brg Width	Rqd Brg Width	Max React	Max Grav Uplift	Max MWFRS Uplift	Max C&C Uplift	Max Uplift	Max Horiz
8	1	3.5 in	1.50 in	1,080 lbs		-90 lbs	-352 lbs	-352 lbs	-64 lbs
5	1	3.5 in	1.50 in	1,080 lbs		-89 lbs	-345 lbs	-345 lbs	

Material

TC: SYP#1 2 x 4
BC: SYP#1 2 x 4
Web: SYP#1 2 x 4

Bracing

TC: Sheathed or Purlins at 4-7-0, Purlin design by Others.
BC: Sheathed or Purlins at 10-0-0, Purlin design by Others.

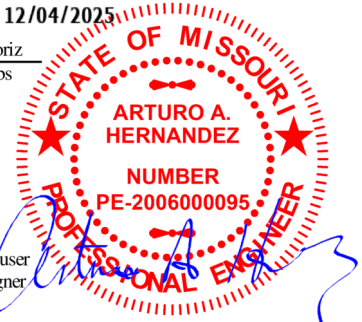

Loads

- 1) This truss has been designed for the effects of balanced (14 psf) and unbalanced sloped roof snow loads in accordance with ASCE7 - 16 with the following user defined input: 20 psf GSL, Terrain C, Exposure (Ce = 1.0), Thermal (Ct = 1.00), DOL = 1.15. If the roof configuration differs from hip/gable, Building Designer shall verify snow loads.
- 2) This truss has been designed to account for the effects of ice dams forming at the eaves.
- 3) This truss has been designed for the effects of wind loads in accordance with ASCE7 - 16 with the following user defined input: 115 mph (Factored), Exposure C, Enclosed, Gable/Hip, Risk Category II, Overall Bldg Dims 25 ft x 60 ft, h = 15 ft, End Zone Truss, Both end webs considered. DOL = 1.60
- 4) Concurrent minimum storage attic loading has been applied in accordance with IBC 1607.1

Member Forces

Table indicates: Member ID, max CSI, max tension force, (max compression force). Only forces greater than 300lbs are shown in this table.

TC	1-2	0.607	372 lbs	(-1,195 lbs)	3-4	0.380	437 lbs	(-1,596 lbs)			
	2-3	0.409	382 lbs	(-1,125 lbs)							
BC	6-7	0.590	1,509 lbs								
Web	1-8	0.105	387 lbs	(-960 lbs)	3-7	0.403	(-543 lbs)	4-5	0.102	377 lbs	(-968 lbs)
	1-7	0.178	1,072 lbs		4-6	0.256	1,546 lbs				

Notes

- 1) Unless noted otherwise, do not cut or alter any truss member or plate without prior approval from a Professional Engineer.
- 2) The fabrication tolerance for this roof truss is 20 % (Cq = 0.80).
- 3) Brace bottom chord with approved sheathing or purlins per Bracing Summary.
- 4) A creep factor of 2.00 has been applied for this truss analysis.
- 5) The "SYP" label shown in the "Material Summary" above indicates the new SPIB design values effective June 1, 2013 were used.
- 6) Listed wind uplift reactions based on MWFRS & C&C loading.

WARNING: Verify all design parameters and follow all notes on this drawing and in the Eagle Metal Design Notes. This design is for an individual building component (a truss), not a truss system, and is based only on parameters shown and provided by the Building Designer. The applicability of the design parameters must be verified by the Building Designer and should properly incorporate this design into the overall building design before use. Bracing shown is only to prevent buckling of individual truss web and/or chord members. Additional temporary and permanent bracing is always required to prevent collapse and provide stability. Design valid only when Eagle Metal connectors are used. A seal on this drawing indicates acceptance of professional engineering responsibility solely for the truss component design shown.

TrueBuild® Truss Software v5.8.14
Eagle Metal Products

POINT LOAD/P	8dx2.5" BOX				0.120 Ø GUN (3" MIN)				10, 12d BOX or 8d COMMON or 0.131Ø GUN (3" MIN)				16d BOX				12d COMMON OR 20d BOX				16d COMMON			
	SP		SPF		SP		SPF		SP		SPF		SP		SPF		SP		SPF		SP		SPF	
	2-PLY	3-PLY	2-PLY	3-PLY	2-PLY	3-PLY	2-PLY	3-PLY	2-PLY	3-PLY	2-PLY	3-PLY	2-PLY	3-PLY	2-PLY	3-PLY	2-PLY	3-PLY	2-PLY	3-PLY	2-PLY	3-PLY	2-PLY	3-PLY
500	4	5	5	6	3	4	4	5	3	4	3	4	2	3	3	4	2	3	3	3	2	2	2	3
1,000	7	10	9	12	6	7	7	10	5	7	7	9	4	6	6	9	4	5	5	7	3	4	4	6
1,500	11	14	14	19	8	11	11	14	8	11	10	14	7	9	10	13	6	8	8	10	5	6	6	8
2,000	14	19	19	25	11	15	14	19	11	14	14	18	9	12	13	17	8	10	10	13	6	9	8	11
2,500	18	24	23	31	14	19	18	24	13	18	17	23	11	15	16	22	10	13	13	17	8	11	10	14
3,000	21	29	28	37	17	22	22	29	16	21	21	28	13	18	19	26	12	16	15	20	10	13	13	17
3,500	25	33	32	43	20	26	25	34	19	25	24	32	15	21	23	30	14	18	18	23	11	15	15	19
4,000	29	38	37	49	22	30	29	39	21	29	28	37	18	24	26	34	16	21	20	27	13	17	17	22
4,500	32	43	42	56	25	34	33	43	24	32	31	42	20	27	29	39	18	23	23	30	15	19	19	25
5,000	36	48	46	62	28	37	36	48	27	36	35	46	22	29	32	43	20	26	25	33	16	22	21	28
5,500	39	52	51	68	31	41	40	53	29	39	38	51	24	32	36	47	21	29	28	37	18	24	23	31
6,000	43	57	56	74	34	45	43	58	32	43	42	55	27	35	39	52	23	31	30	40	19	26	25	33
6,500	46	62	60	80	37	49	47	63	35	46	45	60	29	38	42	56	25	34	33	43	21	28	27	36
7,000	50	67	65	86	39	52	51	68	38	50	49	65	31	41	45	60	27	36	35	47	23	30	29	39
7,500	54	71	69	93	42	56	54	72	40	54	52	69	33	44	48	65	29	39	38	50	24	32	31	42
8,000	57	76	74	99	45	60	58	77	43	57	55	74	35	47	52	69	31	42	40	53	26	35	33	44
8,500	61	81	79	105	48	64	62	82	46	61	59	79	38	50	55	73	33	44	43	57	28	37	35	47
9,000	64	86	83	111	51	67	65	87	48	64	62	83	40	53	58	77	35	47	45	60	29	39	38	50
9,500	68	90	88	117	53	71	69	92	51	68	66	88	42	56	61	82	37	49	48	63	31	41	40	53
10,000	71	95	93	123	56	75	72	97	54	72	69	92	44	59	65	86	39	52	50	67	32	43	41	56
p =	P/70/2	2P/70/3	P/54/2	2P/54/3	P/89/2	2P/89/3	P/69/2	2P/69/3	P/93/2	2P/93/3	P/72/2	2P/72/3	P/113/2	2P/113/3	P/77/2	2P/77/3	P/128/2	2P/128/3	P/100/2	2P/100/3	P/154/2	2P/154/3	P/120/2	2P/120/3

(DETAILS ARE NOT TO SCALE)

NAIL TYPE	NAIL CHARACTERISTICS		
	EDGE	MIN SPACING	END
8d BOX (0.113Ø"x2.5")	3/4	1 3/8	1 3/4
10d BOX (0.128Ø"x3")	7/8	1 5/8	2
12d BOX (0.128Ø"x3.25")	7/8	1 5/8	2
16d BOX (0.135Ø"x3.5")	7/8	1 5/8	2 1/8
20d BOX (0.148Ø"x4")	1	1 7/8	2 1/4
8d COMMON (0.131Ø"x2.5")	7/8	1 5/8	2
10d COMMON (0.148Ø"x3.0")	1	1 7/8	2 1/4
12d COMMON (0.148Ø"x3.25")	1	1 7/8	2 1/4
16d COMMON (0.162Ø"x3.5")	1	2	2 1/2
0.120"x2.5" GUN	3/4	1 1/2	1 7/8
0.131"x2.5" GUN	7/8	1 5/8	2
0.120"x3.0" GUN	3/4	1 1/2	1 7/8
0.131"x3.0" GUN	7/8	1 5/8	2

GENERAL NOTES

- EDGE DISTANCE AND SPACING BETWEEN STAGGERED ROWS IS 6d; NAILS MAY NOT BE WITHIN EDGE LINE.
- SPACING OF NAILS IN A ROW IS 12d.
- END DISTANCE IS 15d; IN ADDITION TO NOTE #2, NAILS MAY NOT BE WITHIN END DISTANCES FROM END OF THE BOARD.
- WHEN 3-PLIES ARE USED, INSTALL NAILS INTO 2-PLIES WITH 2x THE NAIL SPACING; THEN ADD THIRD PLY WITH 2x NAIL SPACING.
- RECOMMEND 1 ROW FOR 2x4, 2 ROWS FOR 2x6 & 2x8, 3 ROWS FOR 2x10 & 2x12.
- IF TRUSSES ARE SUPPORTED ON BOTH SIDES, DOUBLE THE SPACING AND ALTERNATE HEADS OF NAILS ON OPPOSING SIDES.

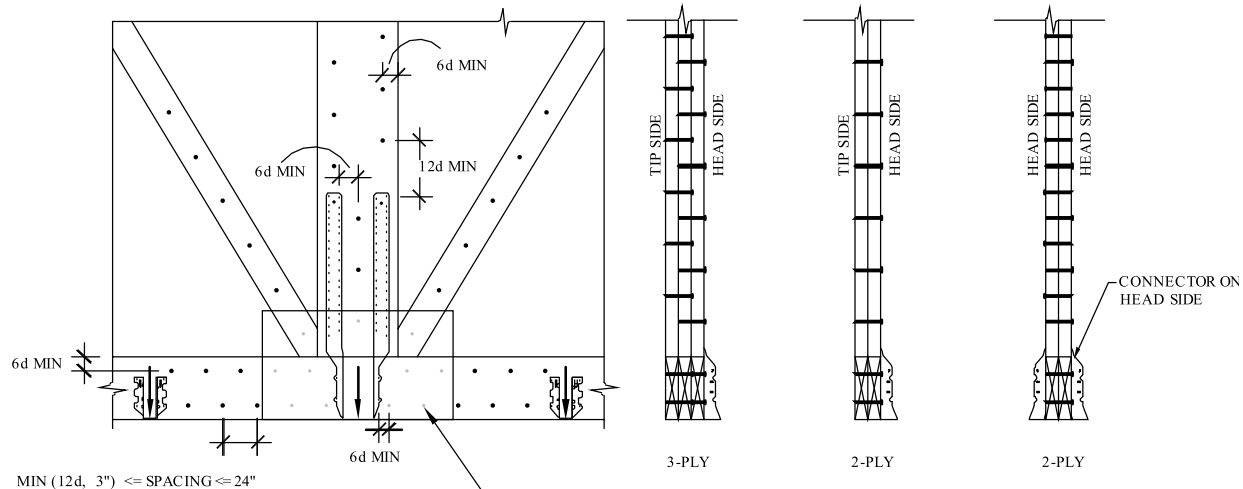

AVOID SCREWING THROUGH PLATES, OR PRE-DRILL & VERIFY PLATE HAS RESERVE CAPACITY

DRAWING NUMBER
DR-1

REV: 2.1
ENG: MDV
CAD: RC
DATE: 03/16/18

MULTI-PLY TRUSS GIRDER PLY CONNECTOR FOR ISOLATED POINT LOADS (NAILS)



1253550 0024/0024